

DL - DL W/C

SUBMERSIBLE SEWAGE PUMPS (DL) WITH CUTTER (DL W/C)

in cast iron

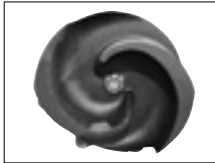

**OPEN
DOUBLE CHANNEL
IMPELLER**



**OPEN SINGLE-CHANNEL
WITH CUTTER
IMPELLER**



**NON-CLOG
SEMI-OPEN
IMPELLER**

PUMP IDENTIFICATION CODE

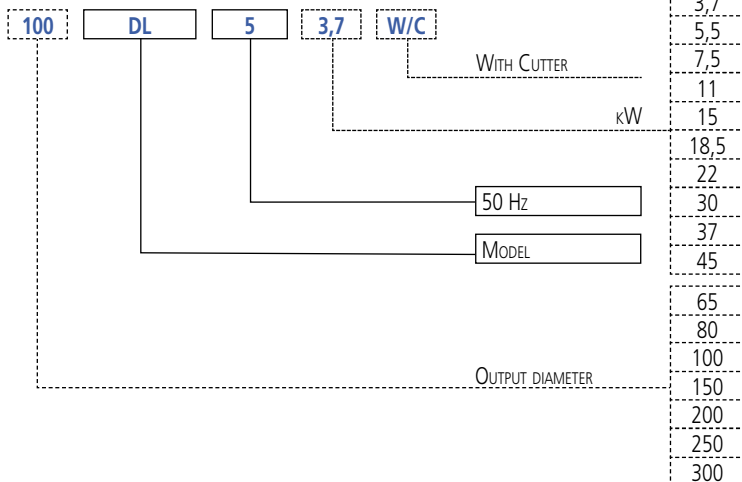

Submersible sewage pumps (DL) with cutter (DL W/C) in cast iron

APPLICATIONS

- Ideal for waste water applications containing soft or fibrous solids
- Industrial waste water drainage

TECHNICAL DETAILS

- Non-Clog single-channel, double-channel Vitex open impeller prevents clogging by fibrous matter
- Range of models from 65 to 300 mm discharge size and power up to 45 kW (DL)

TECHNICAL DATA

- Maximum temperature of the liquid: 40°C
- Max solids size for passage: 46 mm (65DL, 65DL W/C)
46 mm (80DL, all DLC, 80 DL W/C)
57 mm (100DL, 100DLB, 100DL W/C,
100DLB W/C)
68 mm (150DL up to 22kW)
73 mm (200DL up to 22kW)
76 mm (all models 30÷45 kW)
79 mm (250DL up to 22kW)
88 mm (300DL up to 22kW)
- Max fibers length: 195 mm (65DL, 65DL W/C)
240 mm (80DL, all DLC, 80DL W/C)
300 mm (100DL, 100DLB, 100DL W/C)
400 mm (150DL from 5.5 kW up to 45 kW)
500 mm (200DL up to 45 kW)
500 mm (all models 30÷44 kW)
550 mm (250DL up to 45 kW)
600 mm (300DL up to 45 kW)
- 4 poles motor
- Insulation class F
- Degree protection IP68
- 380-415±10%, 50Hz (1,5÷7,5kW) (DL and DL W/C) threephase voltage
400-415±10%, 50Hz (Δ connection 11÷22 kW) (DL) threephase voltage
380-415±10%, 50Hz (Δ connection 30÷45 kW) (DL) threephase voltage
- Flanges: DN65, DN80, DN100, DN150, DN200, DN250, DN300 (DL)
DN65, DN80, DN100 (DL W/C)
- Power up to 45 kW (DL)
up to 7.5 kW (DL W/C)

MATERIALS

- Pump body, impeller (DL), elbow in cast iron
- Shaft in AISI 403
- Mechanical seal: SiC/SiC/NBR (pump side)
Carbon/Ceramic/NBR (motor side)

ACCESSORIES (ON REQUEST)

- see from page 134



DL - DL W/C

SUBMERSIBLE SEWAGE PUMPS (DL) WITH CUTTER (DL W/C)
in cast iron

PERFORMANCE CHART 65-80DL

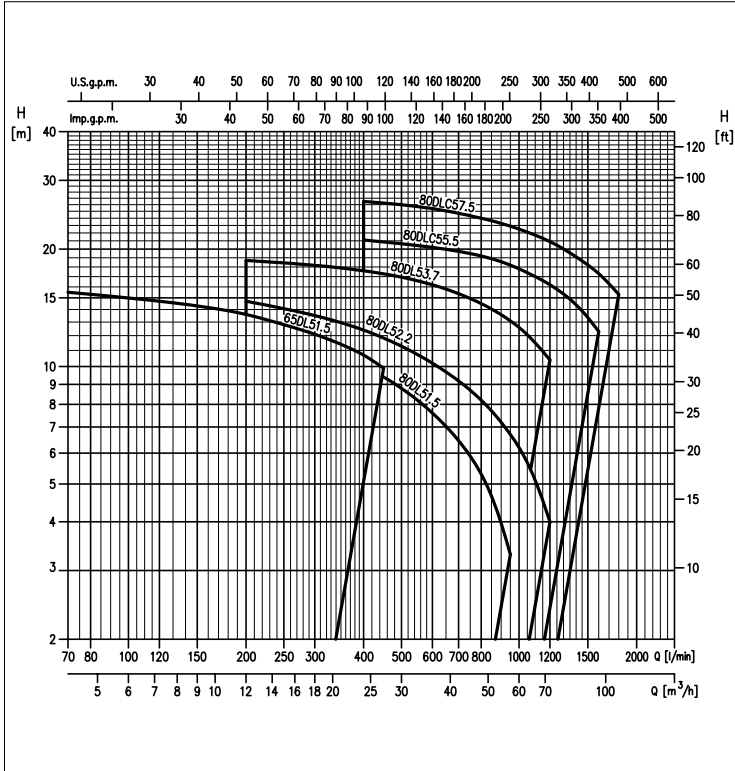

100DL

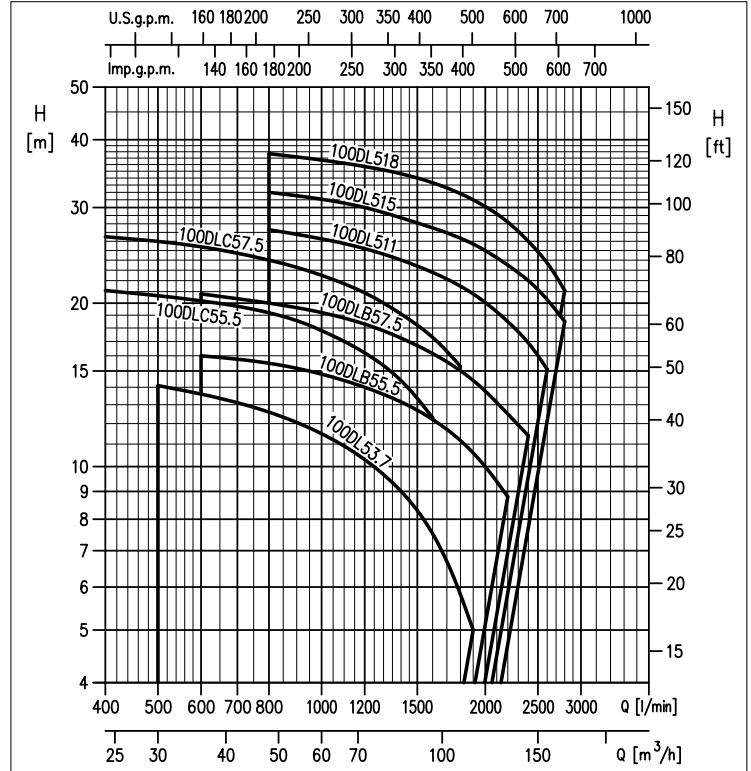

150DL

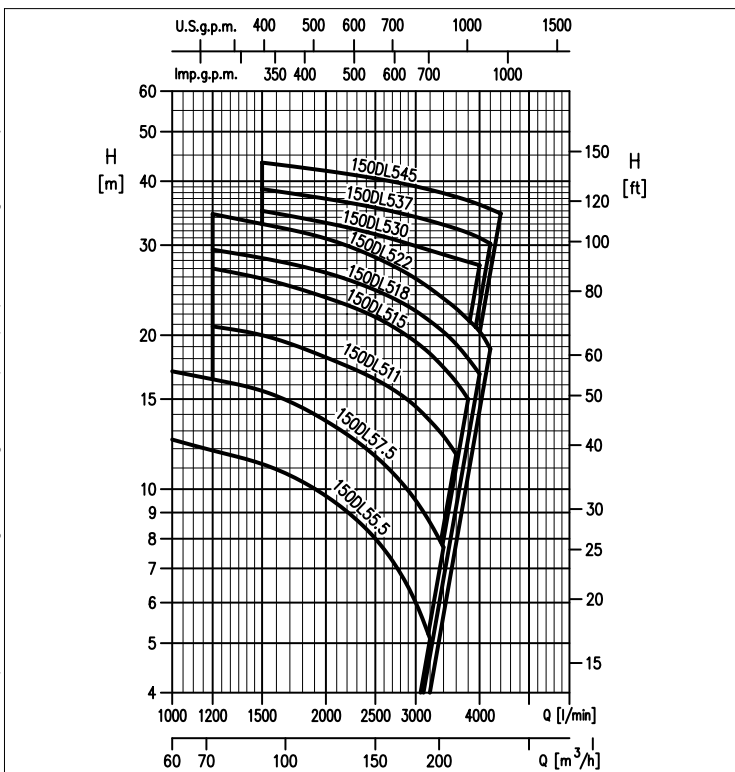

200DL

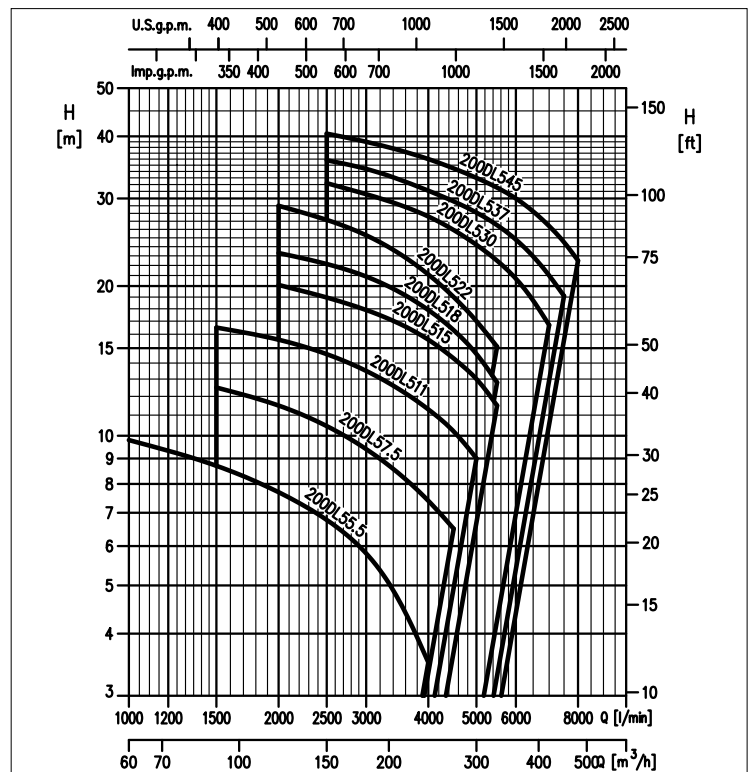

The contents of this publication must not be regarded as binding. EBARA Pumps Europe S.p.A. reserves the right to effect any modification it deems necessary, without prior notice.



DL - DL W/C

SUBMERSIBLE SEWAGE PUMPS (DL) WITH CUTTER (DL W/C)
in cast iron

250DL

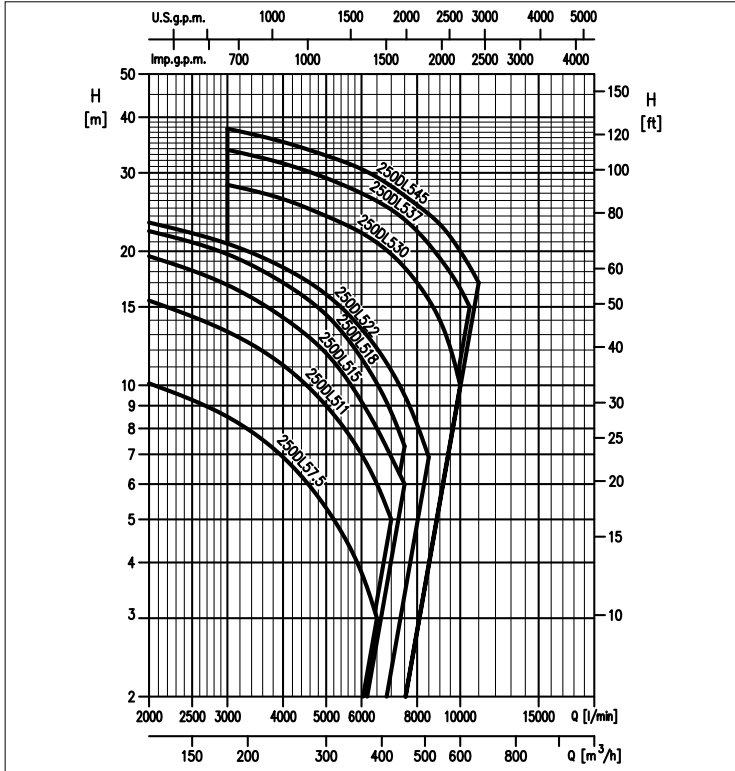

300DL

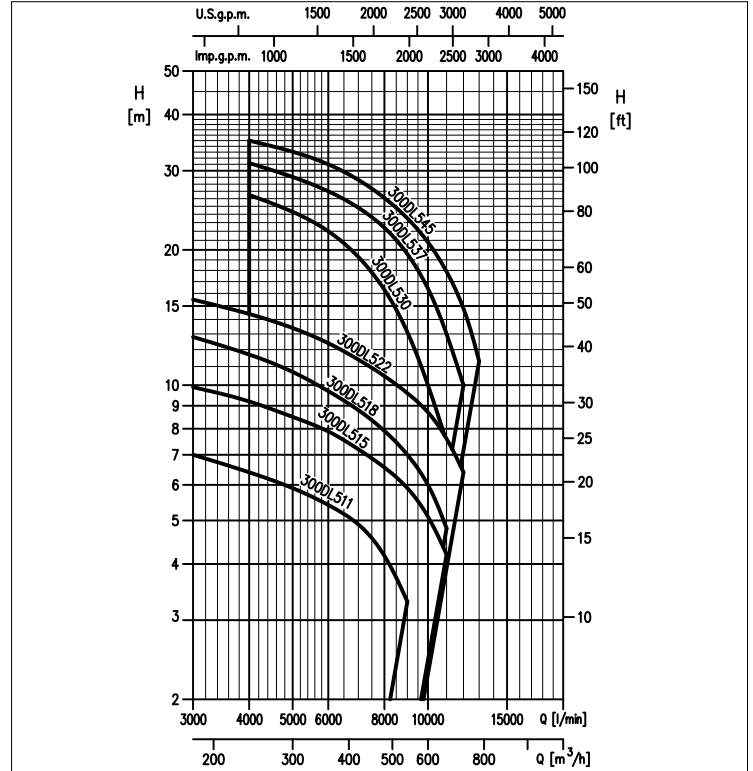

The contents of this publication must not be regarded as binding. EBARA Pumps Europe S.p.A. reserves the right to effect any modification it deems necessary, without prior notice.

DL - DL W/C

SUBMERSIBLE SEWAGE PUMPS (DL) WITH CUTTER (DL W/C)

in cast iron

PERFORMANCE TABLE 65-80DL

Model	P ₂		Q=Flow rate													
	[HP]	[kW]	l/min	70	150	200	400	450	600	800	950	1000	1200	1400	1600	1800
			m ³ /h	4	9	12	24	27	36	48	57	60	72	84	96	108
H=Head [m]																
65DL51.5	2	1,5	15,5	14,3	13,6	10,7	9,9	-	-	-	-	-	-	-	-	-
80DL51.5	2	1,5	-	-	12,2	10,0	9,4	7,6	5,3	3,3	-	-	-	-	-	-
80DL52.2	3	2,2	-	-	14,7	12,4	11,8	10,2	8,2	6,7	6,2	4,0	-	-	-	-
80DL53.7	5	3,7	-	-	18,7	17,6	17,3	16,2	14,5	13,1	12,6	10,4	-	-	-	-
80DLC55.5	7,5	5,5	-	-	-	21,1	20,9	20,2	19,2	18,2	17,8	16,2	14,4	12,3	-	-
80DLC57.5	10	7,5	-	-	-	26,5	26,3	25,4	24,0	22,9	22,5	20,9	19,1	17,3	15,3	-

PERFORMANCE TABLE 100DL

Model	P ₂		Q=Flow rate													
	[HP]	[kW]	l/min	400	500	600	800	1200	1500	1600	1800	1900	2200	2400	2600	2800
			m ³ /h	24	30	36	48	72	90	96	108	114	132	144	156	168
H=Head [m]																
100DLC55.5	7,5	5,5	21,1	20,7	20,2	19,2	16,2	13,3	12,3	-	-	-	-	-	-	-
100DLC57.5	10	7,5	26,5	25,9	25,4	24,0	20,9	18,3	17,3	15,3	-	-	-	-	-	-
100DL53.7	5	3,7	-	14,1	13,6	12,6	10,3	8,3	7,5	5,9	5,0	-	-	-	-	-
100DLB55.5	7,5	5,5	-	-	16,0	15,5	14,0	12,7	12,2	11,1	10,6	8,8	-	-	-	-
100DLB57.5	10	7,5	-	-	20,8	20,0	18,3	16,7	16,1	15,1	15,0	12,5	11,4	-	-	-
100DL511	15	11	-	-	-	27,3	25,2	23,4	22,8	21,5	20,8	18,5	16,9	15,1	-	-
100DL515	20	15	-	-	-	32,0	30,0	28,1	27,6	26,4	25,7	23,5	22,0	20,3	18,5	-
100DL518.5	25	18,5	-	-	-	37,7	35,7	34,0	33,4	31,9	31,0	28,2	26,0	23,7	21,1	-

PERFORMANCE TABLE 150DL

Model	P ₂		Q=Flow rate														
	[HP]	[kW]	l/min	1000	1200	1500	2000	2500	3000	3200	3400	3500	3600	3800	4000	4200	4400
			m ³ /h	60	72	90	120	150	180	192	204	210	216	228	240	252	264
H=Head [m]																	
150DL55.5	7,5	5,5	12,5	11,9	11,2	9,7	8,0	6,0	5,1	-	-	-	-	-	-	-	-
150DL57.5	10	7,5	17,0	16,4	15,2	13,6	11,6	9,5	8,6	7,7	-	-	-	-	-	-	-
150DL511	15	11	-	20,8	20,0	18,1	16,4	14,5	13,6	12,7	12,2	11,7	-	-	-	-	-
150DL515	20	15	-	27,0	25,8	23,7	21,7	19,4	18,4	17,3	16,8	16,2	15,0	-	-	-	-
150DL518.5	25	18,5	-	29,4	28,3	26,5	24,5	22,3	21,3	20,3	19,8	19,2	18,0	16,8	-	-	-
150DL522	30	22	-	34,5	33,0	30,9	28,4	25,8	24,7	23,6	23,0	22,4	21,2	20,5	18,8	-	-
150DL530	40	30	-	-	35,0	33,2	31,5	29,9	29,3	28,8	28,5	28,3	27,8	27,4	-	-	-
150DL537	50	37	-	-	38,6	37,0	35,5	34,1	33,5	32,9	32,6	32,3	31,7	31,0	30,2	-	-
150DL545	60	45	-	-	43,5	42,0	40,5	39,1	38,5	37,9	37,6	37,3	36,7	36,0	35,3	34,6	-

PERFORMANCE TABLE 200DL

Model	P ₂		Q=Flow rate													
	[HP]	[kW]	l/min	1000	1500	2000	2500	3000	4000	4500	5000	5500	6000	7000	7500	8000
			m ³ /h	60	90	120	150	180	240	270	300	330	360	420	450	480
H=Head [m]																
200DL55.5	7,5	5,5	9,8	8,7	7,7	6,8	5,8	3,5	-	-	-	-	-	-	-	-
200DL57.5	10	7,5	-	12,5	11,5	10,5	9,4	7,4	6,5	-	-	-	-	-	-	-
200DL511	15	11	-	16,5	15,6	14,6	13,5	11,3	10,2	9,0	-	-	-	-	-	-
200DL515	20	15	-	-	20,1	19,0	17,9	15,6	14,3	13,0	11,5	-	-	-	-	-
200DL518.5	25	18,5	-	-	23,3	22,2	20,9	17,9	16,3	14,6	12,8	-	-	-	-	-
200DL522	30	22	-	-	29,0	27,2	25,3	21,1	19,0	17,0	15,1	-	-	-	-	-
200DL530	40	30	-	-	-	32,2	30,6	27,6	25,9	24,2	22,5	20,7	16,7	-	-	-
200DL537	50	37	-	-	-	35,8	34,4	31,1	29,6	28,1	26,5	24,8	21,0	19,1	-	-
200DL545	60	45	-	-	-	40,5	39,0	36,0	34,5	33,0	31,5	30,0	26,4	24,5	22,5	-

The contents of this publication must not be regarded as binding. EBARA Pumps Europe S.p.A. reserves the right to effect any modification it deems necessary, without prior notice.

DL - DL W/C

SUBMERSIBLE SEWAGE PUMPS (DL) WITH CUTTER (DL W/C)

in cast iron

PERFORMANCE TABLE 250DL

Model	P ₂		Q=Flow rate														
	[HP]	[kW]	l/min	2000	3000	4000	5000	6000	6500	7000	7500	8000	8500	9000	10000	10500	11000
			m ³ /h	120	180	240	300	360	390	420	450	480	510	540	600	630	660
H=Head [m]																	
250DL57.5	10	7,5	10,1	8,5	6,9	5,3	3,8	3,0	-	-	-	-	-	-	-	-	-
250DL511	15	11	15,5	13,2	11,1	9,0	7,0	6,0	5,0	-	-	-	-	-	-	-	-
250DL515	20	15	19,5	16,8	14,2	11,8	9,2	8,0	6,9	6,0	-	-	-	-	-	-	-
250DL518.5	25	18,5	22,2	19,7	17,0	14,4	11,5	10,1	8,7	7,3	-	-	-	-	-	-	-
250DL522	30	22	23,2	20,8	18,4	16,0	13,4	12,1	10,8	9,5	8,2	6,9	-	-	-	-	-
250DL530	40	30	-	28,2	26,2	24,0	22,0	20,9	19,7	18,4	17,0	15,6	14,0	10,0	-	-	-
250DL537	50	37	-	33,8	31,5	29,2	27,0	25,9	24,8	23,5	22,2	20,8	19,3	16,5	15,0	-	-
250DL545	60	45	-	37,7	35,2	32,8	30,6	29,3	28,0	26,7	25,4	24,2	23,0	20,0	18,5	17,0	-

PERFORMANCE TABLE 300DL

Model	P ₂		Q=Flow rate											
	[HP]	[kW]	l/min	3000	4000	5000	6000	7000	8000	9000	10000	11000	12000	13000
			m ³ /h	180	240	300	360	420	480	540	600	660	720	780
H=Head [m]														
300DL511	15	11	7,0	6,4	5,9	5,5	4,9	4,2	3,3	-	-	-	-	-
300DL515	20	15	9,9	9,2	8,5	8,0	7,2	6,6	5,9	5,1	4,2	-	-	-
300DL518.5	25	18,5	12,8	11,7	10,7	9,7	8,8	7,9	7,0	6,0	4,8	-	-	-
300DL522	30	22	15,5	14,4	13,4	12,4	11,4	10,5	9,6	8,7	7,6	6,4	-	-
300DL530	40	30	-	26,5	24,4	22,0	19,3	16,3	13,1	10,0	7,5	-	-	-
300DL537	50	37	-	31,2	29,2	27,0	24,8	22,4	19,6	16,4	13,0	10,0	-	-
300DL545	60	45	-	35,0	33,1	31,0	28,6	26,1	23,5	20,8	17,9	14,8	11,3	-

The contents of this publication must not be regarded as binding. EBARA Pumps Europe S.p.A. reserves the right to effect any modification it deems necessary, without prior notice.

DL - DL W/C

SUBMERSIBLE SEWAGE PUMPS (DL) WITH CUTTER (DL W/C) in cast iron

PERFORMANCE CHART DL W/C (With CUTTER)

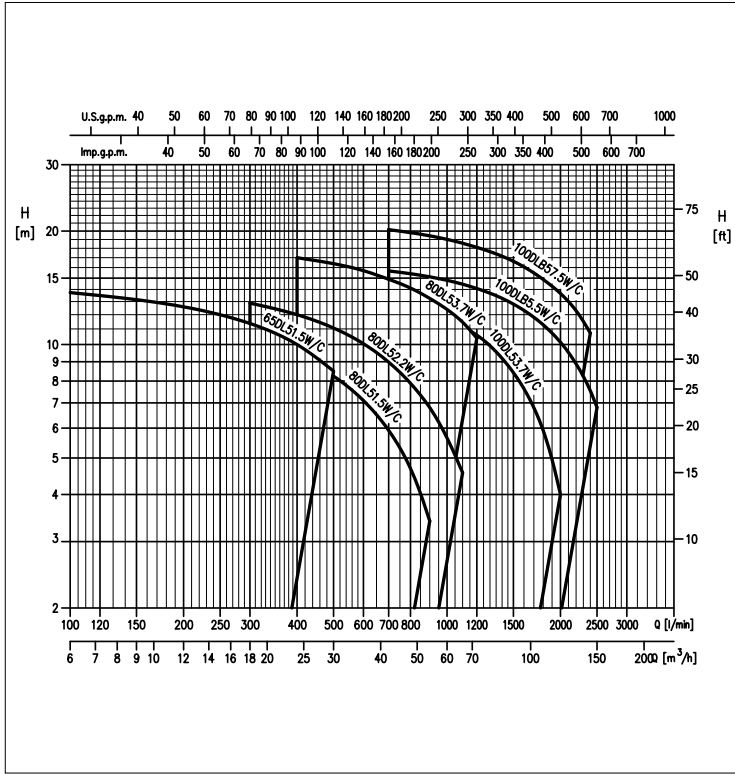

PERFORMANCE TABLE 65-80-100 DL W/C (With CUTTER)

Model	P ₂		Q=Flow rate																
			l/min	100	250	300	400	500	700	900	1000	1100	1200	1400	1600	2000	2400	2500	
	[HP]	[kW]	m ³ /h	6	15	18	24	30	42	54	60	66	72	84	96	120	144	150	
			H=Head [m]																
65DL51.5W/C	2	1,5	13,7	12,0	11,4	10,0	8,5	-	-	-	-	-	-	-	-	-	-	-	
80DL51.5W/C	2	1,5	-	10,7	10,3	9,3	8,2	5,9	3,4	-	-	-	-	-	-	-	-	-	
80DL52.2W/C	3	2,2	-	-	12,9	12,0	11,1	9,0	6,8	5,7	4,6	-	-	-	-	-	-	-	
80DL53.7W/C	5	3,7	-	-	-	17,0	16,4	14,9	13,4	12,6	11,6	10,4	-	-	-	-	-	-	
100DL53.7W/C	5	3,7	-	-	-	-	14,1	13,1	12,2	11,7	11,2	10,6	9,2	7,6	4,0	-	-	-	
100DLB55.5W/C	7,5	5,5	-	-	-	-	-	15,7	15,1	14,8	14,5	14,1	13,3	12,3	10,1	7,5	6,8	-	
100DLB57.5W/C	10	7,5	-	-	-	-	-	20,2	19,4	19,0	18,6	18,1	17,2	16,1	13,7	10,7	-	-	

The contents of this publication must not be regarded as binding. EBARA Pumps Europe S.p.A. reserves the right to effect any modification it deems necessary, without prior notice.



DL - DL W/C

SUBMERSIBLE SEWAGE PUMPS (DL) WITH CUTTER (DL W/C) in cast iron

65DL51.5 (1.5 kW) range PERFORMANCE CURVES

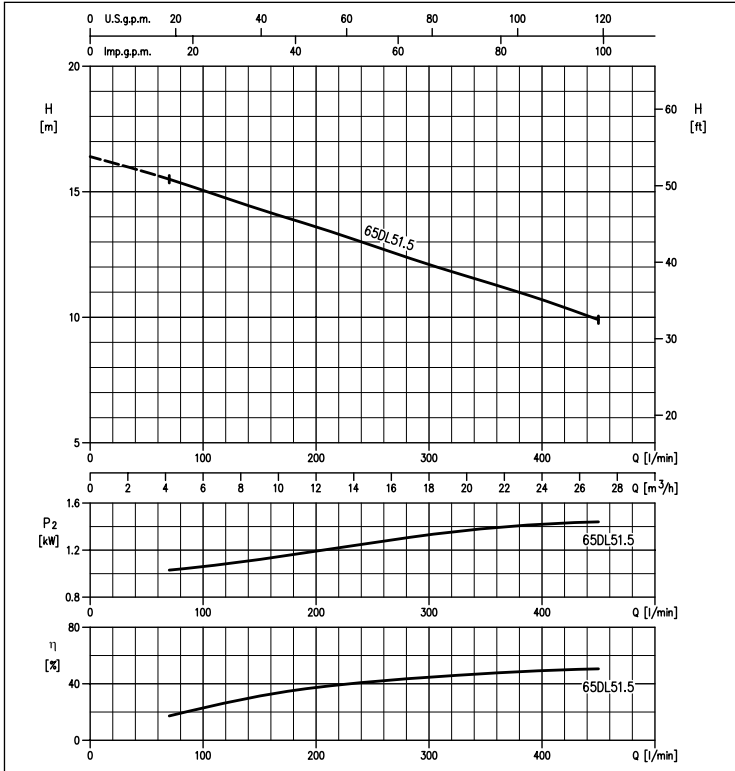

80DL51.5 (1.5 kW) range PERFORMANCE CURVES
80DL53.7 (3.7 kW) range 8080DL52.2 (2.2 kW) range
80DLC57.5 (7.5 kW) range 80DLC55.5 (5.5 kW)

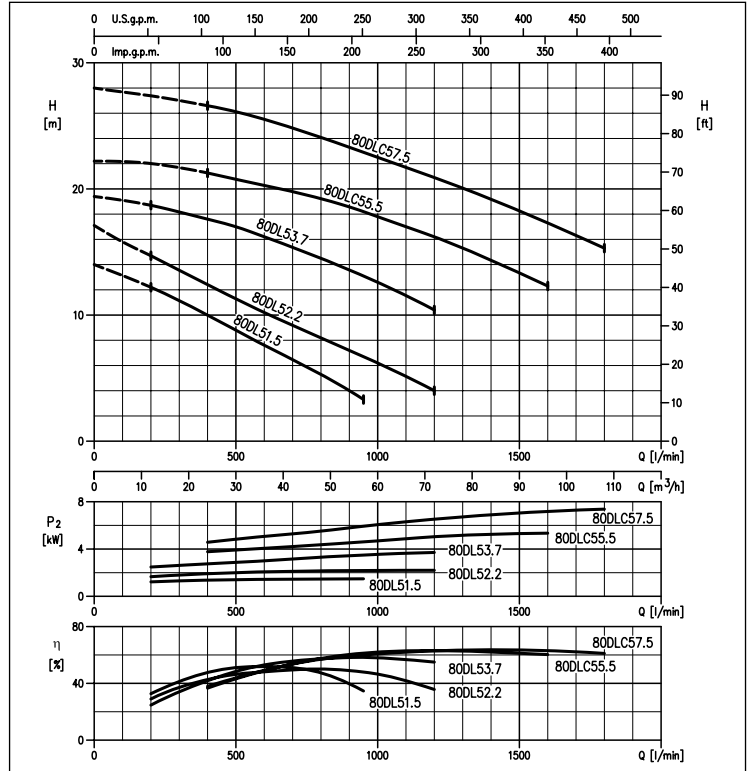

100DL53.7 (3.7 kW)
100DLB57.5 (7.5 kW)
100DL515 (15 kW)

100DLB55.5 (5.5 kW) PERFORMANCE CURVES
100DL511 (11 kW)
100DL518.5 (18.5 kW)

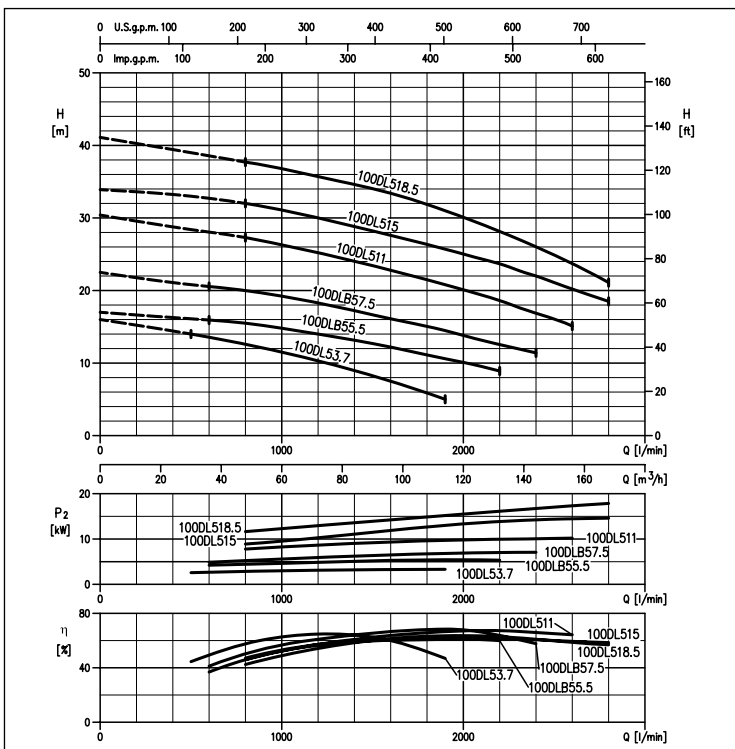

100DLC55.5 (5.5 kW) PERFORMANCE CURVES
100DLC57.5 (7.5 kW)

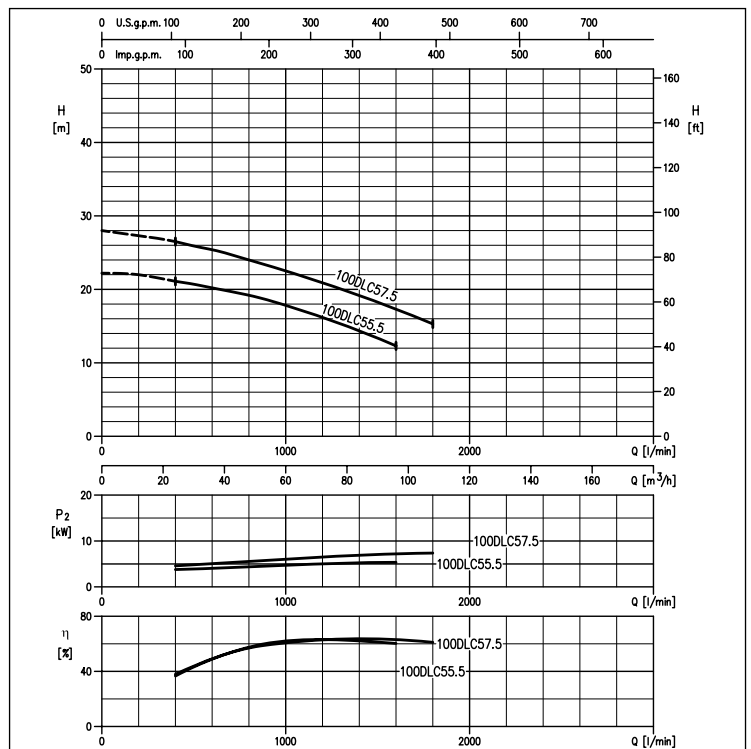



DL - DL W/C

SUBMERSIBLE SEWAGE PUMPS (DL) WITH CUTTER (DL W/C) in cast iron

PERFORMANCE CURVES 150DL55.5 (5.5 kW) 150DL57.5 (7.5 kW)
150DL511 (11 kW) 150DL515 (15 kW)
150DL518.5 (18.5 kW) 150DL522 (22 kW)

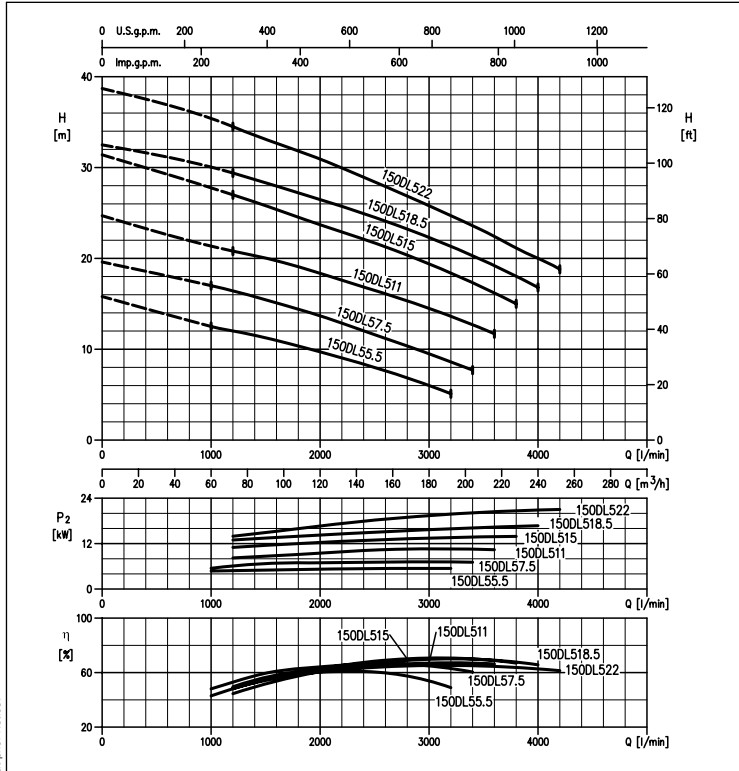

PERFORMANCE CURVES 150DL530 (30 kW)
150DL537 (37 kW)
150DL545 (45 kW)

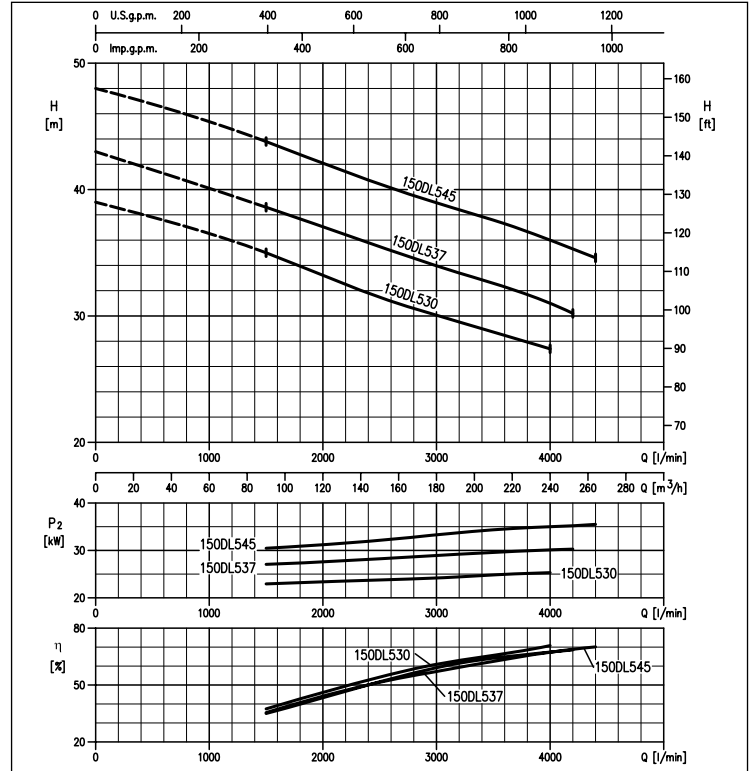

PERFORMANCE CURVES 200DL55.5 (5.5 kW) 200DL57.5 (7.5 kW)
200DL511 (11 kW) 200DL515 (15 kW)
200DL518.5 (18.5 kW) 200DL522 (22 kW)

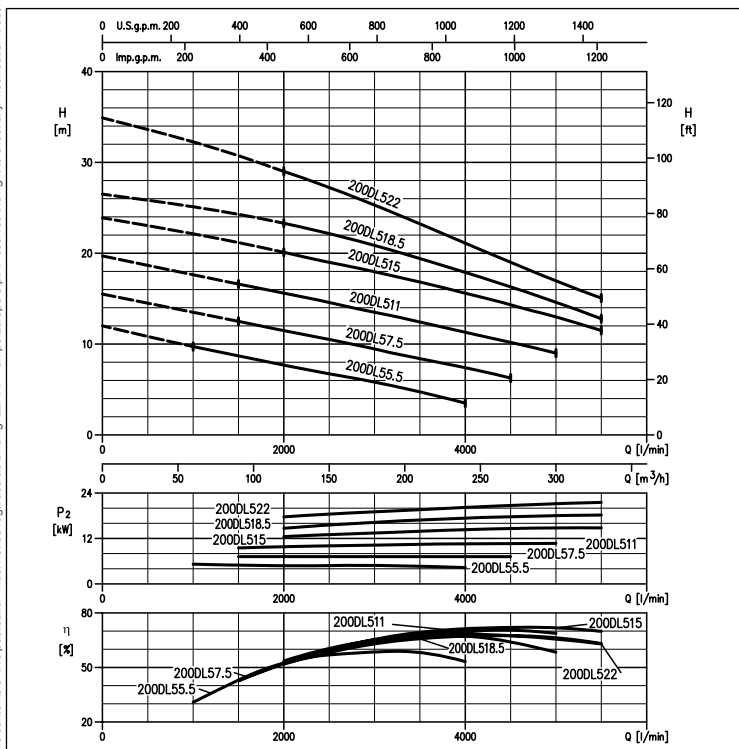

PERFORMANCE CURVES 200DL530 (30 kW)
200DL537 (37 kW)
200DL545 (45 kW)

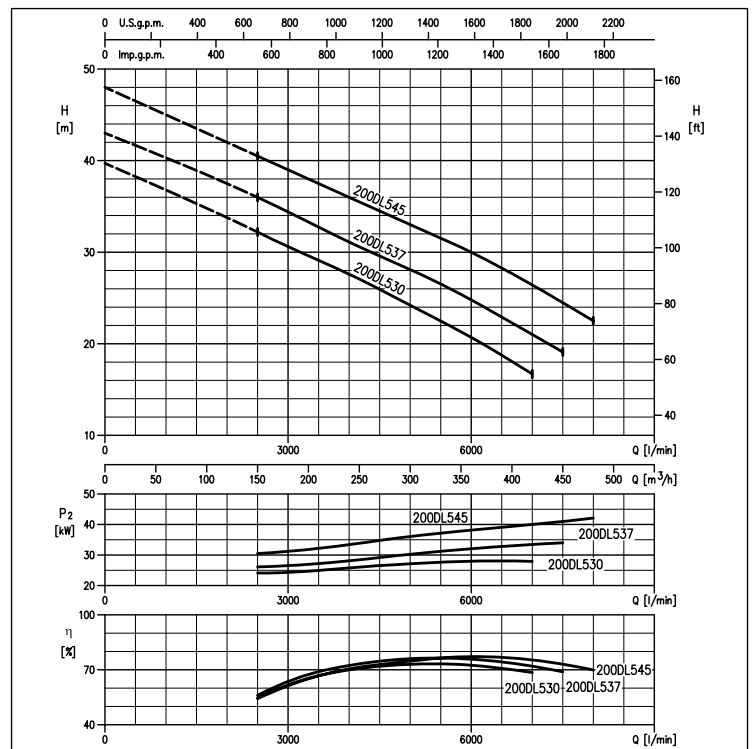

The contents of this publication must not be regarded as binding. EBARA Pumps Europe S.p.A. reserves the right to effect any modification it deems necessary, without prior notice.



DL - DL W/C

SUBMERSIBLE SEWAGE PUMPS (DL) WITH CUTTER (DL W/C)
in cast iron

PERFORMANCE CURVES 250DL57.5 (7.5 kW) 250DL 511 (11 kW) 250DL515 (15 kW) 250DL522 (22 kW) 250DL 518.5 (18.5 kW)

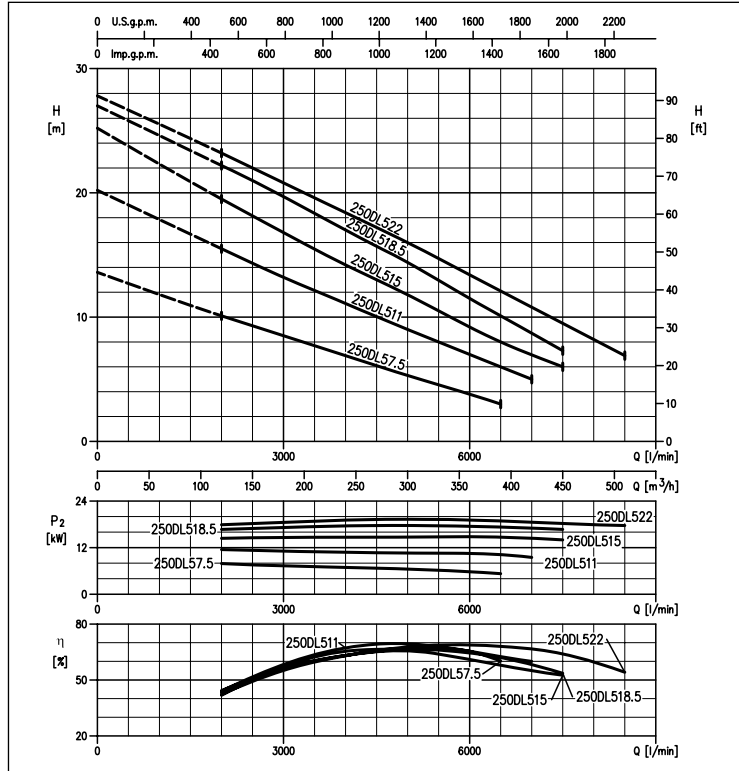

PERFORMANCE CURVES 250DL530 (30 kW) 250DL537 (37 kW) 250DL545 (45 kW)

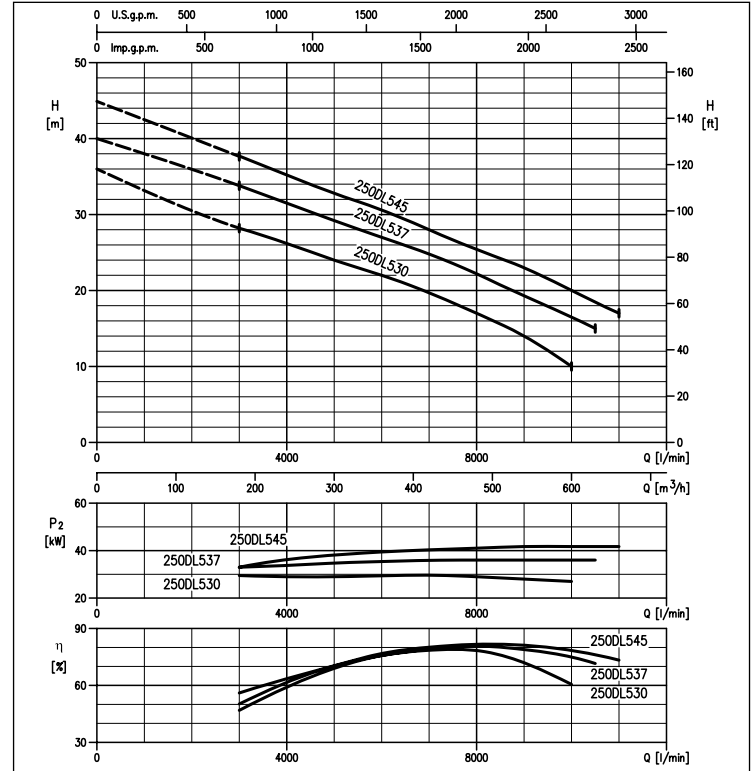

PERFORMANCE CURVES 300DL511 (11 kW) 300DL515 (15 kW) 300DL518.5 (18.5 kW) 300DL522 (22 kW)

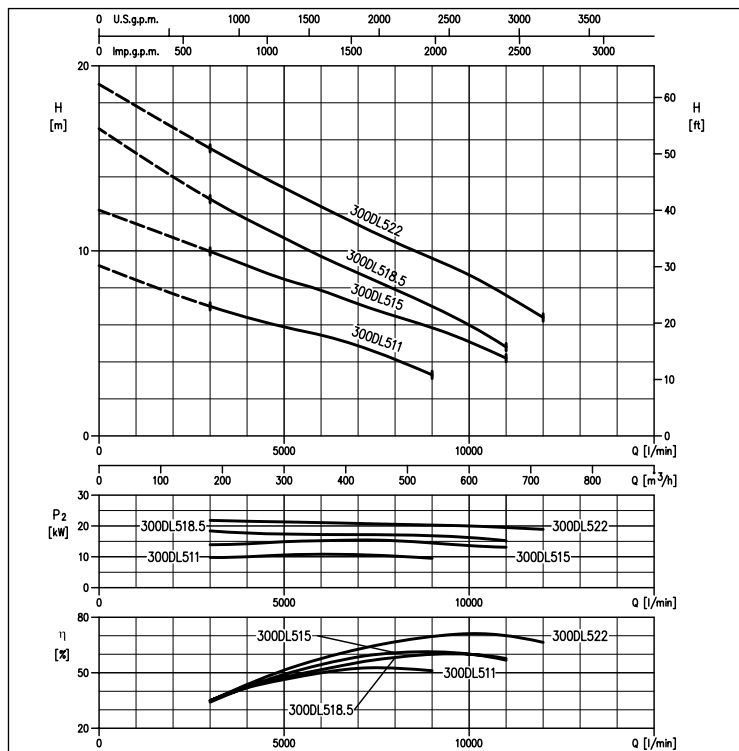

PERFORMANCE CURVES 300DL530 (30 kW) 300DL537 (37 kW) 300DL545 (45 kW)

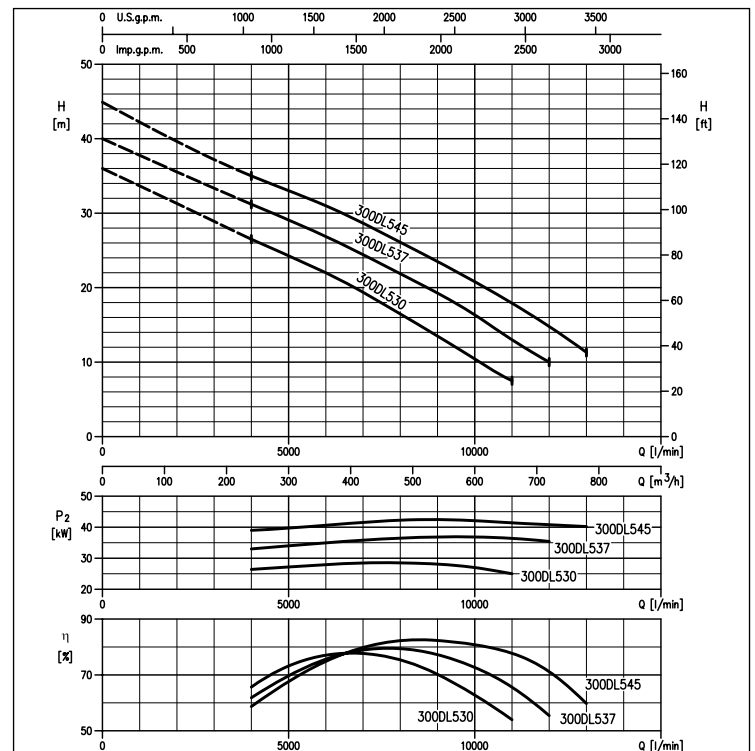

The contents of this publication must not be regarded as binding. EBARA Pumps Europe S.p.A. reserves the right to effect any modification it deems necessary, without prior notice.



DL - DL W/C

SUBMERSIBLE SEWAGE PUMPS (DL) WITH CUTTER (DL W/C)
in cast iron

PERFORMANCE CURVES 65DL51.5 W/C (1.5 kW)

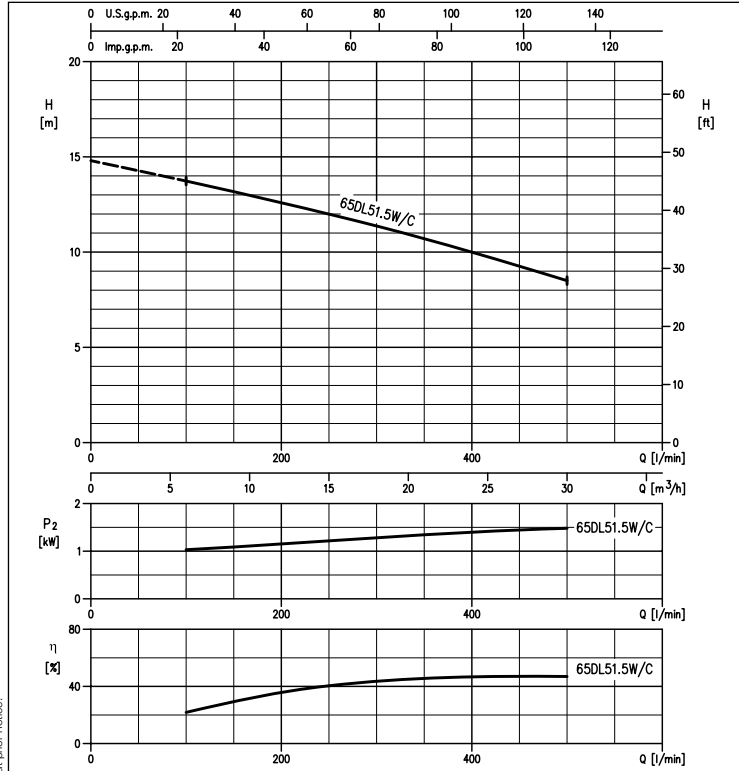

**PERFORMANCE CURVES 80DL51.5 W/C (1.5 kW)
80DL52.2 W/C (2.2 kW)
80DL53.7 W/C (3.7 kW)**

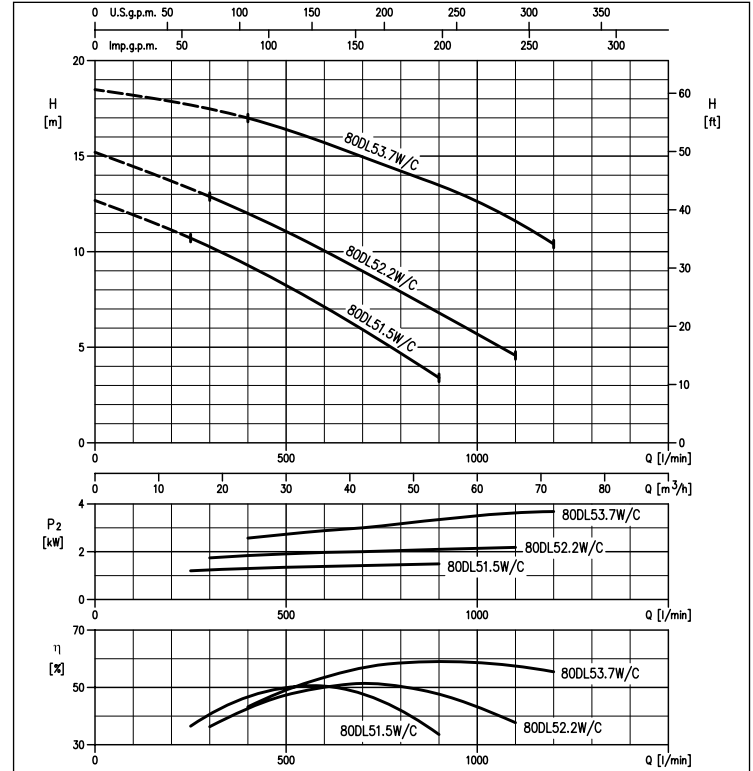

**PERFORMANCE CURVES 100DL53.7 W/C (3.7 kW)
100DLB55.5 W/C (5.5 kW)
100DLB57.5 W/C (7.5 kW)**

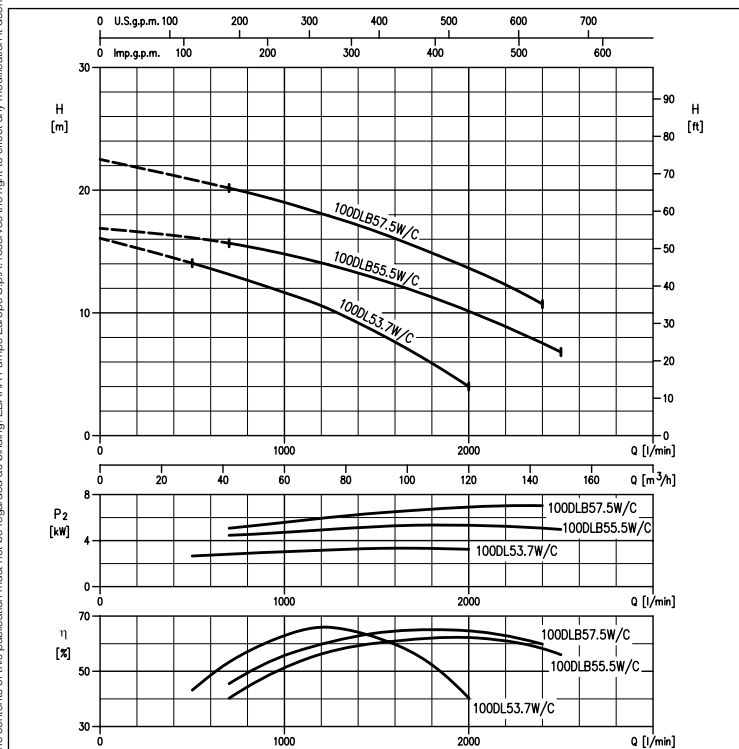

The contents of this publication must not be regarded as binding. EBARA Pumps Europe S.p.A. reserves the right to effect any modification it deems necessary, without prior notice.

DL - DL W/C

SUBMERSIBLE SEWAGE PUMPS (DL) WITH CUTTER (DL W/C)

in cast iron

DIMENSIONS DL

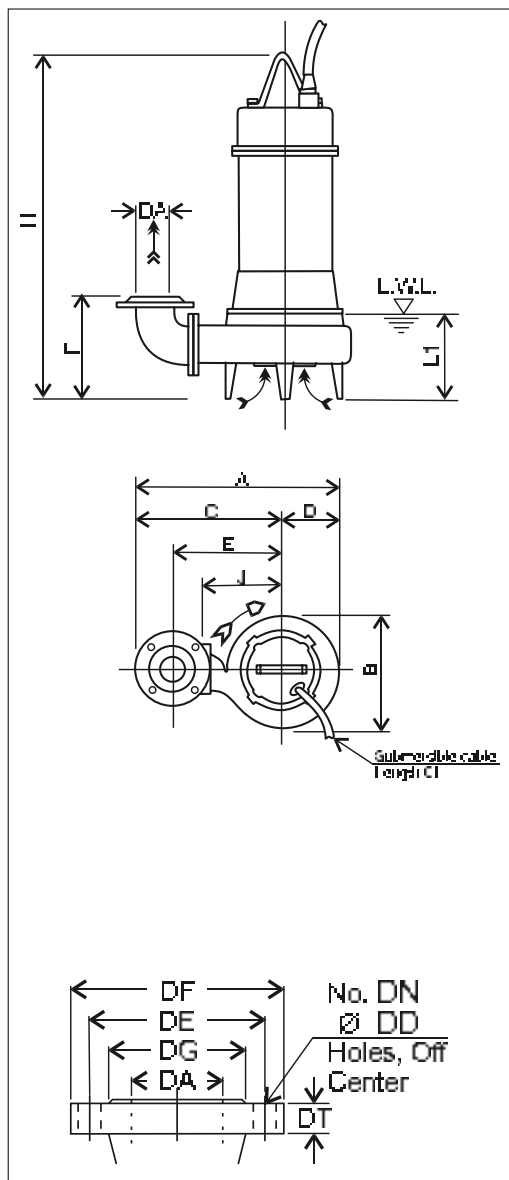

Discharge flanges dimensions [mm] - EN 1092-2							
Type	DA	DE	DF	DG	DT	DN	DD
Round	65	145	185	118	17	4	19
	80	160	200	132	19	8	
	100	180	220	156	21		
	150	240	285	211	23	12	23
	200	295	340	266			
	250	350	395	319	25		
300	400	445	370	24			

DIMENSIONS TABLE DL

DA	Model	[kW]	A	B	C	D	E	F	H	J	L1 (*)	E1	Weight [kg]
65	65DL51.5	1.5	497	291	353	144	265	200	576	200	140		52
80	80DL51.5	1.5	524	292	378	146	285		597	210	165		55
	80DL52.2	2.2	542	308	388	154	295	220	654	220			
	80DL53.7	3.7	567	328	403	164	310		687	235	205		67
	80DLC55.5	5.5	618	379	428	190	335	307	753	260			
	80DLC57.5	7.5	648	399	448	200	355	305	751	280			
100	100DL53.7	3.7	614	335	445	169	340	250	706	235	185		75
	100DLB55.5	5.5	646	369	460	186	355	323	768	250			
	100DLC55.5	5.5	660	379	470	190	365	322	753	260			
	100DLB57.5	7.5	673	385	480	193	375	323	760	270			
	100DLC57.5	7.5	690	399	490	200	385	320	751	280			
	100DL511	11	701	402	500	201	395	323	859	290			
	100DL515	15							954				
	100DL518.5	18.5	741	441	520	221	415	330	958	310			
150	150DL55.5	5.5	750	398	550	200	410	381	799	280	245		79
	150DL57.5	7.5	780	418	570	210	430		784	300			
	150DL511	11						377	883				
	150DL515	15	810	438	590	220	450		972	320			
	150DL518.5	18.5	848	476	610	238	470	381	979	340			
	150DL522	22	848	476	610	238	470	381	979	340			
	150DL530	30							1284	360			
	150DL537	37	912	520	650	262	510	468	1404	360			
200	150DL545	45							1404	360	494		148
	200DL55.5	5.5	832	430	615	217	450	414	826	300			
	200DL57.5	7.5	863	453	635	228	470	410	809	320			
	200DL511	11							908				
	200DL515	15	896	479	655	241	490	411	995	340			
	200DL518.5	18.5							1001				
	200DL522	22	932	512		257			1284	360			
	200DL530	30							1404				
250	200DL537	37	937	520		262			483	360	285		160
	200DL545	45							1404				
	250DL57.5	7.5	969	525	700	269	500	622	904	370			
	250DL511	11	993	541	720	273	520	634	1000	390			
	250DL515	15							1086				
	250DL518.5	18.5	1007	549	730	277	530	646	1089	400			
	250DL522	22							1336				
	250DL530	30							1475				
300	250DL537	37	1125	660	790	335	590	706	1475	460	400		176
	250DL545	45							1475				
	300DL511	11							1050				
	300DL515	15	1100	588	798	302	575	671	1050	420			
	300DL518.5	18.5							1131				
	300DL522	22	1135	618	818	317	595	668	1131	440			
	300DL530	30							1336				
	300DL537	37	1172	660	838	335	615	726	1475	460			
300	300DL545	45							1475		565		260

(*) - L.W.L (Low Water Level)

DL - DL W/C

SUBMERSIBLE SEWAGE PUMPS (DL) WITH CUTTER (DL W/C) in cast iron

DIMENSIONS 65DL, 80DL (1.5÷3.7 kW) with QDC (quick discharge connector)

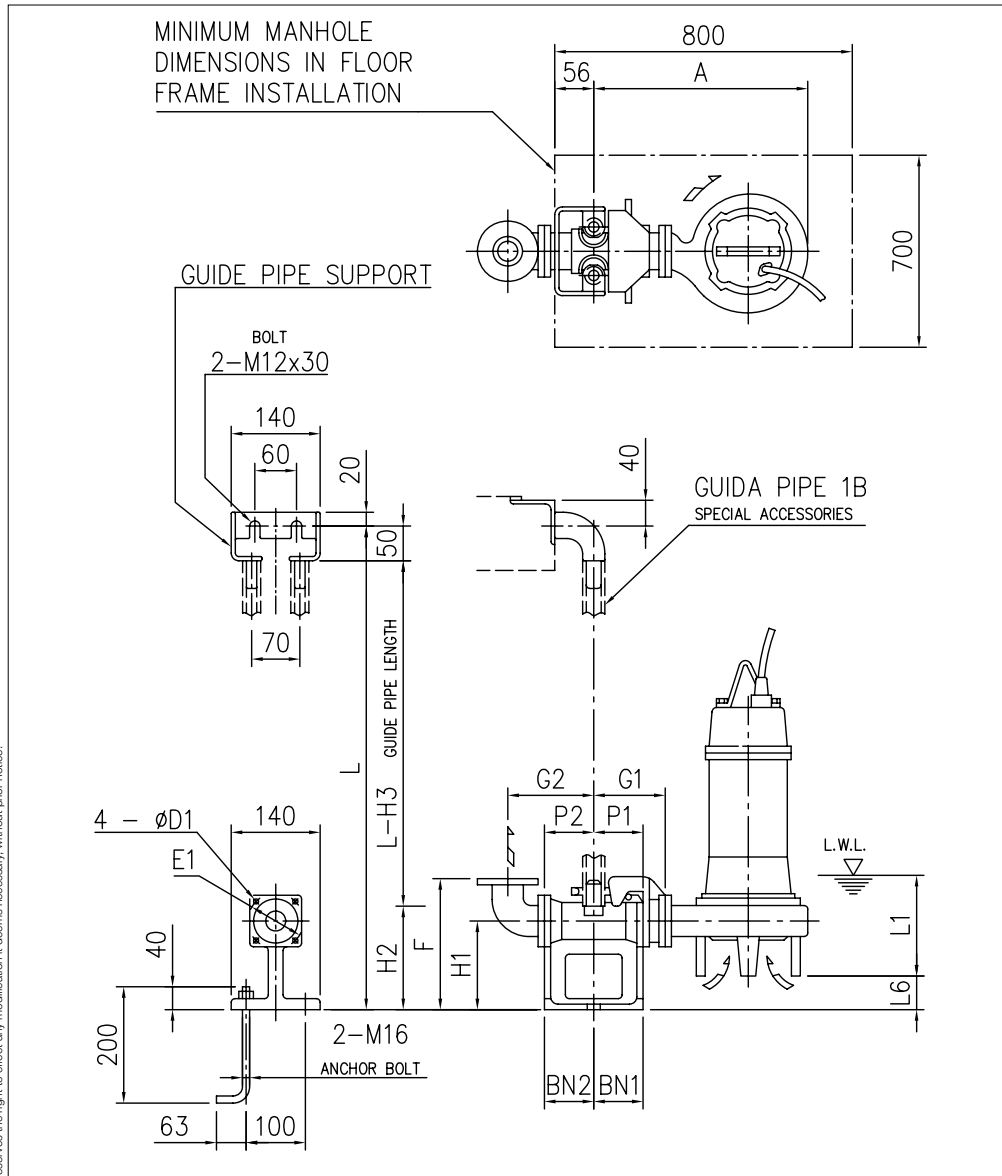

Discharge flanges dimensions [mm] - EN 1092-2							
Type	DA	DE	DF	DG	DT	DN	DD
Round	65	145	185	118	17	4	19
	80	160	200	132	19	8	

DIMENSIONS TABLE 65DL, 80DL (1.5÷3.7 kW) with QDC (quick discharge connector)

DA	Model	[kW]	A	P1	P2	G1	G2	F	H1	H2	H3	L1 (*)	L6	BN1	BN2	D1	E1	QDC (quick discharge connector) Model	Weight [kg]
65	65DL51.5	1,5	464	75	95	120	160	250	145	190	240	140	50	75	95	12	140	LM65	14
	80DL51.5	1,5	481															LM80	17
80	80DL52.2	2,2	499		90	125	165	285	175	230	280	165	65	75	90	15	155	LM65	14
	80DL53.7	3,7	524															LM80	17

(*) - L.W.L. (Low Water Level)

The contents of this publication must not be regarded as binding. EBARA Pumps Europe S.p.A. reserves the right to effect any modification it deems necessary, without prior notice.

DL - DL W/C

SUBMERSIBLE SEWAGE PUMPS (DL) WITH CUTTER (DL W/C) in cast iron

DIMENSIONS 80DL (5.5÷7.5), 100DL with QDC (quick discharge connector)

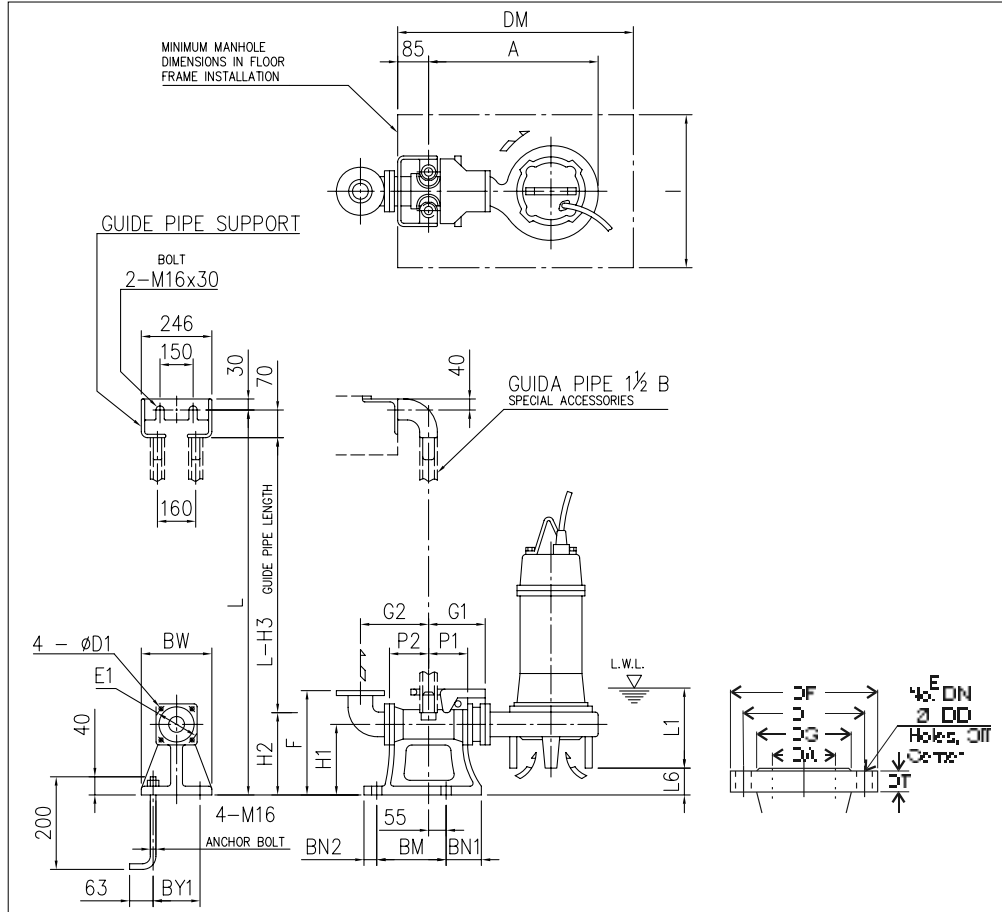

Discharge flanges dimensions [mm] - EN 1092-2							
Type	DA	DE	DF	DG	DT	DN	DD
Round	80	160	200	132	19	8	19
	100	180	220	156	21		

DIMENSIONS TABLE 80DL (5.5÷7.5), 100DL with QDC (quick discharge connector)

DA	Model	[kW]	A	P1	P2	G1	G2	F	H1	H2	H3	L1 (*)	L6	BN1	BN2	BM	BY1	BW	DM	I	D1	E1	QDC (quick discharge connector)																							
																							Model	Weight [kg]																						
80	80DLC55.5	5,5	635		120		195	350		255	325	205	43									15	155	LL80	44																					
	80DLC57.5	7,5	665																							45																				
100	100DL53.7	3,7	589	105	105	185	210	365	240	265	335	185	115	100	40	220	180	230	800	700	19	175	LL100	46																						
	100DLB55.5	5,5	621																						42																					
	100DLC55.5	5,5	635																						43																					
	100DLB57.5	7,5	648																						42																					
	100DLC57.5	7,5	665																						45																					
	100DL511	11	676																						42																					
	100DL515	15																							42																					
	100DL518.5	18,5	716																						35																					

(*) - L.W.L (Low Water Level)

DL - DL W/C

SUBMERSIBLE SEWAGE PUMPS (DL) WITH CUTTER (DL W/C) in cast iron

DIMENSIONS 150DL, 200DL with QDC (quick discharge connector)

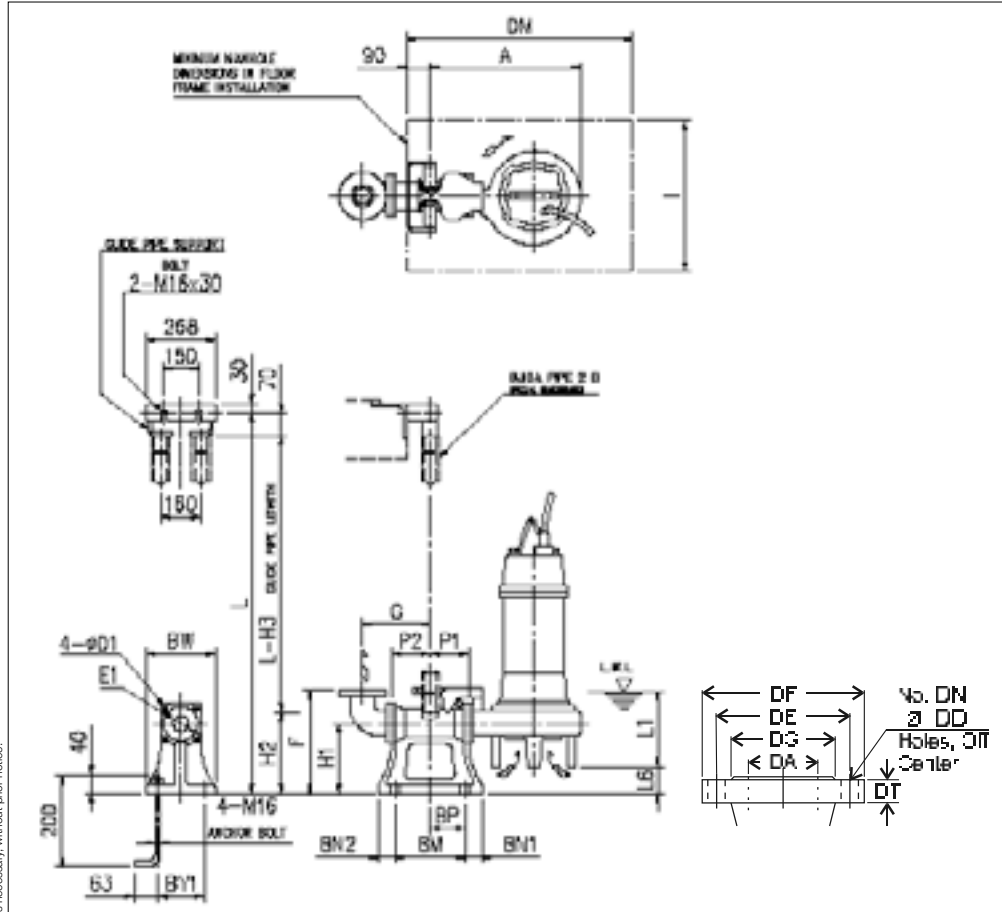

Type	DA	DE	DF	DG	DT	DN	DD
Round	150	240	285	211	23	8	23
	200	295	340	266			

DIMENSIONS TABLE 150DL, 200DL with QDC (quick discharge connector)

DA	Model	[kW]	A	P1	P2	G	F	H1	H2	H3	L1 (*)	L6	BN1	BN2	BM	BP	BY1	BW	DM	I	D1	E1	QDC (quick discharge connector) Model	Weight [kg]																	
150	150DL55.5	5.5	635	155	195	325	450	290	362	432	245	69	60	370	165	280	330	1000	700	210	LL125	65																			
	150DL57.5	7.5	665									73																													
	150DL511	11	695									69																													
	150DL515	15	733									205													355	480	320	405	475	288	210	60	390	170	300	350	1100	800	250	LL150	80
	150DL518.5	18.5	777									205													355	480	320	405	475	296	210	60	390	170	300	350	1100	800	250	LL150	80
	150DL522	22	777									296													210	60															
	150DL530	30	777									296													210	60															
	150DL537	37	777									296													210	60															
150DL545	45	777	296	210	60																																				
200	200DL55.5	5.5	672	155	205	355	495	320	405	475	285	81	60	390	170	300	350	1100	800	250	LL150	80																			
	200DL57.5	7.5	703									85																													
	200DL511	11	736									84																													
	200DL515	15	772									80																													
	200DL518.5	18.5	777									288													210	60															
	200DL522	22	777									288													210	60															
	200DL530	30	777									296													210	60															
	200DL537	37	777									296													210	60															
	200DL545	45	777									296													210	60															

(*) - L.W.L (Low Water Level)

The contents of this publication must not be regarded as binding. EBARA Pumps Europe S.p.A. reserves the right to effect any modification it deems necessary, without prior notice.

DL - DL W/C

SUBMERSIBLE SEWAGE PUMPS (DL) WITH CUTTER (DL W/C) in cast iron

DIMENSIONS 250DL, 300DL with QDC (quick discharge connector)

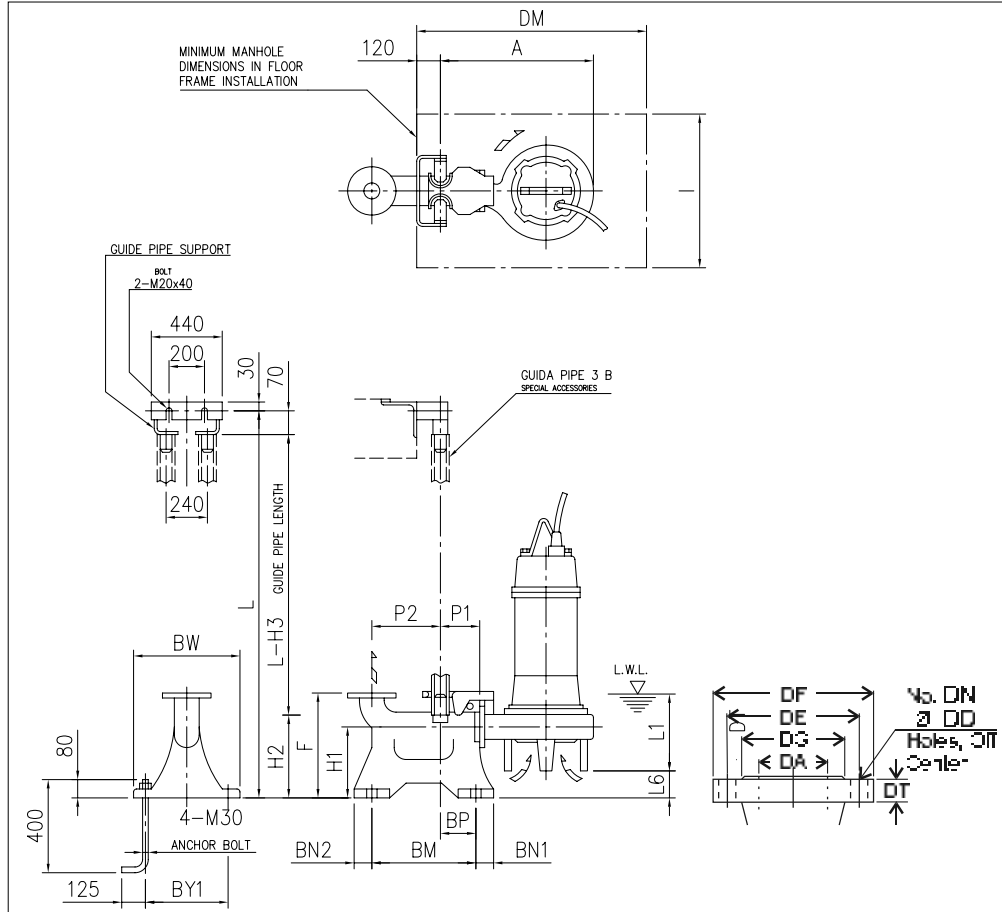

Discharge flanges dimensions [mm] - EN 1092-2							
Type	DA	DE	DF	DG	DT	DN	DD
Round	250	350	395	319	25	12	23
	300	400	445	370	24		

DIMENSIONS TABLE 250DL, 300DL with QDC (quick discharge connector)

DA	Model	[kW]	A	P1	P2	F	H1	H2	H3	L1 (*)	L6	BN1	BN2	BM	BP	BY1	BW	DM	I	QDC (quick discharge connector) Model	QDC (quick discharge connector) Weight [kg]
250	250DL57.5	7.5	834	195	435	700	350	440	510	400	58	70	70	650	215	500	560	1200	900	LL250	150
	250DL511	11	46																		
	250DL515	15	34																		
	250DL518.5	18,5	872		465	800	430	550	620	450	292			300	680	580	640	1200	900	LL300	200
	250DL522	22	319																		
	250DL530	30	109																		
	250DL537	37	112																		
250DL545	45	990	970	970	970	970	970	319	300	300	300	300	300	300	300	300	300	300	300	300	
300DL511	11	917																			
300DL515	15	952																			
300DL518.5	18,5	990																			
300DL522	22																				
300DL530	30																				
300DL537	37																				
300DL545	45																				

(*) - L.W.L (Low Water Level)

DL - DL W/C

SUBMERSIBLE SEWAGE PUMPS (DL) WITH CUTTER (DL W/C)

in cast iron

DIMENSIONS DL W/C (with cutter)

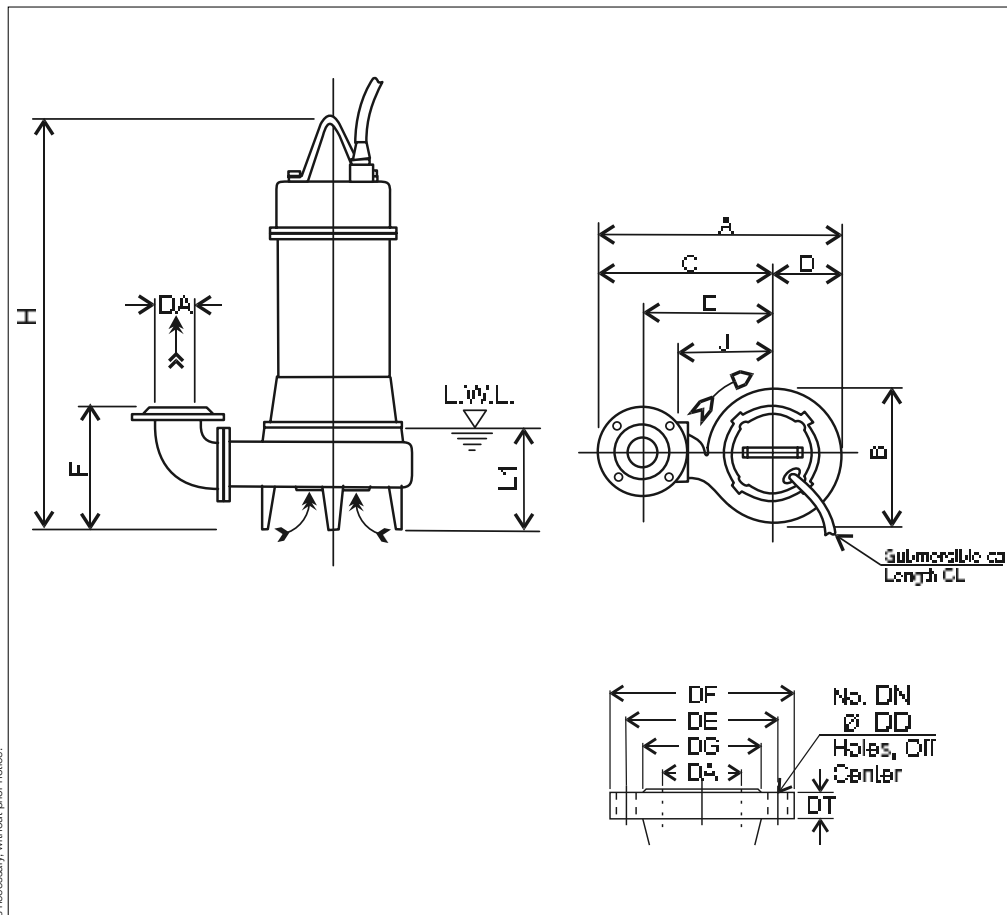

Discharge flanges dimensions [mm] - EN 1092-2							
Type	DA	DE	DF	DG	DT	DN	DD
Round	64	145	185	118	17	4	19
	80	160	200	132	19	8	
	100	180	220	156	21		

DIMENSIONS TABLE DL W/C (with cutter)

DA	Model	[kW]	A	B	C	D	E	F	H	J	L1 (*)	CL [m]	Weight [kg]
65	65DL51.5W/C	1.5	497	291	353	144	265	200	576	200	140	10	52
80	80DL51.5W/C	1.5	524	292	378	146	285	220	597	210	165		55
	80DL52.2W/C	2.2	542	308	388	154	295		654	220			67
	80DL53.7W/C	3.7	567	328	403	164	310		687	235			75
100	100DL53.7W/C	3.7	614	335	445	169	340	250	706	205	185		79
	100DLB55.5W/C	5.5	646	369	460	186	355	323	768		250		205
	100DLB57.5W/C	7.5	673	385	480	193	375	760	270		205	141	

(*) - L.W.L (Low Water Level)

The contents of this publication must not be regarded as binding. EBARA Pumps Europe S.p.A. reserves the right to effect any modification it deems necessary, without prior notice.

DL - DL W/C

SUBMERSIBLE SEWAGE PUMPS (DL) WITH CUTTER (DL W/C) in cast iron

DIMENSIONS 65DL W/C, 80DL W/C (with cutter) (1.5÷3.7 kW) with QDC (quick discharge connector)

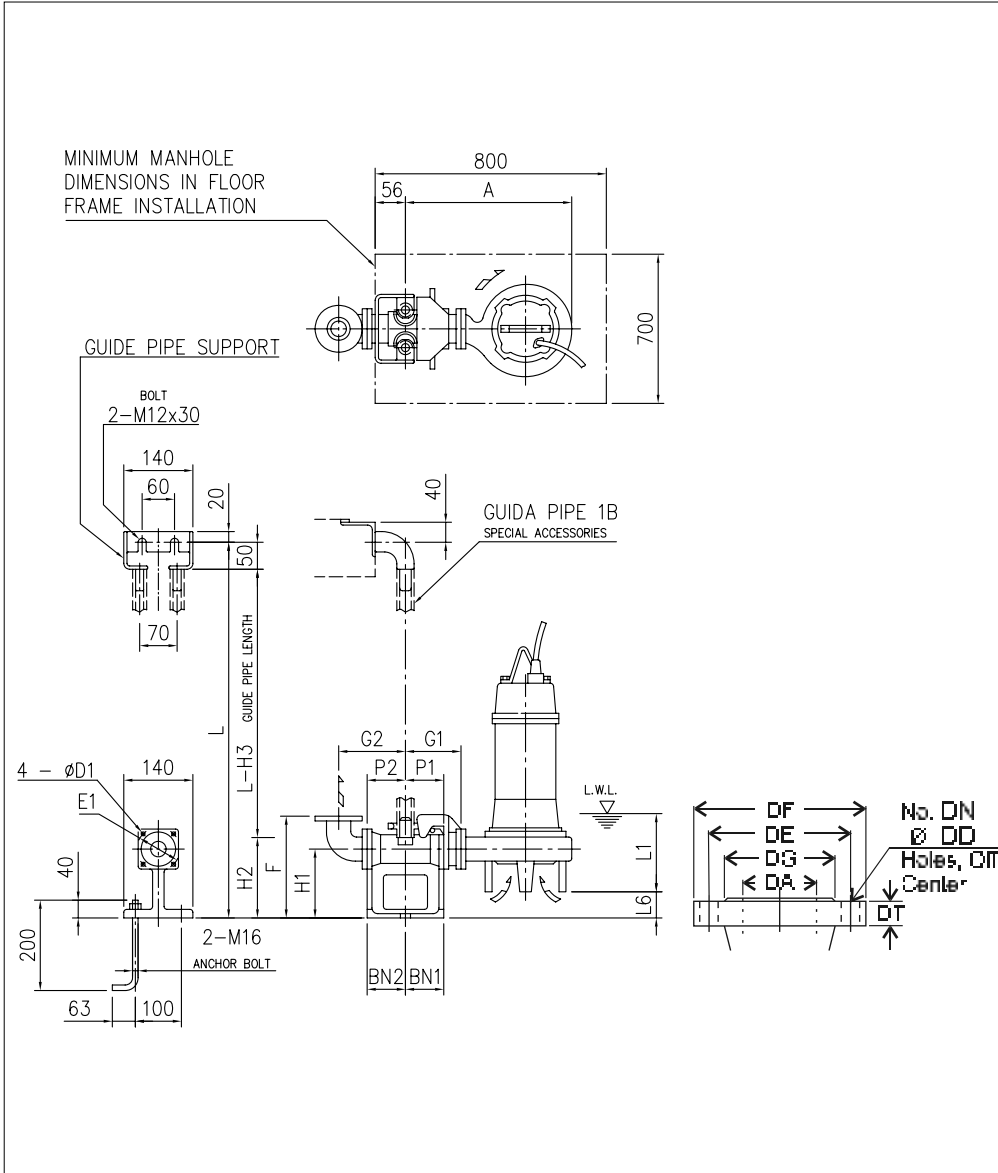

Discharge flanges dimensions [mm] - EN 1092-2							
Type	DA	DE	DF	DG	DT	DN	DD
Round	65	145	185	118	17	4	19
	80	160	200	132	19	8	

DIMENSIONS TABLE 65DL W/C, 80DL W/C (with cutter) (1.5÷3.7 kW) with QDC (quick discharge connector)

DA	Model	[kW]	A	P1	P2	G1	G2	F	H1	H2	H3	L1 (*)	L6	BN1	BN2	D1	E1	QDC (quick discharge connector) Model	Weight [kg]
65	65DL51.5W/C	1,5	464	75	95	120	160	250	145	190	240	140	50	75	95	12	140	LM65	14
	80DL51.5W/C	1,5	481															LM80	17
80	80DL52.2W/C	2,2	499		90	125	165	285	175	230	280	165	65		90	15	155	LM80	17
	80DL53.7W/C	3,7	524																

(*) - L.W.L (Low Water Level)

DL - DL W/C

SUBMERSIBLE SEWAGE PUMPS (DL) WITH CUTTER (DL W/C) in cast iron

DIMENSIONS 100DL W/C with QDC (quick discharge connector)

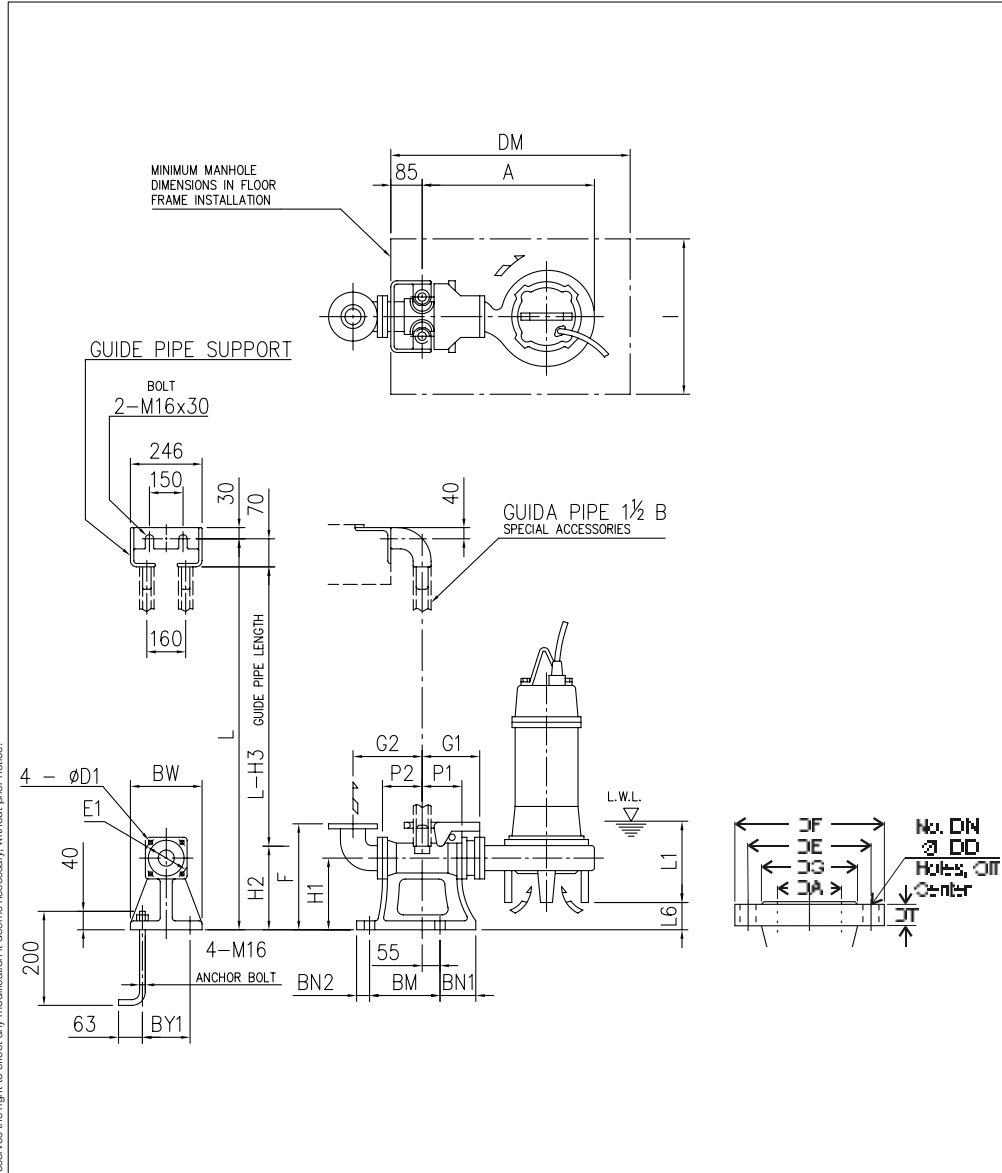

Discharge flanges dimensions [mm] - EN 1092-2							
Type	DA	DE	DF	DG	DT	DN	DD
Round	80	160	200	132	19	8	19
	100	180	220	156	21		
	150	240					

DIMENSIONS TABLE 100DL W/C (with cutter) with QDC (quick discharge connector)

DA	Model	[kW]	A	P1	P2	G1	G2	F	H1	H2	H3	L1(*)	L6	BN1	BN2	BM	BY1	BW	DM	I	D1	E1	QDC Model	Weight [kg]
100	100DL53.7W/C	3.7	589	105	105	185	210	365	240	265	335	185	115	100	40	220	180	230	800	700	19	175	LL100	46
	100DLB55.5W/C	5.5	621									205	42											
	100DLB57.5W/C	7.5	648									205	42											

(*) - L.W.L (Low Water Level)

The contents of this publication must not be regarded as binding. EBARA Pumps Europe S.p.A. reserves the right to effect any modification it deems necessary, without prior notice.

DL - DL W/C

SUBMERSIBLE SEWAGE PUMPS (DL) WITH CUTTER (DL W/C)

in cast iron

SECTIONAL VIEW 65DL, 65DL W/C (1.5 kW)
80DL, 80DL W/C (1.5÷3.7 kW)
100DL, 100DL W/C (3.7 kW)

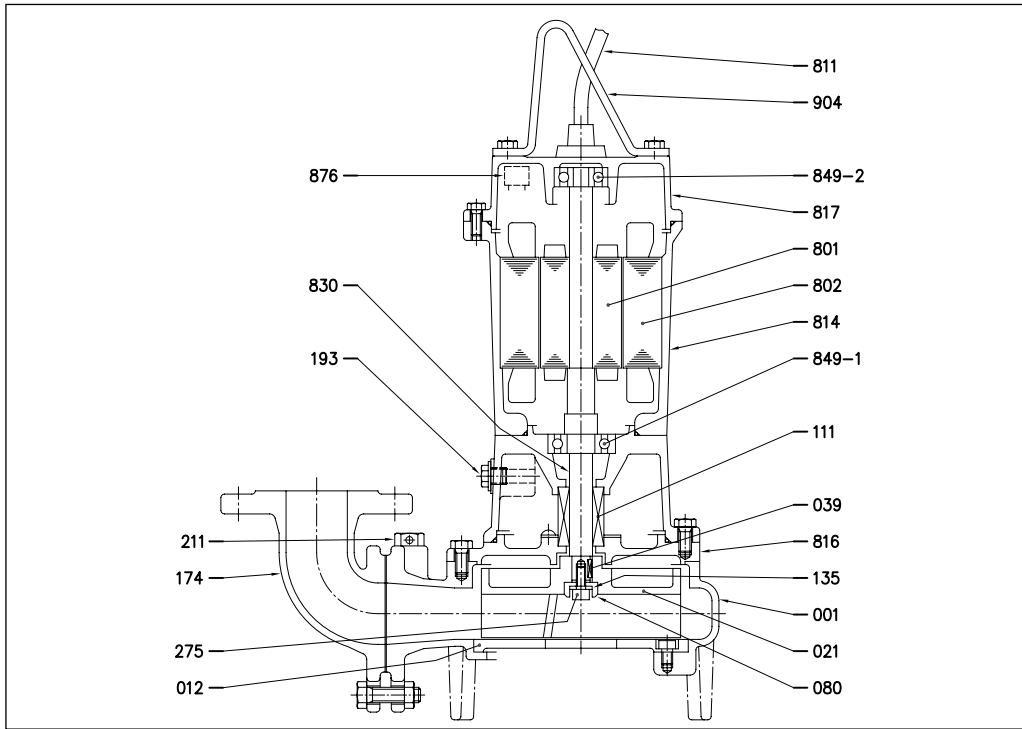

SECTIONAL VIEW 80DL (5.5÷7.5 kW) 100DL (5.5÷18.5 kW) 100DL W/C (5.5÷7.5 kW)
150DL (5.5÷22 kW) 200DL (5.5÷22 kW)
250DL (7.5÷22 kW) 300DL (11÷22 kW)

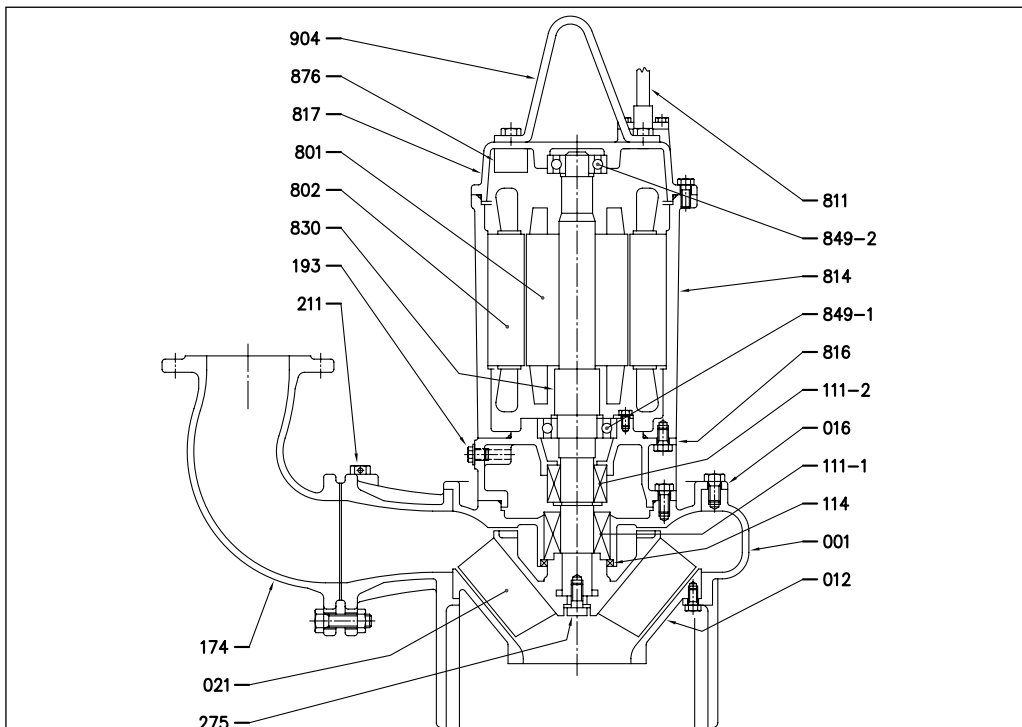

DL - DL W/C

SUBMERSIBLE SEWAGE PUMPS (DL) WITH CUTTER (DL W/C)

in cast iron

SECTIONAL VIEW 150DL (30÷45 kW), 200DL (30÷45 kW)
250DL (30÷45 kW), 300DL (30÷45 kW)

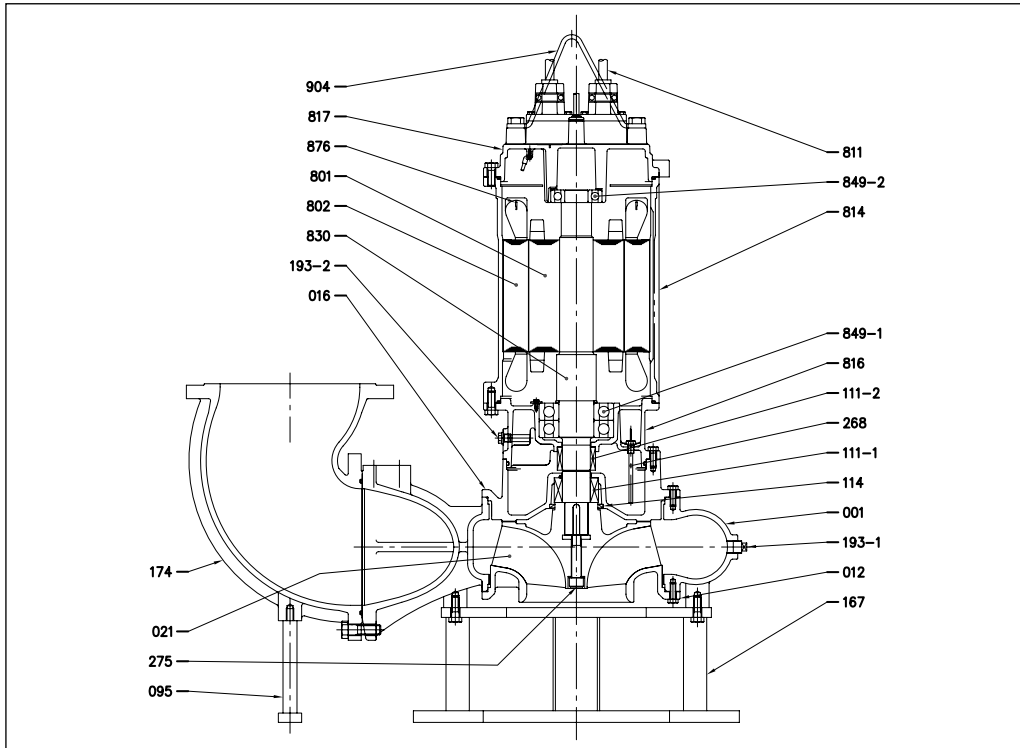

MATERIALS TABLE DL - DL W/C (with cutter)

Ref.	Name	Material	Ref.	Name	Material
001	Pump body	CAST IRON EN-GHJL-200-EN 1561	193-2	Oil plug + Gasket	NBR/EN 1.4301(AISI304)
012	Suction side lid	CAST IRON EN-GHJL-200-EN 1561	211	Airvent valve [1]	-
016	Mechanical seal cover	CAST IRON EN-GHJL-200-EN 1561	275	Impeller nut	EN 1.4301 (AISI304)
021	Impeller	CAST IRON EN-GHJL-200-EN 1561	801	Rotor	-
039	Key	EN 1.4028 (AISI420)	802	Stator	-
080	Bushing	EN 1.4301 (AISI304)	811	Cable	-
095	Stay [1]	EN 1.4301 (AISI304)	814	Motor case	CAST IRON EN-GHJL-200-EN 1561
111	Mechanical seal	-	816	Motor support	CAST IRON EN-GHJL-200-EN 1561
111-1	Mechanical seal	-	817	Motor cover	CAST IRON EN-GHJL-200-EN 1561
111-2	Mechanical seal	-	830	Shaft	EN 1.4006 (AISI403)
114	Gasket	NBR	849-1	Ball bearing	-
135	Seal washer	EN 1.4301 (AISI304)	849-2	Ball bearing	-
174	Discharge bend	CAST IRON EN-GHJL-200-EN 1561	876	Protector	-
193	Oil plug	NBR/EN 1.4301 (AISI304)	904	Lifting hanger	STAINLESS STEEL
193-1	Plug	EN 1.4301 (AISI304)			

[1] - Excluded 150DL, 200DL, 250DL e 300DL

The contents of this publication must not be regarded as binding. EBARA Pumps Europe S.p.A. reserves the right to effect any modification it deems necessary, without prior notice.

DL - DL W/C

SUBMERSIBLE SEWAGE PUMPS (DL) WITH CUTTER (DL W/C)

in cast iron

DL, DL W/C (with cutter) (1.5÷3.7 kW) MOTOR DATA

[P2]	[kW]	1.5			2.2			3.7				
Resistance at 20°C	[Ω]	8.466			5.937			3.447				
GD ²	[kg•m ²]	0.013			0.025			0.04				
Voltage	[V]	380	400	415	380	400	415	380	400	415		
Load	0%	Current	[A]	2.3	2.51	2.746	2.65	2.85	3.2	3.5	3.65	3.9
		Power	[W]	500	420	546	650	450	420	650	800	450
	75%	Current	[A]	3.47	3.37	3.56	4.65	4.34	4.46	6.70	6.73	6.25
		Efficiency	[%]	62.67	70.31	62.99	63.89	69.75	69.23	73.21	69.72	76.38
		Power factor	[%]	78.70	68.43	69.87	84.32	78.63	74.40	85.95	85.37	80.93
	100%	Speed	[min ⁻¹]	1438	1449	1446	1440	1452	1458	1447	1449	1455
		Current	[A]	4.10	3.90	4.10	5.70	5.20	5.20	8.40	8.30	7.60
		Efficiency	[%]	65.69	72.58	65.73	66.44	72.31	71.82	74.67	72.09	77.98
		Power factor	[%]	84.62	76.54	77.83	88.26	84.45	81.96	89.62	89.25	86.85
	Speed	[min ⁻¹]	1414	1432	1426	1417	1437	1443	1427	1430	1440	
	Locked Rotor Torque	[%]	319	378	385	216	277	301	229	275	296	
	Start Current	[A]	23.70	24.50	23.60	29.30	30.00	32.00	49.40	47.50	49.00	
No. starts per hour		10										
Model		ZDLEU										

DL (5.5÷11 kW), DL W/C (with cutter) (5.5÷7.5 kW) MOTOR DATA

[P2]	[kW]	5.5			7.5			11				
Resistance at 20°C	[Ω]	2.339			1.513			-	0.869			
GD ²	[kg•m ²]	0.61			0.071			0.12				
Voltage	[V]	380	400	415	380	400	415	380	400	415		
Load	0%	Current	[A]	4.9	4.3	4.5	7.85	6.5	7.1	-	7.80	8.60
		Power	[W]	470	900	470	707	1200	707	-	1500	790
	75%	Current	[A]	9.38	8.97	8.58	13.38	12.46	12.07	-	17.03	16.81
		Efficiency	[%]	79.17	75.51	79.10	79.46	76.94	79.81	-	80.39	81.35
		Power factor	[%]	84.39	87.90	84.53	80.38	84.72	81.25	-	86.98	83.95
	100%	Speed	[min ⁻¹]	1464	1458	1464	1467	1463	1467	-	1468	1470
		Current	[A]	11.70	11.30	10.70	16.40	15.50	14.80	-	21.50	21.00
		Efficiency	[%]	80.42	77.14	80.38	80.98	78.64	81.26	-	82.12	82.29
		Power factor	[%]	88.83	91.07	88.97	85.80	88.81	86.76	-	89.92	88.56
	Speed	[min ⁻¹]	1451	1442	1451	1455	1449	1455	-	1456	1458	
	Locked Rotor Torque	[%]	271	249	271	288	272	288	-	185	155	
	Start Current	[A]	81.00	70.00	74.00	120.00	104.00	108.00	-	121.0	128.0	
No. starts per hour		10						6				
Model		ZDLEU										

DL - DL W/C

SUBMERSIBLE SEWAGE PUMPS (DL) WITH CUTTER (DL W/C)

in cast iron

DL (15÷22 kW) MOTOR DATA

[P2]	[kW]	15			18.5			22					
Resistance at 20°C	[Ω]	-	0.677			-	0.439			-	0.376		
GD ²	[kg·m ²]	0.15			0.25			0.28					
Voltage	[V]	380	400	415	380	400	415	380	400	415			
Load	0%	Current	[A]	-	8.50	8.85	-	12.80	15.10	-	12.50	13.50	
		Power	[W]	-	1600	880	-	2000	1300	-	2000	965	
	75%	Current	[A]	-	22.13	21.11	-	27.76	27.38	-	32.73	31.37	
		Efficiency	[%]	-	81.59	84.15	-	84.25	85.39	-	82.74	85.54	
		Power factor	[%]	-	89.91	88.12	-	85.61	82.55	-	87.94	85.56	
	100%	Speed	[min ⁻¹]	-	1464	1464	-	1477	1480	-	1471	1473	
		Current	[A]	-	28.50	27.00	-	35.00	34.00	-	42.00	40.00	
		Efficiency	[%]	-	82.79	84.99	-	85.77	86.79	-	84.17	86.11	
		Power factor	[%]	-	91.76	90.93	-	88.95	87.23	-	89.82	88.86	
	Speed	[min ⁻¹]	-	1450	1451	-	1469	1472	-	1460	1463		
	Locked Rotor Torque	[%]	-	171	182	-	171	185	-	155	169		
	Start Current	[A]	-	160.0	167.0	-	238.0	248.0	-	265.0	265.0		
No. starts per hour		6											
Model		ZDLEU											

DL (30÷45 kW) MOTOR DATA

[P2]	[kW]	30			37			45				
Resistance at 20°C	[Ω]	0,236			0,152			0,117				
GD ²	[kg·m ²]	0,72			1,11			1,32				
Voltage	[V]	380	400	415	380	400	415	380	400	415		
Load	0%	Current	[A]	20	23,7	27,3	25,4	31,4	36,3	29,7	36,2	41,9
		Power	[W]	925	1104	1332	1116	1584	1956	1320	1752	2172
	75%	Current	[A]	45,69	45,96	47,48	56,47	58,11	60,14	68,59	70,07	72,18
		Efficiency	[%]	89,77	89,48	87,78	91,33	90,25	89,33	90,25	88,93	88,13
		Power factor	[%]	83,35	78,97	75,10	81,75	76,38	71,87	82,84	78,17	73,81
	100%	Speed	[min ⁻¹]	1462	1464	1466	1479	1480	1481	1476	1478	1479
		Current	[A]	59,00	58,00	58,50	72,50	72,50	73,50	88,00	87,50	88,50
		Efficiency	[%]	89,28	89,39	88,21	91,57	90,89	90,29	90,63	89,83	89,28
		Power factor	[%]	86,41	83,45	80,60	86,64	80,95	77,56	85,56	82,33	79,12
	Speed	[min ⁻¹]	1447	1451	1453	1470	1472	1473	1467	1470	1471	
	Locked Rotor Torque	[%]	245	272	294	154	171	184	156	173	186	
	Start Current	[A]	356,50	377,40	393,20	390,70	413,90	431,30	497,80	527,40	549,70	
No. starts per hour		6										
Model		ZDLEU										