



**EBARA**

	<b>Page</b>
<b>- CONTENTS</b>	<b>100</b>
<b>- SPECIFICATIONS</b>	<b>200</b>
SELECTION CHARTS	201
PERFORMANCE CHART CD 70	202
PERFORMANCE CHART CD 90	203
PERFORMANCE CHART CD 120	204
PERFORMANCE CHART CD 200	205
<b>- CONSTRUCTIONS</b>	<b>300</b>
SECTIONAL VIEW	300
MECHANICAL SEAL	301
SINGLE PHASE DIAGRAM AND ELECTRIC CONNECTIONS	302
THREE PHASE DIAGRAM AND ELECTRIC CONNECTIONS	303
<b>- DIMENSIONS</b>	<b>400</b>
PACKING AND WEIGHT	401
<b>- TECHNICAL DATA</b>	<b>500</b>

## SPECIFICATIONS

50 Hz

PUMP		
Liquid Handled	Type of liquid	Clean water
	Max temperature [°C]	60 (CD 70/05-70/07-90/10) 90 110 (CDH and CDHS)
	Min temperature [°C]	-10
Maximum working pressure [MPa]		0.8
Construction	Impeller	Closed centrifugal type
	Shaft seal type	Mechanical seal
	Bearing	Sealed ball bearing
Pipe Connection	Suction	G 1¼, G 1½ (CD200)
	Discharge	G 1
Material	Casing	AISI 304
	Impeller	AISI 304
	Casing cover	AISI 304
	Shaft seal	Ceramic/Carbon/NBR Ceramic/Carbon/FPM (for CDH) SiC/SiC/FPM (for CDHS)
	Casing cover	AISI 304
	Shaft	AISI 303 (Wet extension)
	Bracket	AISI 304
Applicable standard of test		ISO 9906 – Annex A

MOTOR		
Type	Electric - TEFC	
	Single Phase	Three Phase
No. of Poles	2	
Rotation speed [min <sup>-1</sup> ]	≈ 2800	
Insulation Class	F	
Protection degree	IP 55	
Power rating	[kW]	0.37 ÷ 1.5
	[HP]	0.5 ÷ 2
Frequency [Hz]	50	
Voltage [V]	230 ±10%	230/400 ±10%
Capacitor	Built in	-
Over load protection	Built in	Provided by the user
Casing material	AISI 304	
Base material/motor support	AISI 304	
Dimensions of cable entry	PG11	

## SELECTION CHART

50 Hz

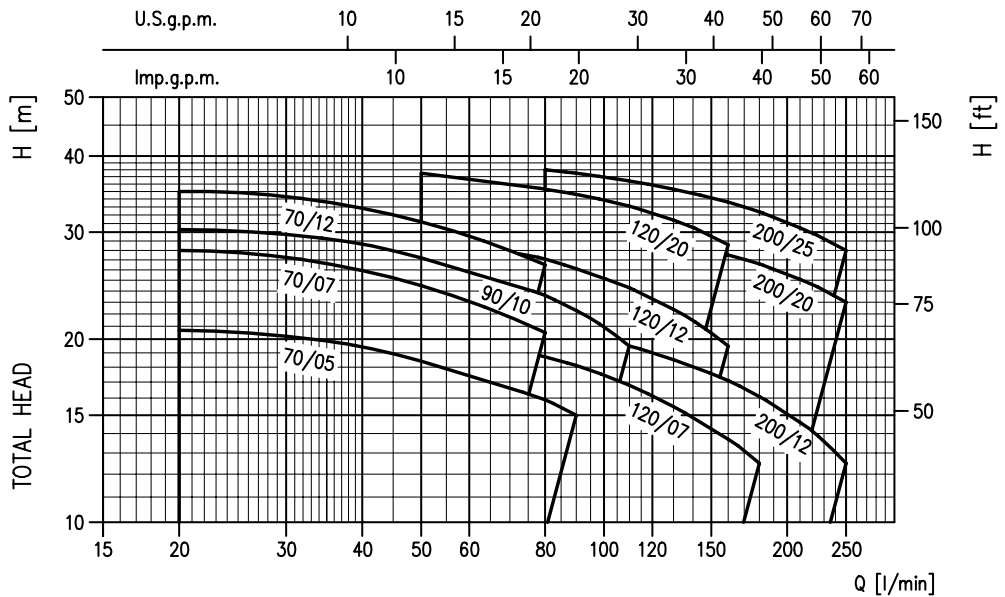

Type pumps		Power		Q=Capacity										
Single Phase	Three Phase	[kW]	[HP]	l/min	20	50	80	90	110	130	160	180	210	250
				m <sup>3</sup> /h	1.2	3.0	4.8	5.4	6.6	7.8	9.6	10.8	12.6	15.0
				H=Total manometric head in meters										
CDM 70/05	CD 70/05	0.37	0.5	20.7	18.4	15.9	15	-	-	-	-	-	-	-
CDM 70/07	CD 70/07	0.55	0.8	28	24.5	20.5	-	-	-	-	-	-	-	-
CDM 70/12	CD 70/12	0.9	1.2	35	31.2	26.5	-	-	-	-	-	-	-	-
CDM 90/10	CD 90/10	0.75	1	30.3	27.2	23.6	22.3	19.5	-	-	-	-	-	-
CDM 120/07	CD 120/07	0.55	0.8	-	20.5	18.7	18.1	16.8	15.5	13.7	12.5	-	-	-
CDM 120/12	CD 120/12	0.9	1.2	-	29.5	27.1	26.1	24.3	22.4	19.5	-	-	-	-
CDM 120/20	CD 120/20	1.5	2	-	37.5	35.3	34.6	33.1	31.4	28.6	-	-	-	-
CDM 200/12	CD 200/12	0.9	1.2	-	-	20.6	20.2	19.5	18.5	17.1	16.1	14.6	12.5	-
CDM 200/20	CD 200/20	1.5	2	-	-	31	30.6	29.7	28.9	27.5	26.6	25.1	23	-
-	CD 200/25	1.8	2.5	-	-	38	37.5	36.4	35.3	33.6	32.4	30.5	28	-

### TYPE KEY

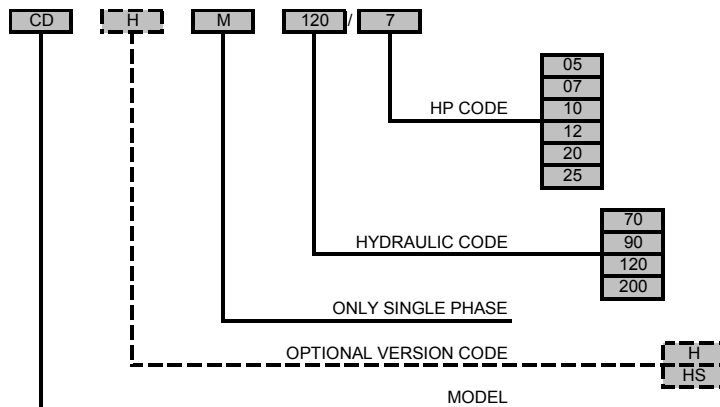

CD 70 PERFORMANCHE CURVES

50 Hz

CD 70/05 (0.37 kW) Impeller diameter = 132  
 CD 70/07 (0.55 kW) Impeller diameter = 157  
 CD 70/12 (0.9 kW) Impeller diameter = 176

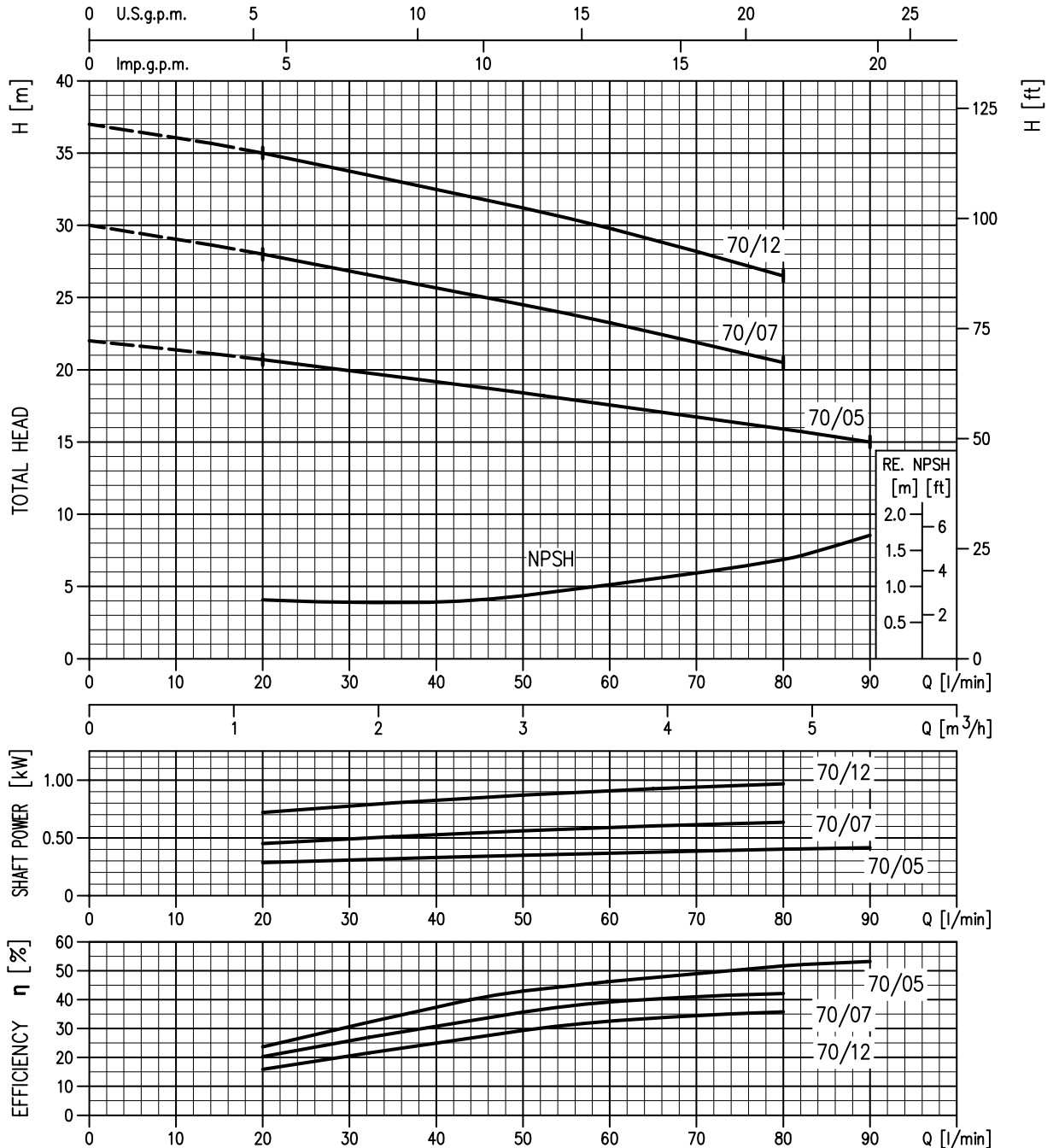

Rotation speed:  $\approx 2800 \text{ min}^{-1}$   
 Test fluid: clean water at 20°C  
 Applicable standard of test: ISO 9906 grade 2

CD 90 PERFORMANCHE CURVES

50 Hz

CDX 90/10 (0.75 kW) Impeller diameter = 157

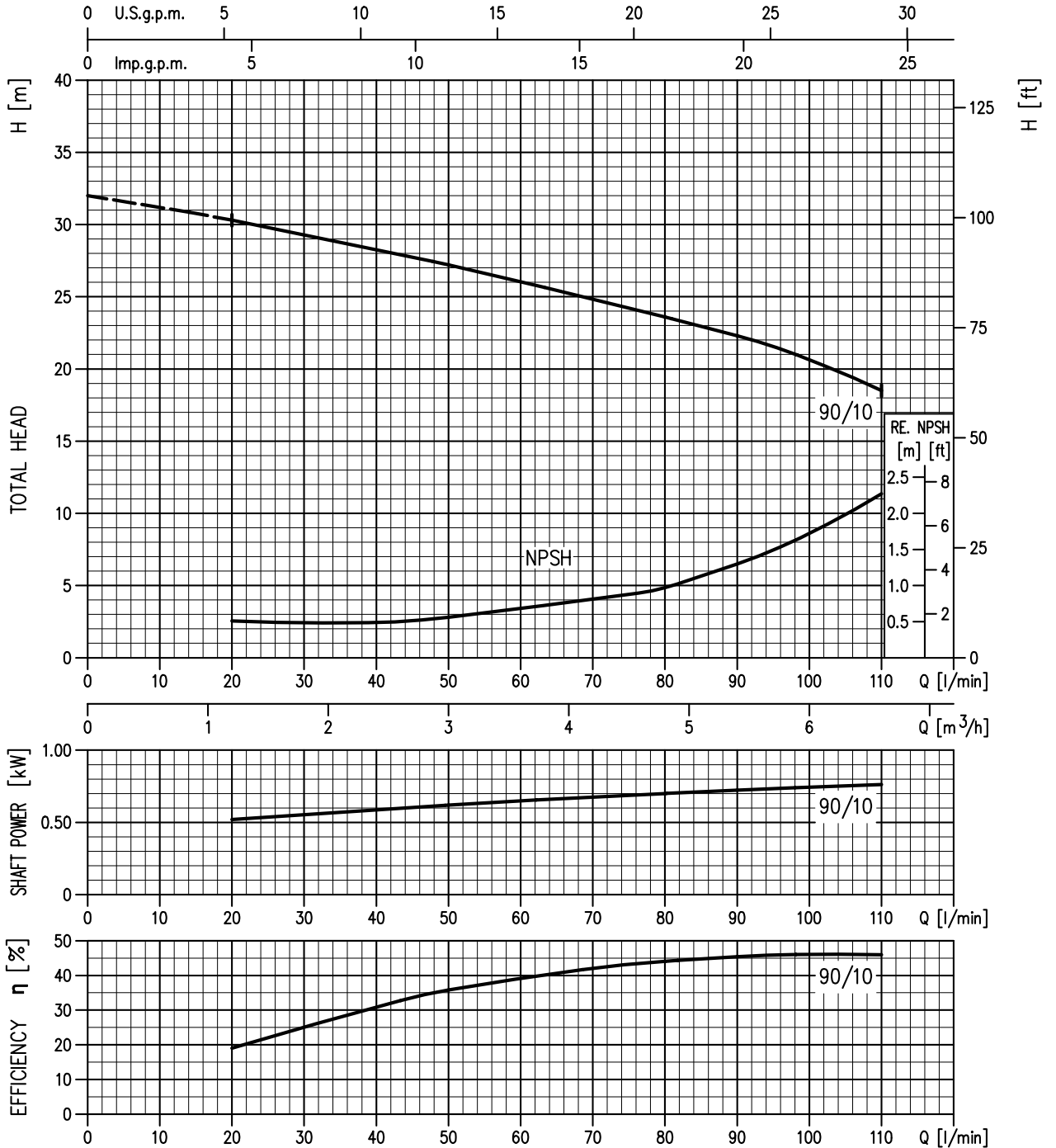

Rotation speed:  $\approx 2800 \text{ min}^{-1}$   
 Test fluid: clean water at 20°C  
 Applicable standard of test: ISO 9906 grade 2

CD 120 PERFORMANCHE CURVES

50 Hz

CDX 120/07 (0.75 kW) Impeller diameter = 132  
 CDX 120/12 (0.90 kW) Impeller diameter = 157  
 CDX 120/20 (1.50 kW) Impeller diameter = 176

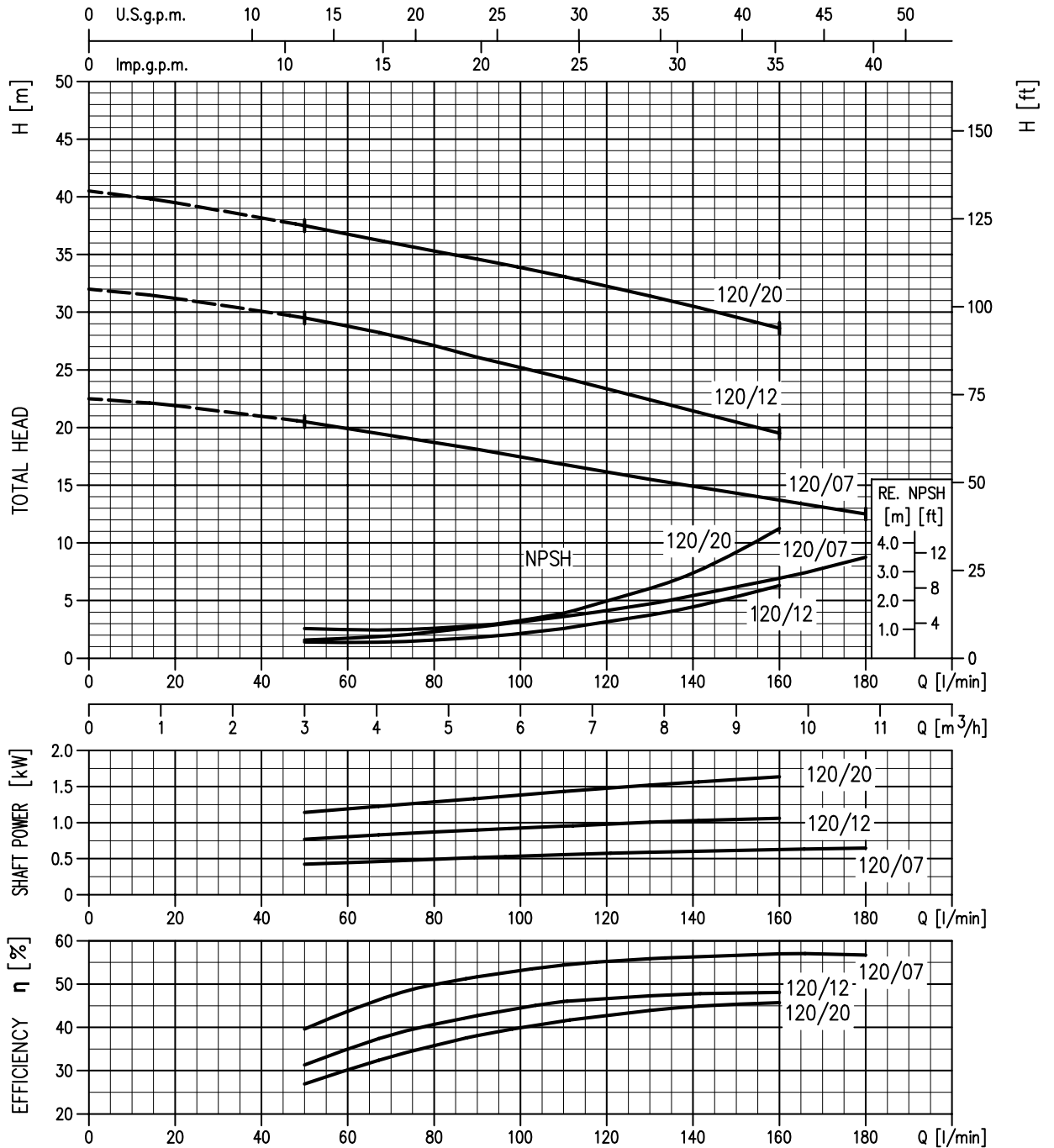

Rotation speed:  $\approx 2800 \text{ min}^{-1}$   
 Test fluid: clean water at 20°C  
 Applicable standard of test: ISO 9906 grade 2

CD 200 PERFORMANCHE CURVES

50 Hz

CD 200/12 (0.09 kW) Impeller diameter = 132  
 CD 200/20 (1.50 kW) Impeller diameter = 157  
 CD 200/25 (1.80 kW) Impeller diameter = 176

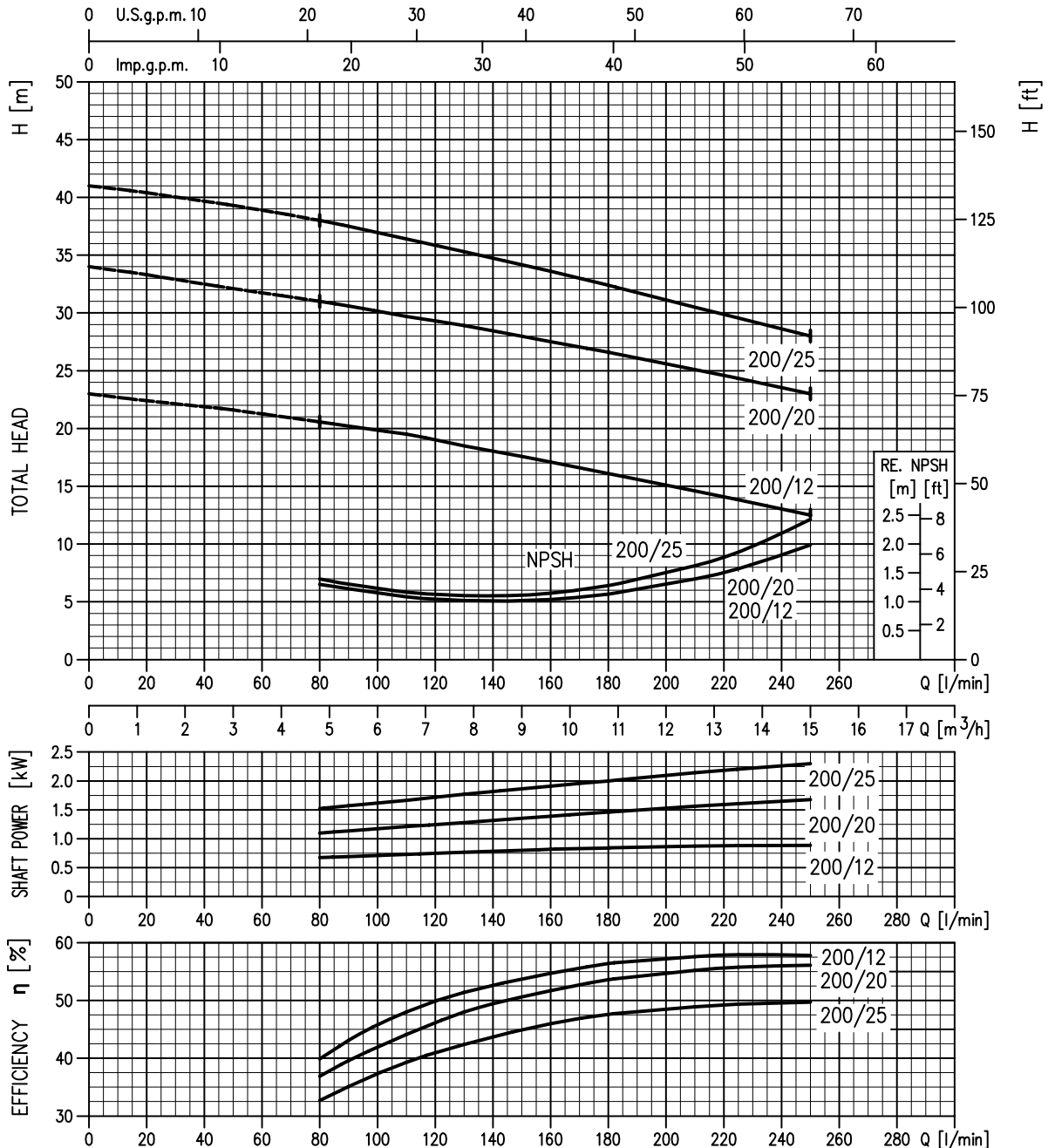

Rotation speed:  $\approx 2800 \text{ min}^{-1}$   
 Test fluid: clean water at 20°C  
 Applicable standard of test: ISO 9906 grade 2



## SECTIONAL VIEW

50 Hz

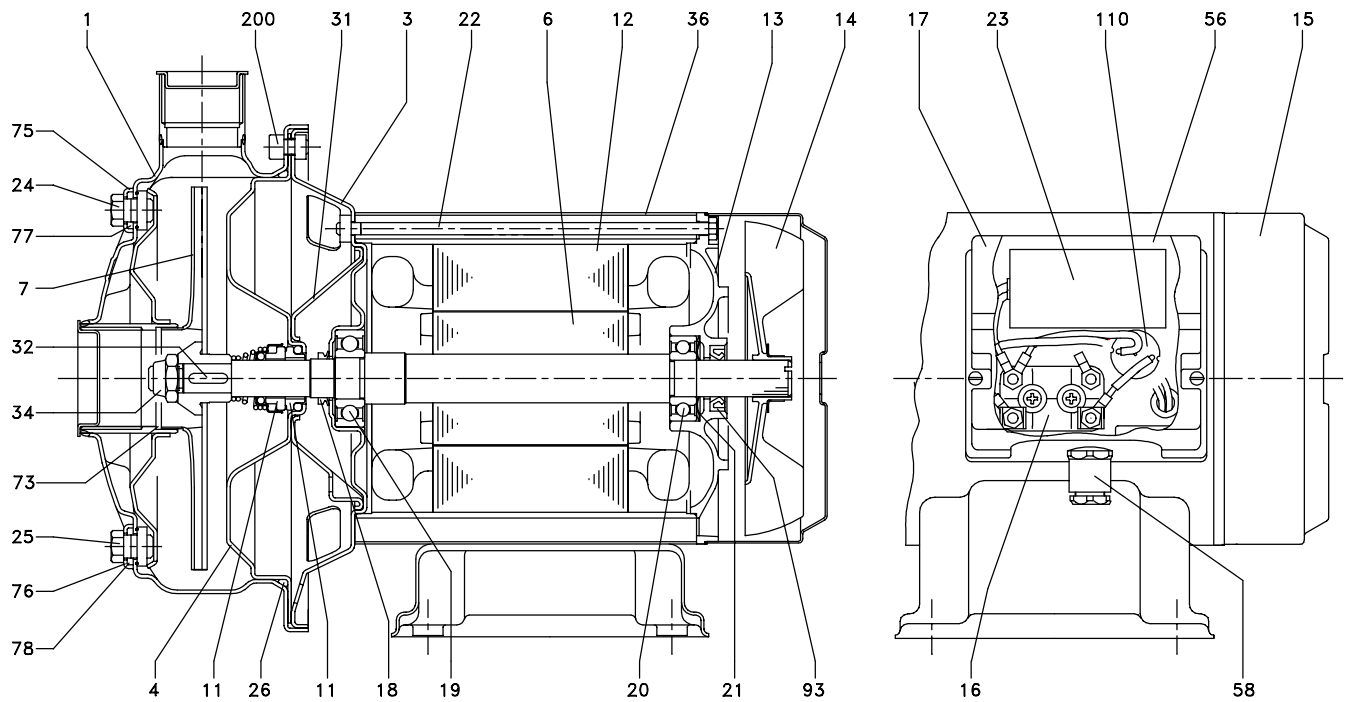

N°	PART NAME	MATERIAL	Q.TY	N°	PART NAME	MATERIAL	Q.TY
1	Casing	AISI 304	1	24	Priming plug	AISI 303	1
3	Motor bracket	AISI 304	1	25	Drain plug	AISI 303	1
4	Casing cover	AISI 304	1	26	O-ring [2]	NBR	1
6	Shaft with rotor	AISI 303 (Part in contact with liquid)	1	31	Thrust flange	AISI 304	1
7	Impeller	AISI 304	1	32	Key	AISI 304	1
11	Mechanical seal [2]	Ceramic/Carbon/NBR	1	34	Impeller nut	AISI 304	1
12	Motor frame with stator	-	1	36	External motor casing	AISI 304	1
13	Motor cover	Aluminium	1	56	Box gasket	NBR	1
14	Fan	Polypropilene	1	58	Cable entry	-	1
15	Fan cover	AISI 304	1	73	Casing ring [3]	AISI 304	1
16	Terminal box	-	1	75	Washer	AISI 304	1
17	Terminal box cover	Polyamide	1	76	Washer	AISI 304	1
18	"V" seal ring	NBR	1	77	O-ring [2]	NBR	1
19	Pump side ball bearing	-	1	78	O-ring [2]	NBR	1
20	Fan side ball bearing	-	1	93	Lip seal	NBR	1
21	Adjusting ring	Steel C70	1	110	Protector [1]	-	1
22	Tie rod	Fe 42 Zinked	4	200	Screw	Stainless steel A2 UNI7323	8
23	Capacitor [1]	-	1	-	-	-	-

[1] Only for single phase

[2] FPM for CDH and CDHS

[3] NBR for :CD 70/05, 70/07, 90/10

FPM for CDH 70/05, 70/07, 90/10 and CDHS 70/05, 70/07, 90/10

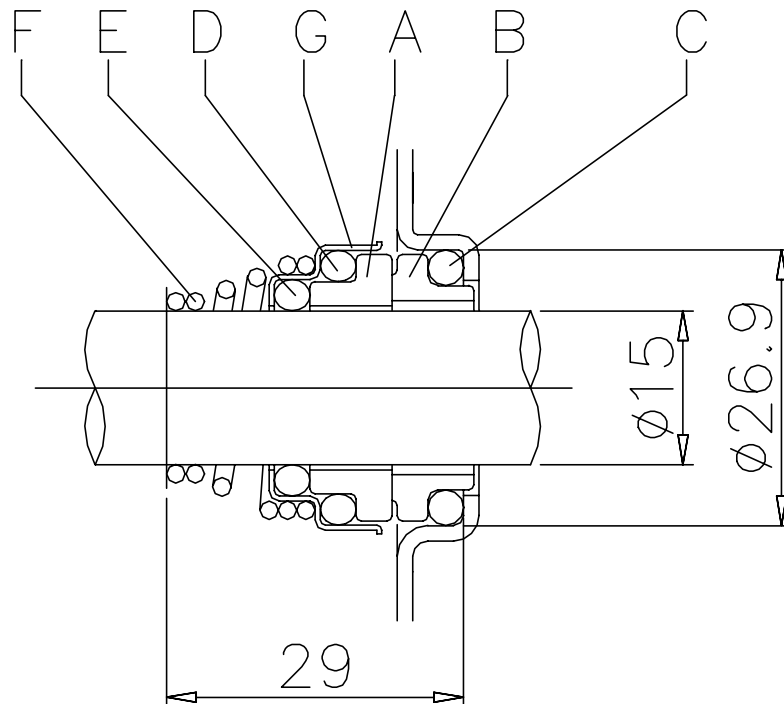

REF	PART NAME	MATERIAL		
		Standard version (CD)	Optional (CDH) (CDHS)	
A	Rotary seal ring	Ceramic	Ceramic	Silicon carbide
B	Stationary seal ring	Carbon graphite	Carbon graphite	Silicon carbide
C	O Ring	NBR	FPM	FPM
D	O Ring	NBR	FPM	FPM
E	O Ring	NBR	FPM	FPM
F	Self driving spring	AISI 316	AISI 316	AISI 316
G	Frame	AISI 304	AISI 304	AISI 316

FOR MOTORS WITH LOCKED ROTOR CURRENT  
UP TO 25 [A]  
INTERNAL MOTORPROTECTOR

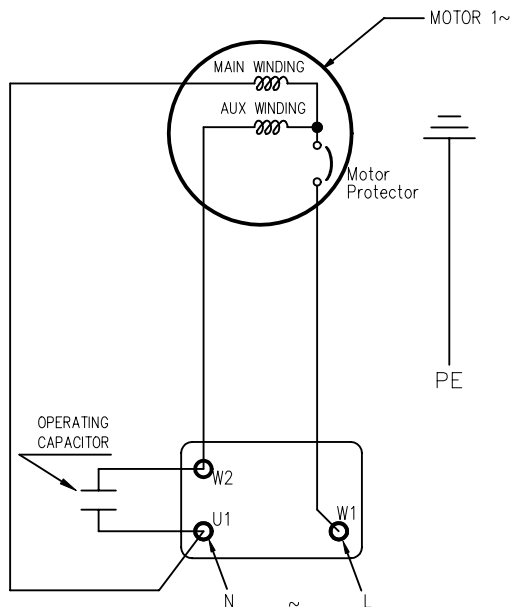

FOR MOTORS WITH LOCKED ROTOR CURRENT  
OVER 25 [A]  
EXTERNAL MOTORPROTECTOR

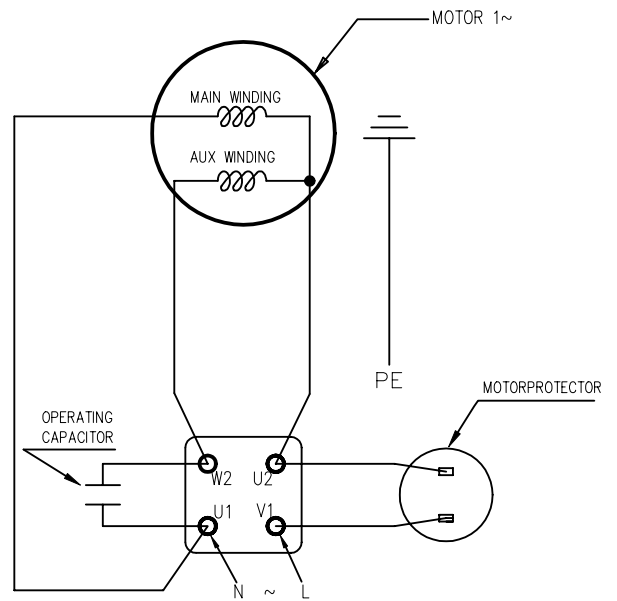

PUMP	MOTORPROTECTOR	
	INTERNAL	EXTERNAL
CDM 70/05	X	
CDM 70/07	X	
CDM 70/12		
CDM 90/10	X	
CDM 120/07	X	
CDM 120/12	X	
CDM 120/20		X
CDM 200/12	X	
CDM 200/20		X

STAR CONNECTION (400 V)

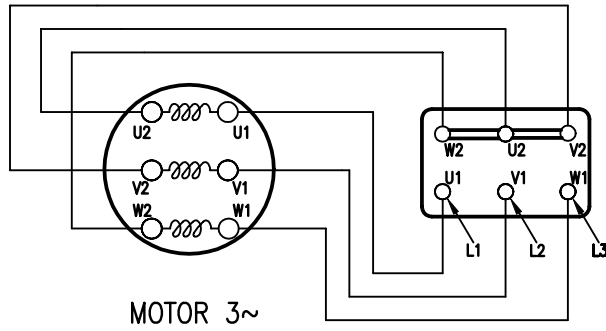

DELTA CONNECTION (230 V)

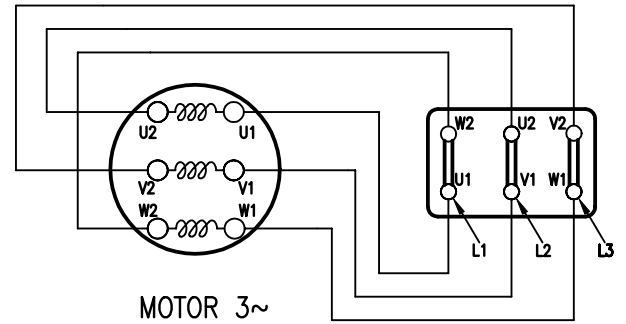

## DIMENSIONS

50 Hz

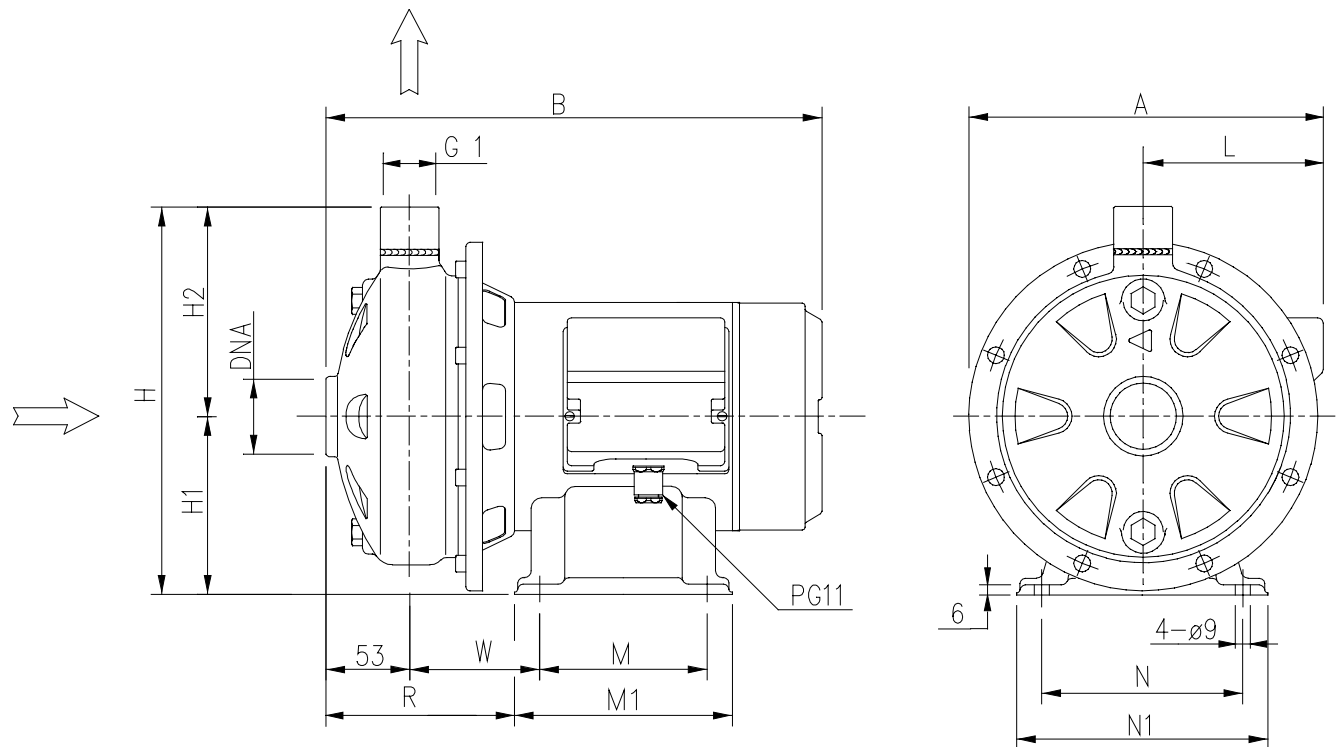

Pump type CDM-CD	Dimensions [mm]																
	A		B	H	H1	H2	L		M		M1		N	N1	R	W	DNA
	1	2					1	2	1	2	1	2					
70/05	206	210	298	229	106	123	102	106	100	100	130	130	120	150	101	63	G1 1/4
70/07	206	210	298	229	106	123	102	106	100	100	130	130	120	150	101	63	G1 1/4
70/12	218	218	328	250	118	132	102	102	100	100	130	130	120	150	131	93	G1 1/4
90/10	206	210	328	229	106	123	102	106	100	100	130	130	120	150	131	93	G1 1/4
120/07	206	210	298	229	106	123	102	106	100	100	130	130	120	150	101	63	G1 1/4
120/12	206	206	328	229	106	123	102	102	100	100	130	130	120	150	101	63	G1 1/4
120/20	226	226	356	250	118	132	110	110	100	100	130	130	120	150	131	93	G1 1/4
200/12	206	206	328	229	106	123	102	102	100	100	130	130	120	150	131	93	G1 1/2
200/20	214	214	356	229	106	123	110	110	120	120	150	150	140	170	133	95	G1 1/2
200/25	226	-	366	250	118	132	-	110	120	-	150	-	140	170	138	100	G1 1/2

- [1] Only for three phase
- [2] Only for single phase

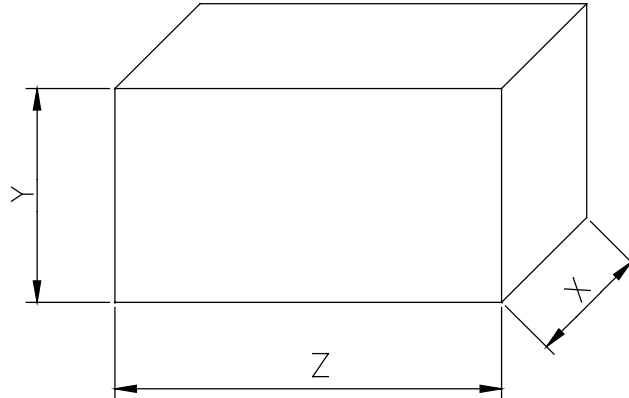

Type pumps		PACKING [mm]			WEIGHT [kg]	
Single Phase	Three Phase	X	Y	Z	Single Phase	Three Phase
CDM 70/05	CD 70/05	250	262	365	9.4	9.4
CDM 70/07	CD 70/07	250	262	365	10.8	10.8
CDM 70/12	CD 70/12	250	260	360	14.1	14.1
CDM 90/10	CD 90/10	250	265	365	12.4	12.4
CDM 120/07	CD 120/07	250	270	365	10.7	10.7
CDM 120/12	CD 120/12	250	270	360	13.3	13.3
CDM 120/20	CD 120/20	250	275	365	17.3	17.3
CDM 200/12	CD 200/12	250	270	365	12.8	12.7
CDM 200/20	CD 200/20	250	265	367	16.7	16.7
-	CD 200/25	250	285	367	-	17.4

## TECHNICAL DATA

50 Hz

Type pumps		Power		Locked rotor current			Capacitor		Input [kW]		Full load current [A]		
Single Phase 230 V 50 Hz	Three Phase 230/400 V 50 Hz	kW	HP	Single Phase 230 V 50 Hz	Three Phase 230 V 50 Hz	400 V 50 Hz	Single Phase [μF]	Vc [V]	Single Phase	Three Phase	Single Phase	Three 230 V	Phase 400 V
CDM 70/05	CD 70/05	0.37	0.5	10.1	10.7	6.15	12.5	450	0.71	0.68	3.1	2.4	1.4
CDM 70/07	CD 70/07	0.55	0.75	16.1	16.8	9.7	16	450	1.0	1.0	4.6	3.5	2.0
CDM 70/12	CD 70/12	0.9	1.2	24.5	28.2	16.3	31.5	450	1.5	1.4	6.5	5.0	2.9
CDM 90/10	CD 90/10	0.75	1	22.7	24.1	13.9	20	450	1.2	1.1	5.6	4.0	2.3
CDM 120/07	CD 120/07	0.55	0.75	16.1	16.8	9.7	16	450	1.0	1.0	4.6	3.2	1.85
CDM 120/12	CD 120/12	0.9	1.2	25	28.2	16.3	31.5	450	1.6	1.4	6.9	4.9	2.8
CDM 120/20	CD 120/20	1.5	2	43	41.6	24	40	450	2.1	2.1	9.7	7.0	4.0
CDM 200/12	CD 200/12	0.9	1.2	25	28.2	16.3	31.5	450	1.4	1.3	6.3	4.7	2.7
CDM 200/20	CD 200/20	1.5	2	43	41.6	24	40	450	2.3	2.1	9.8	7.0	4.0
-	CD 200/25	1.85	2.5	-	46.8	27	-	-	-	2.8	-	8.6	5.0

Type pumps		Ball Bearing	
Single Phase 230 V 50 Hz	Three Phase 230-400 V 50 Hz	Pump side	Fan side
CDM 70/05	CD 70/05	6203 ZZ	6202 ZZ
CDM 70/07	CD 70/07	6203 ZZ	6202 ZZ
CDM 70/12	CD 70/12	6203 ZZ	6202 ZZ
CDM 90/10	CD 90/10	6203 ZZ	6202 ZZ
CDM 120/07	CD 120/07	6203 ZZ	6202 ZZ
CDM 120/12	CD 120/12	6203 ZZ	6202 ZZ
CDM 120/20	CD 120/20	6204 ZZ	6203 ZZ
CDM 200/12	CD 200/12	6203 ZZ	6202 ZZ
CDM 200/20	CD 200/20	6204 ZZ	6203 ZZ
-	CD 200/25	6204 ZZ	6203 ZZ