

2025

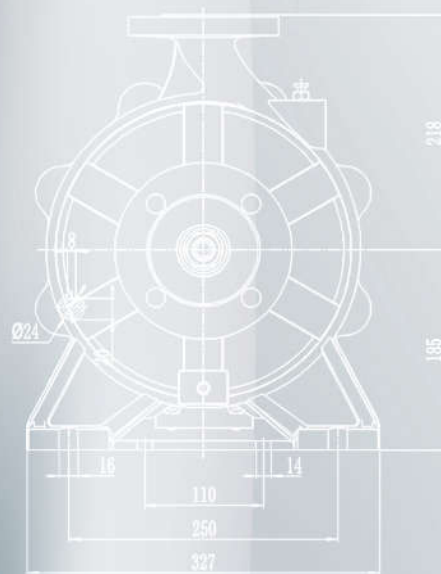

MARO

water pumps

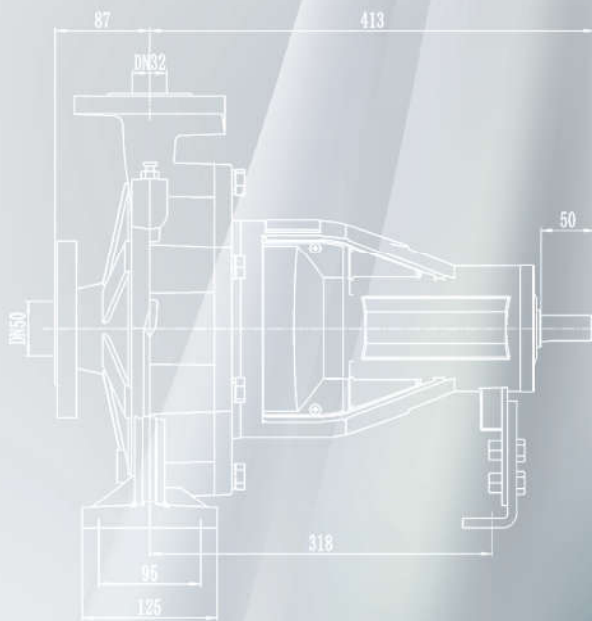



CM



CM
30-160kW

DESCRIPTION

- ◆ New EN733 standard centrifugal pump
- ◆ Original design by MARO
- ◆ Both square motor & round motor available
- ◆ High efficient motor, with protection IP55 class F
- ◆ Pump case with anti-corrosive coating
- ◆ Galvanized counter flange with bolts, nuts and gaskets
- ◆ Quality NSK bearing, wear resistance mechanical seal

APPLICATIONS

Suitable for use with clean water and liquids that are not chemically aggressive towards the materials from which the pump is made.

The EN733 centrifugal pumps are recommended for use in water supply, cleaning sets, pressure boosting, firefighting sets, irrigation, industrial applications, water circulation in climatisation sets, agri cultural.



CM red color apply for Fire protection system

MODEL CODE

For example

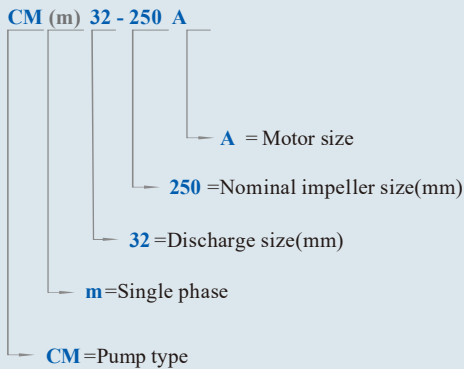

USING LIMITS

- ◆ Liquid temperature between -10°C and +120°C
- ◆ Ambient temperature between -10°C and +50°C
- ◆ Max. working pressure 16 bar
- ◆ Continuous service S1

TECHNICAL SHEET

Model	CM	
Capacity	0-400	m ³ /h
Head	0-151	m
DN	32-125	mm
Speed	2900	rpm
T max	120	°C
Power	0.75-160	kW
Voltage	220/380/400/440	V
HZ	50	
Class	Class F	
IP	IP 55	
Duty	S1 continuous	
Casing	Grey Cast iron	
Impeller	Cast iron/AISI 304/Brass	
Shaft	45# steel/AISI304	
Shaft seal	Mechanical Seal	
Bearing	Grease lubrication rolling bearing	

CM **n ≈ 2900 rpm**
Close coupled centrifugal pump

TECHNICAL DATA

50 Hz n=2900 1/min

MODEL	DN mm	Power kw hp		Q=DELIVERY																	
				us gpm	0	26	40	66	79	106	119	159	185	211	238	317	370	396	476	529	608
				l/min	0	100	150	250	300	400	450	600	700	800	900	1200	1400	1500	1800	2000	2300
				m³/h	0	6	9	15	18	24	27	36	42	48	54	72	84	90	108	120	138
				H=Head (m)																	
CM 32-125B	50x32	0.75	1	17.5	16.7	15	12	9	-	-	-	-	-	-	-	-	-	-	-	-	-
CM 32-125A	50x32	1.1	1.5	22	21	19.7	16.5	14.5	9	-	-	-	-	-	-	-	-	-	-	-	-
CM 32-160C	50x32	1.5	2	25.4	23.7	22.5	18.5	15.8	-	-	-	-	-	-	-	-	-	-	-	-	-
CM 32-160B	50x32	2.2	3	31	29.6	28.5	24.5	22	15	-	-	-	-	-	-	-	-	-	-	-	-
CM 32-160A	50x32	3	4	35	34.3	32.5	28	25.5	19	15	-	-	-	-	-	-	-	-	-	-	-
CM 32-200D	50x32	3	4	44.2	42	39.8	35.2	32.2	24.6	19.8	-	-	-	-	-	-	-	-	-	-	-
CM 32-200C	50x32	4	5.5	54.5	52	50	45.5	42.3	35	30.3	-	-	-	-	-	-	-	-	-	-	-
CM 32-200B	50x32	5.5	7.5	60	59.5	59	55	50.2	34.5	-	-	-	-	-	-	-	-	-	-	-	-
CM 32-200A	50x32	7.5	10	69.5	69	68.5	66	63	53	-	-	-	-	-	-	-	-	-	-	-	-
CM 32-250C	50x32	9.2	12.5	75	75	74.5	72	69	59	-	-	-	-	-	-	-	-	-	-	-	-
CM 32-250B	50x32	11	15	90	89.5	88	82	78	66	-	-	-	-	-	-	-	-	-	-	-	-
CM 32-250A	50x32	15	20	97	96.5	96	90	86	73	-	-	-	-	-	-	-	-	-	-	-	-
CM 32-250BD	50x32	5.5	7.5	79.5	74.7	71.8	63	56	37.5	-	-	-	-	-	-	-	-	-	-	-	-
CM 32-250AD	50x32	7.5	10	95	93	91	83	76	57.8	-	-	-	-	-	-	-	-	-	-	-	-
CM 40-125C	65x40	1.1	1.5	14.7	-	-	-	13	11.5	10.1	5.8	-	-	-	-	-	-	-	-	-	-
CM 40-125B	65x40	1.5	2	18.1	-	-	-	17	15	13.9	10	6	-	-	-	-	-	-	-	-	-
CM 40-125A	65x40	2.2	3	24.5	-	-	-	23.2	21.5	20.2	16	13	8.3	-	-	-	-	-	-	-	-
CM 40-160B	65x40	3	4	31.8	-	-	-	29.5	27.5	26.3	21.5	17.5	-	-	-	-	-	-	-	-	-
CM 40-160A	65x40	4	5.5	38	-	-	-	36	34	33	28.5	25	20.1	-	-	-	-	-	-	-	-
CM 40-200B	65x40	5.5	7.5	46	-	-	-	43.8	41.3	40.1	35	30	-	-	-	-	-	-	-	-	-
CM 40-200A	65x40	7.5	10	57	-	-	-	53.6	51.5	50	45	41	36.5	-	-	-	-	-	-	-	-
CM 40-250C	65x40	9.2	12.5	64	-	-	-	59	56.5	55	49.5	45	39.8	-	-	-	-	-	-	-	-
CM 40-250B	65x40	11	15	72	-	-	-	67.5	65	63.5	57.5	52.2	47	-	-	-	-	-	-	-	-
CM 40-250A	65x40	15	20	84.5	-	-	-	79.3	77.3	75.2	70	66	61	-	-	-	-	-	-	-	-
CM 40-250A1	65x40	18.5	25	90	-	-	-	85.5	82.8	80.7	75.8	70.5	66.5	-	-	-	-	-	-	-	-
CM 50-125C	65x50	2.2	3	17	-	-	-	-	-	-	15.4	14	12.8	11.5	6.5	-	-	-	-	-	-
CM 50-125B	65x50	3	4	20	-	-	-	-	-	-	18.8	18	17	15.6	11	-	-	-	-	-	-
CM 50-125A	65x50	4	5.5	24	-	-	-	-	-	-	23.1	23	21.5	20.3	15.8	11.8	-	-	-	-	-
CM 50-160B	65x50	5.5	7.5	32	-	-	-	-	-	-	30.6	30	28	26.6	20.5	14.8	-	-	-	-	-
CM 50-160A	65x50	7.5	10	40	-	-	-	-	-	-	38	37	36	34.4	29	24	21	-	-	-	-
CM 50-200C	65x50	9.2	12.5	50.5	-	-	-	-	-	-	46.8	45	43	40.9	32.5	26.7	-	-	-	-	-
CM 50-200B	65x50	11	15	57.5	-	-	-	-	-	-	53.5	52	50	47.5	40	34	29	-	-	-	-
CM 50-200A	65x50	15	20	62	-	-	-	-	-	-	58	56.5	54.5	52	44.5	39	35.5	-	-	-	-
CM 50-250C	65x50	15	20	68.5	-	-	-	-	-	-	64	63	61.5	59	50	41	-	-	-	-	-
CM 50-250B	65x50	18.5	25	79	-	-	-	-	-	-	75.8	74.8	74	71.5	63.5	55.5	47	-	-	-	-
CM 50-250A	65x50	22	30	89.5	-	-	-	-	-	-	86	85.3	84	81.5	73.5	63.5	57	-	-	-	-
CM 65-125C	80x65	4	5.5	19	-	-	-	-	-	-	-	-	17.3	16.8	14.5	13	11.8	-	-	-	-
CM 65-125B	80x65	5.5	7.5	23	-	-	-	-	-	-	-	-	21.3	20.9	19	17.5	16.7	13.7	-	-	-
CM 65-125A	80x65	7.5	10	27	-	-	-	-	-	-	-	-	26	25.6	24.5	23	22.5	20	18	-	-
CM 65-160C	80x65	9.2	12.5	33	-	-	-	-	-	-	-	-	-	31.5	30	28	27.1	24	21.5	-	-
CM 65-160B	80x65	11	15	36	-	-	-	-	-	-	-	-	-	34.5	33	31.5	30.8	28	25.5	-	-
CM 65-160A	80x65	15	20	42	-	-	-	-	-	-	-	-	-	41	40	38.5	37.8	35	33	29.5	-
CM 65-200C	80x65	15	20	45	-	-	-	-	-	-	-	-	-	45.5	43	41	40.2	36.5	34	-	-
CM 65-200B	80x65	18.5	25	52	-	-	-	-	-	-	-	-	-	52.3	51	49	48.2	44.5	42	-	-
CM 65-200A	80x65	22	30	59	-	-	-	-	-	-	-	-	-	59.5	58	56	55	52	49.5	44.5	-
CM 65-250C	80x65	22	30	64.8	-	-	-	-	-	-	-	-	-	64.7	62	60	58.5	53	50	-	-
CM 65-250B	80x65	30	40	80	-	-	-	-	-	-	-	-	-	79.8	77.5	75.5	74.5	70	66	58	-
CM 65-250A	80x65	37	50	92	-	-	-	-	-	-	-	-	-	90.5	88.5	87	85	80.5	78	68	-

TECHNICAL DATA

50 Hz n=2900 1/min

MODEL	DN mm	Power kw hp		Q=DELIVERY														
				us	264	396	529	634	Q=DELIVERY		925	969	1057	1233	1322	1586	1762	
				gpm	0	1000	1500	2000	2400	3000	3333	3500	3667	4000	4667	5000	6000	6667
				l/min	0	60	90	120	144	180	200	210	220	240	280	300	360	400
				H=Head (m)														
CM 65-315D	80x65	45	60	102	98	94.5	90	83	-	-	-	-	-	-	-	-	-	
CM 65-315C	80x65	55	75	122	120	114.5	110	100	76	-	-	-	-	-	-	-	-	
CM 65-315B	80x65	75	100	141	141	134.5	130	120	96	78	65.5	-	-	-	-	-	-	
CM 65-315A	80x65	90	125	151	150	144.5	140	130	106	88	75.5	-	-	-	-	-	-	
CM 80-125C	100x80	4	5.5	17	15	12.3	7.5	-	-	-	-	-	-	-	-	-	-	
CM 80-125B	100x80	5.5	7.5	21	19.6	17.4	13.4	9.5	-	-	-	-	-	-	-	-	-	
CM 80-125A	100x80	7.5	10	26	24.8	23	19.5	16.5	-	-	-	-	-	-	-	-	-	
CM 80-160D	100x80	11	15	28	27	27.3	24.5	21.1	16	-	-	-	-	-	-	-	-	
CM 80-160C	100x80	15	20	34	32.6	32.5	30.2	27	22.1	18.5	16.7	-	-	-	-	-	-	
CM 80-160B	100x80	18.5	25	39	38.5	38	36.7	33.6	28.8	25.3	23.5	-	-	-	-	-	-	
CM 80-160A	100x80	22	30	44	43.5	43	41.7	38.6	33.8	30.3	28.5	-	-	-	-	-	-	
CM 80-200C	100x80	22	30	48	47.7	47.5	43.5	39.2	32.5	27.2	24.5	-	-	-	-	-	-	
CM 80-200B	100x80	30	40	60	59.7	59.5	57	53.1	47	42.7	40.5	-	-	-	-	-	-	
CM 80-200A	100x80	37	50	71.5	70.9	70.5	65.5	59.3	51	43.2	38.5	-	-	-	-	-	-	
CM 80-250B	100x80	45	60	88	86.7	86	83.6	78.5	70.5	60	51	-	-	-	-	-	-	
CM 80-250A	100x80	55	75	94.5	94.5	94.5	91.8	87	79.5	72.1	68.3	-	-	-	-	-	-	
CM 80-315D	100x80	45	60	85	84	82.6	82	78	68.3	61	56	-	-	-	-	-	-	
CM 80-315C	100x80	55	75	98	97	95.6	95	91	81.3	74	69	-	-	-	-	-	-	
CM 80-315B	100x80	75	100	124	123	121.6	121	117	107.3	100	95	90	80.8	-	-	-	-	
CM 80-315A	100x80	90	125	144	143	141.6	141	137	127.3	120	115	110	100.8	-	-	-	-	
CM 100-160/150	125x100	15	20	35	33.5	32.5	30	27.8	24.5	21.5	20	18.3	15	-	-	-	-	
CM 100-160/185	125x100	18.5	25	38.5	37.5	36.5	34.3	32.2	29	25.7	24	22	18	-	-	-	-	
CM 100-160/220	125x100	22	30	43	41	40	37.6	35.2	31.5	28.5	27	25.3	22	-	-	-	-	
CM 100-200/220	125x100	22	30	38.5	36.7	35.7	33.8	31.7	28.5	26.8	26	25	22.9	16.3	13	-	-	
CM 100-200/300	125x100	30	40	44.5	42.5	42	40.2	38.8	36.7	34.2	33	31.7	29	21.7	18	-	-	
CM 100-200/370	125x100	37	50	55	53	51	50.6	49.2	47	45	44	42.8	40.5	32.8	29	-	-	
CM 100-250/450	125x100	45	60	65	65	64	63	61	58	56	55	53.3	50	39	33.5	-	-	
CM 100-250/550	125x100	55	75	77	76	75.5	75	73.8	72	71.7	71.5	70.7	69	62.3	59	-	-	
CM 100-250/750	125x100	75	100	91	91	90.5	89.7	88	85.5	84	83.3	81.5	78	71.7	68.5	48	-	
CM 100-250/900	125x100	90	125	100	100	99.5	98.7	97	94.5	93	92.3	90.5	87	80.7	77.5	57	-	
CM 100-315/750	125x100	75	100	80	-	-	78.5	76.7	74	73	72.8	72.5	70.7	68	64	52	-	
CM 100-315/900	125x100	90	125	100	-	-	98.5	96.7	94	93	92.8	92.5	90.7	88	84	72	-	
CM 100-315/1100	125x100	110	150	118	-	-	116.5	114.7	112	111	110.8	110.5	108.7	106	102	90	-	
CM 100-315/1320	125x100	132	180	129	-	-	127.5	125.7	123	122	121.8	121.5	119.7	117	112	101	-	
CM 100-315/1600	125x100	160	220	148	-	-	146.5	144.7	142	141	140.8	140.5	138.7	136	132	120	-	
CM 125-200/450	150x125	45	60	39.8	-	-	39.3	39.2	39	38.9	38.9	38.8	37.5	35	34	28.6	25	
CM 125-200/550	150x125	55	75	50.5	-	-	49.3	49.2	49	48.9	48.9	48.8	47.5	45	44	38.6	35	
CM 125-200/750	150x125	75	100	61.5	-	-	60.3	60.2	60	59.9	59.9	59.8	58.5	56	55	49.6	46	
CM 125-250/550	150x125	55	75	70	-	-	67	66	64	63	62	61	59.5	54	50.5	-	-	
CM 125-250/750	150x125	75	100	80	-	-	76.5	75.5	74	73	72	71.5	70	67	65	56	-	
CM 125-250/900	150x125	90	125	87	-	-	84	82.5	81	79.5	79	78	77	73.5	71.5	65	60	

MATERIAL DESCRIPTION

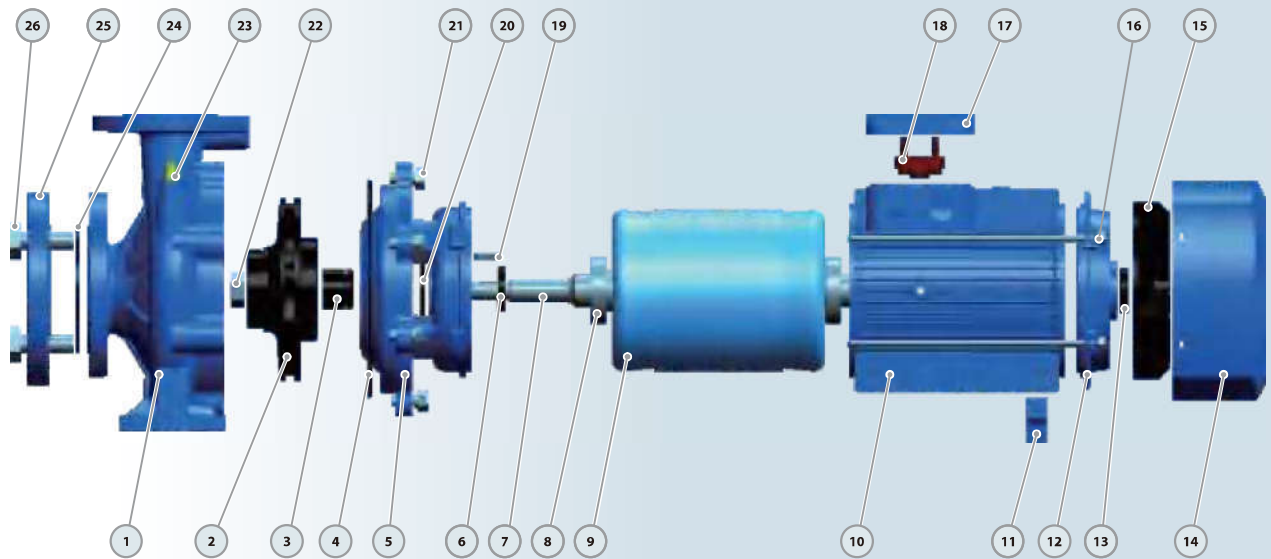

No.	Description	Material	No.	Description	Material	No.	Description	Material
1	Pump Case	Cast iron	10	Motor Case	Aluminum	19	Impeller Key	Iron
2	Impeller	SS304/Cast iron	11	Support Foot	Plastic	20	Water Deflector	Rubber
3	Mechanical Seal	SiC/Carbon/SS304	12	Back Cover	Cast iron	21	Connection Bolt	Steel
4	O-ring	Rubber	13	Reinforced Seal	Rubber	22	Impeller Nut	Galvanized Steel
5	Connection	Cast iron	14	Fan Cover	Aluminum	23	Release Valve	Brass
6	Reinforced Seal	Rubber	15	Fan	Plastic	24	Gasket	Rubber
7	Shaft	SS304/45# Steel	16	Through Bolt	Steel	25	Counter Flange	Galvanized Cast iron
8	Bearing	Ball Bearing	17	Terminal Box	Aluminum	26	Flange Bolt	Steel
9	Wound Stator/Rotor	Silicon Steel/Copper	18	Terminal Board	Plastic			

DIMENSIONS AND WEIGHT

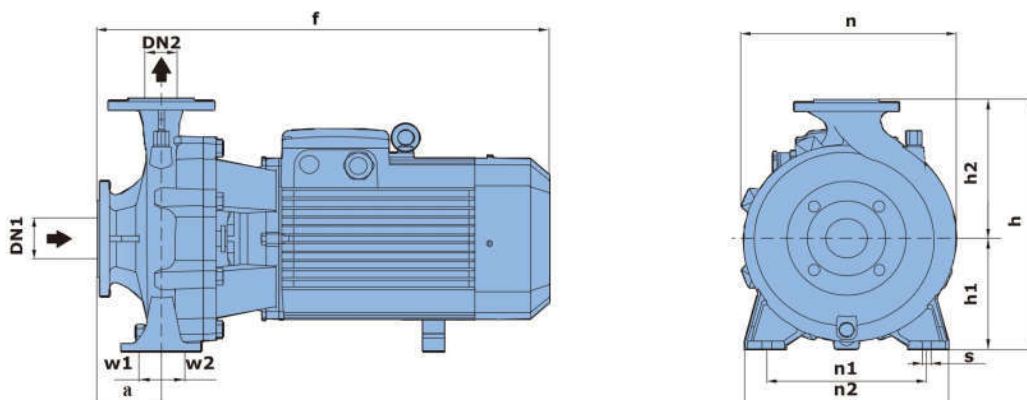

MODEL	DIMENSIONS mm													kg 3~		
	DN1	DN2	a	f	h	h1	h2	n	n1	n2	w1	w2	s			
CM 32-125B	50	32	80	435	255	114	141	202	140	190	35	35	15	24		
CM 32-125A			25													
CM 32-160C			34													
CM 32-160B			39													
CM 32-160A			50													
CM 32-200D			52													
CM 32-200C			53													
CM 32-200B			66													
CM 32-200A			73													
CM 32-250C			80													
CM 32-250B			95													
CM 32-250A			125													
CM 32-250AD-BD	160	610	362	162	200	330	216	280	14	73/80						
CM 40-125C	65	40	82	440	260	116	144	220	160	212	37	37	15	27		
CM 40-125B			29													
CM 40-125A			34													
CM 40-160B			48													
CM 40-160A			50													
CM 40-200A-B			66/73													
CM 40-250C			100													
CM 40-250B			116													
CM 40-250A			146													
CM 40-250A1			155													
CM 50-125C			50	50	102	525	305	135	170	263	190	245	37	37	15	41
CM 50-125B					50											
CM 50-125A	52															
CM 50-160A-B	64/71															
CM 50-200C	90															
CM 50-200B	106															
CM 50-200A	145															
CM 50-250A-B-C	148/153/183															
CM 65-125C	80	65			104	580	345	162	193	275	212	280	49	49	16	56
CM 65-125A-B					68/74											
CM 65-160C					90											
CM 65-160B					106											
CM 65-160A			134													
CM 65-200A-B-C			140/145/185													
CM 80-125C			100	80	117	750	357	163	194	330	212	280	55	55	16	56
CM 80-125A-B					68/74											
CM 80-160D					113											
CM 80-160A-B-C					143/150/183											
CM 100-160/150-185-220			125	100	130	765	435	186	250	345	262	340	55	55	16	143/150/183

DIMENSIONS AND WEIGHT

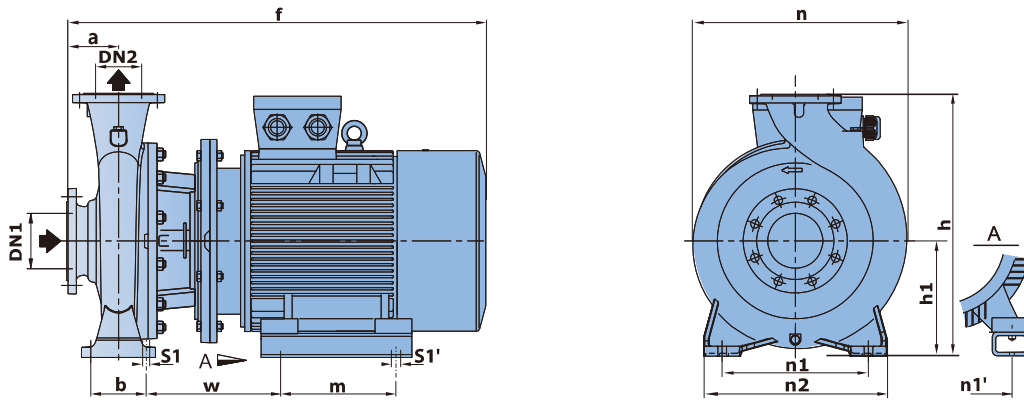

MODEL	DIMENSIONS mm															kg
	DN1	DN2	a	f	h	h1	n	n1	n1'	n2	b	w	m	s1	s1'	
CM 65-250/220	80	65	116	870	420	180	369	280	279	360	120	237	241	18	15	214
CM 65-250/300	80	65	116	990	420	180	369	280	318	360	120	278	305	18	18	265
CM 65-250/370	80	65	116	990	420	180	369	280	318	360	120	278	305	18	18	285
CM 65-315/450	80	65	125	1069	505	225	440	280	356	360	120	324	311	18	18	371
CM 65-315/550	80	65	125	1160	505	225	440	280	406	360	120	373	349	18	24	450
CM 65-315/750	80	65	125	1232	505	225	440	280	457	360	120	395	368	18	24	582
CM 65-315/900	80	65	125	1283	505	225	440	280	457	360	120	395	419	18	24	617
CM 80-200/220	100	80	125	880	460	250	360	280	279	345	95	251	241	14	15	211
CM 80-200/300	100	80	125	950	460	250	360	280	318	345	95	242	305	14	18	262
CM 80-250/370	100	80	125	950	535	250	410	315	318	400	120	229	305	18	18	289
CM 80-250/450	100	80	125	980	535	250	410	315	356	400	120	235	311	18	18	362
CM 80-250/550	100	80	125	1160	535	250	410	315	406	400	120	373	349	18	24	441
CM 80-315/450	100	80	125	1069	565	250	452	315	356	400	120	324	311	18	18	381
CM 80-315/550	100	80	125	1160	565	250	452	315	406	400	120	373	349	18	24	460
CM 80-315/750	100	80	125	1232	565	250	452	315	457	400	120	395	368	18	24	592
CM 80-315/900	100	80	125	1283	565	250	452	315	457	400	120	395	419	18	24	627
CM 100-200/220	125	100	125	910	530	225	422	280	279	360	120	268	241	18	15	216
CM 100-200/300	125	100	125	1025	530	225	422	280	318	360	120	304	305	18	18	267
CM 100-200/370	125	100	125	1025	530	225	422	280	318	360	120	304	305	18	18	287
CM 100-250/450	125	100	140	1000	580	250	450	315	356	400	120	240	311	18	18	366
CM 100-250/550	125	100	140	1180	580	250	450	315	406	400	120	378	349	18	24	445
CM 100-250/750	125	100	140	1250	580	250	450	315	457	400	120	398	368	18	24	577
CM 100-250/900	125	100	140	1300	580	250	422	315	457	400	120	397	419	18	24	612
CM 100-315/750	125	100	140	1262	625	250	480	315	457	400	120	410	368	19	24	591
CM 100-315/900	125	100	140	1313	625	250	480	315	457	400	120	410	419	19	24	626
CM 100-315/1100	125	100	140	1474	625	250	480	315	508	400	120	436	406	19	28	972
CM 100-315/1320	125	100	140	1584	625	250	480	315	508	400	120	436	457	19	28	1087
CM 100-315/1600	125	100	140	1584	625	250	480	315	508	400	120	436	508	19	28	1125
CM 125-200/450	150	125	140	1099	565	250	422	315	356	400	120	339	311	19	18	378
CM 125-200/550	150	125	140	1190	565	250	422	315	406	400	120	388	349	19	24	457
CM 125-200/750	150	125	140	1262	565	250	422	315	457	400	120	410	368	19	24	589
CM 125-250/550	150	125	140	1190	605	250	500	315	406	400	120	388	349	19	24	457
CM 125-250/750	150	125	140	1262	605	250	500	315	457	400	120	410	368	19	24	589
CM 125-250/900	150	125	140	1313	605	250	500	315	457	400	120	410	419	19	24	624

32-125

2900rpm

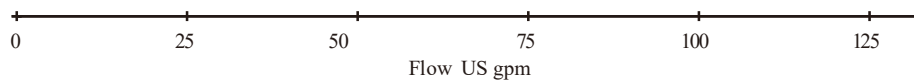
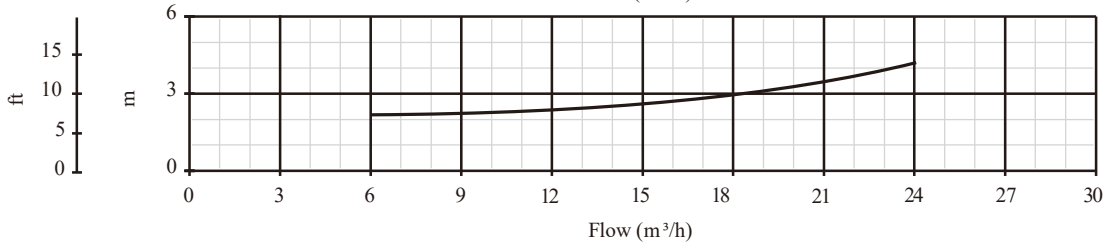
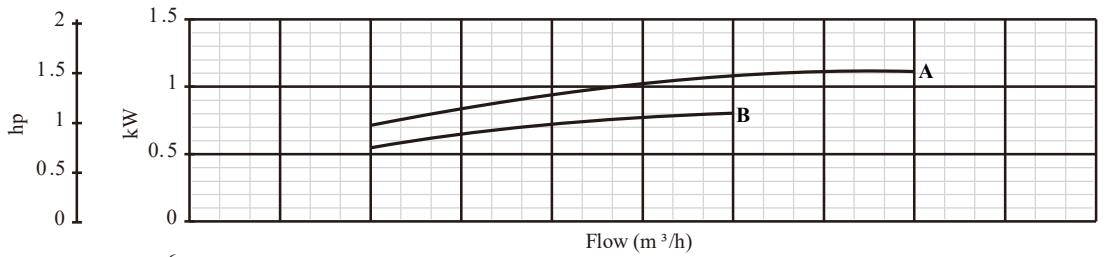
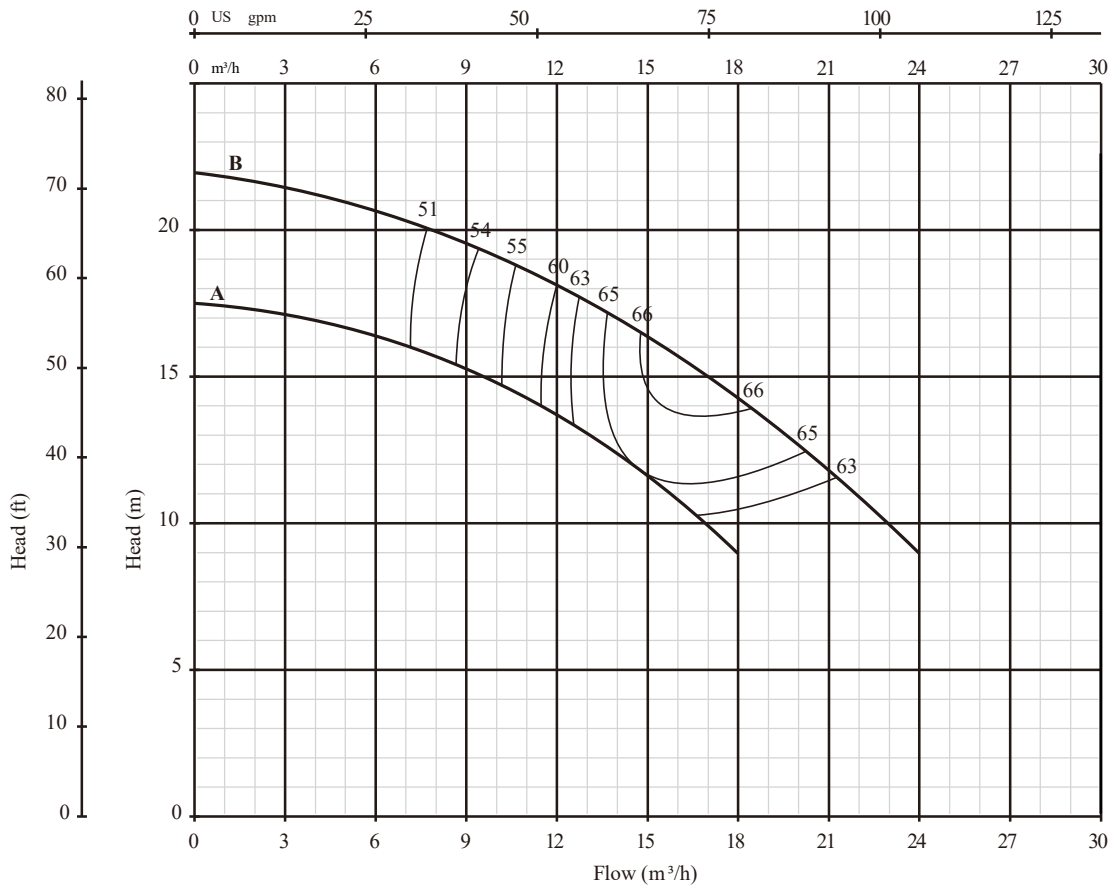

H - Q

P - Q

NPSHr

PERFORMANCE CURVE

32-160

2900rpm

PERFORMANCE CURVE

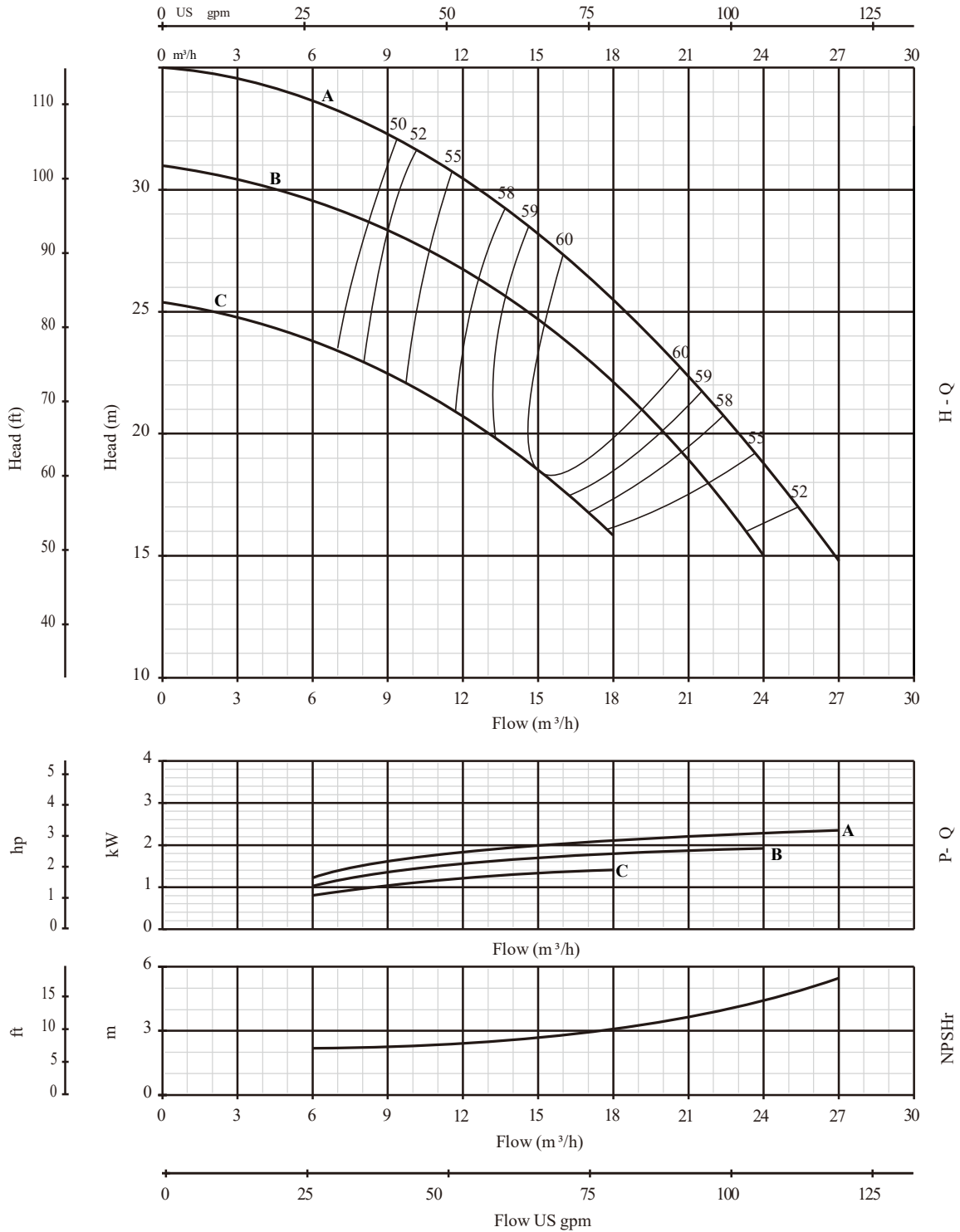

32-200

2900rpm

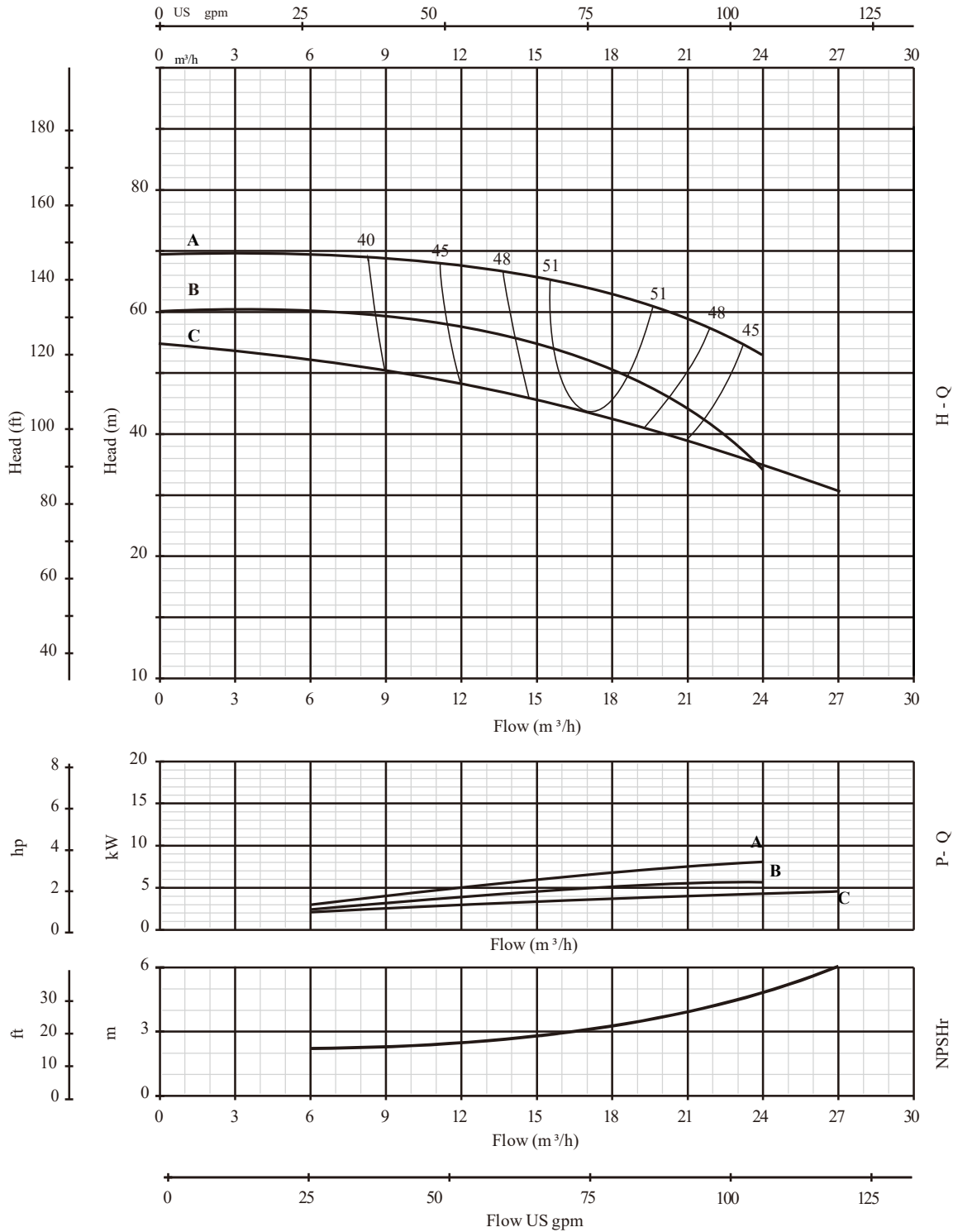

PERFORMANCE CURVE

32-250

2900rpm

PERFORMANCE CURVE

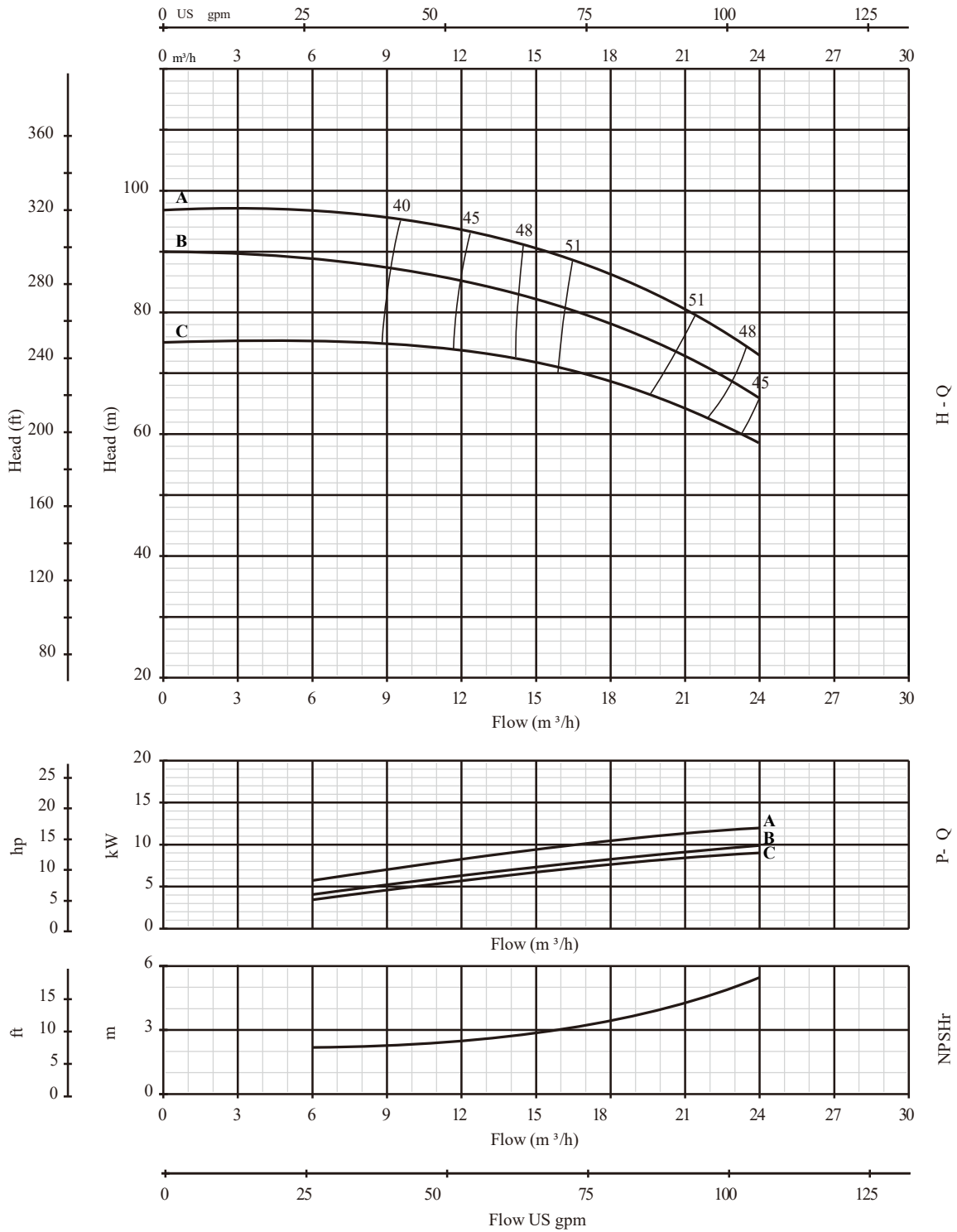

32-250D

2900rpm

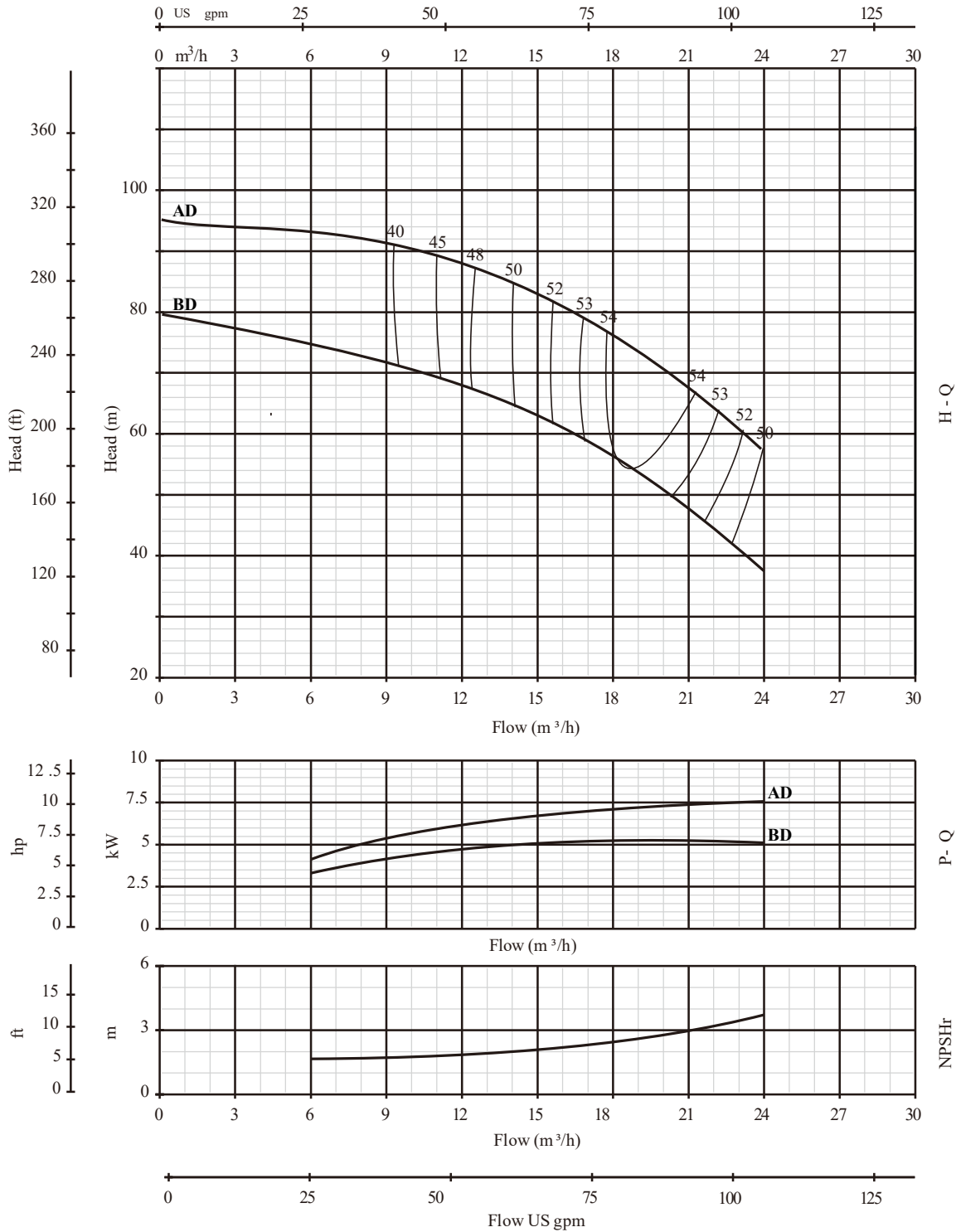

PERFORMANCE CURVE

40-125

2900rpm

PERFORMANCE CURVE

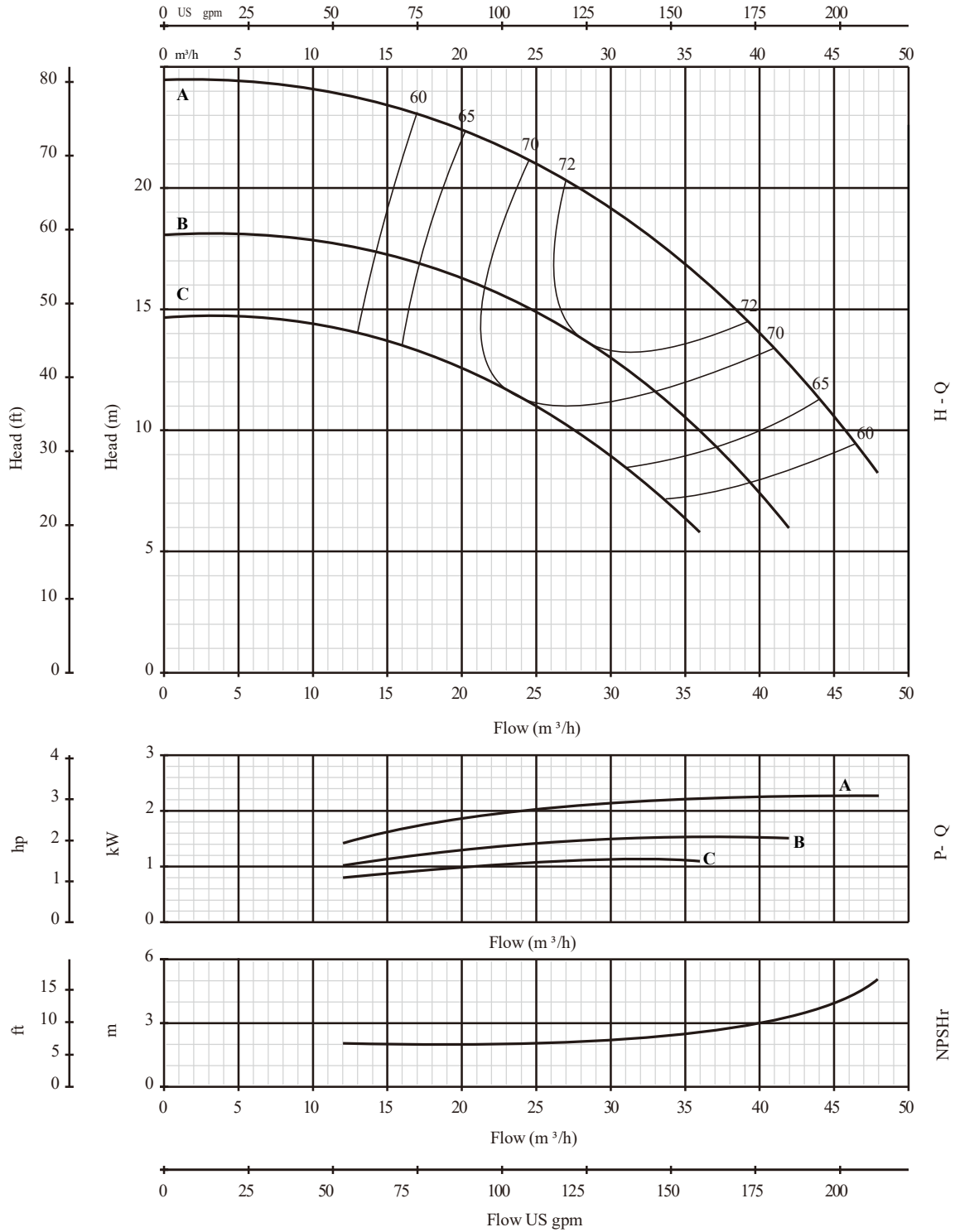

40-200

2900rpm

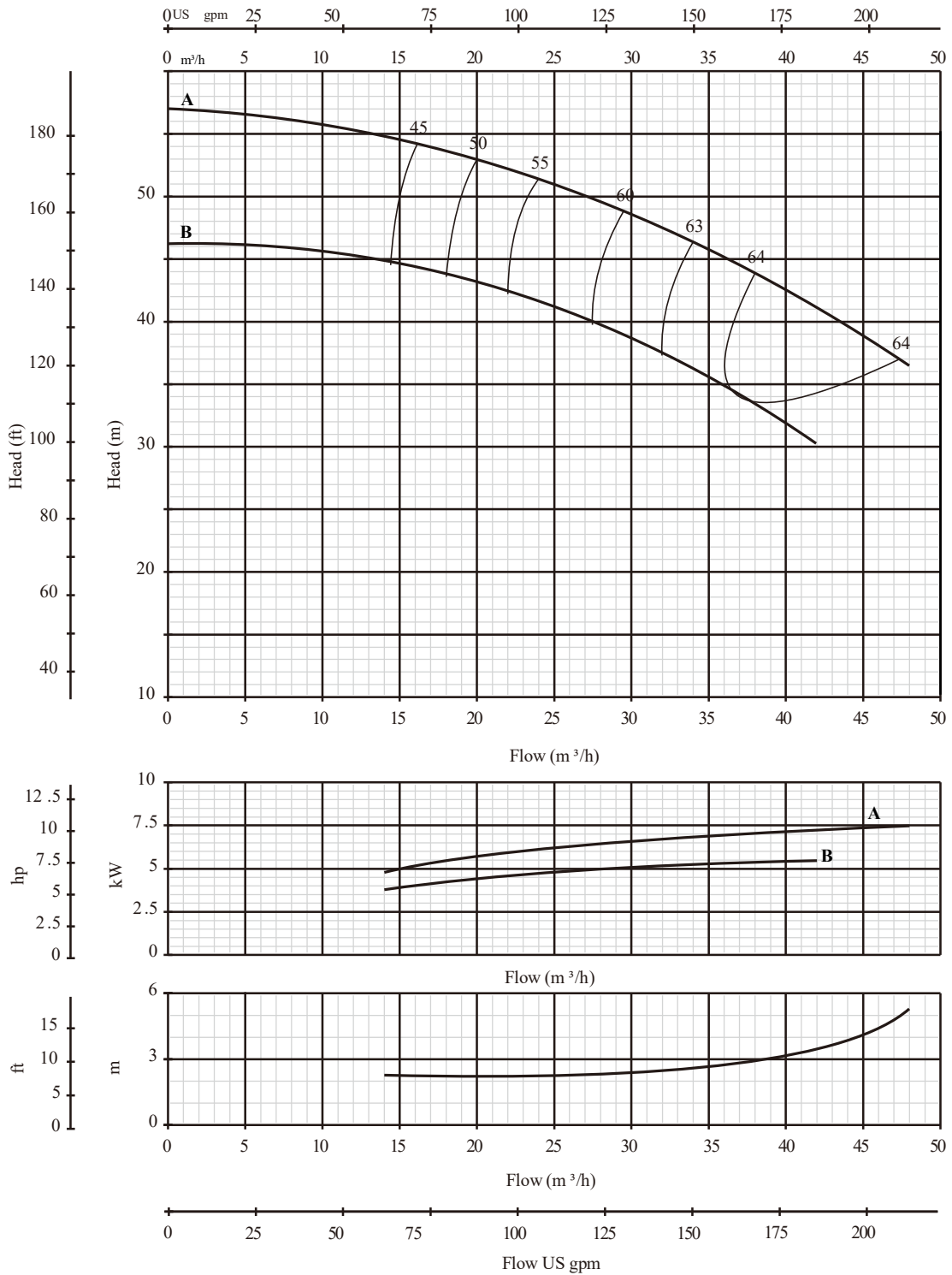

PERFORMANCE CURVE

40-250

2900rpm

PERFORMANCE CURVE

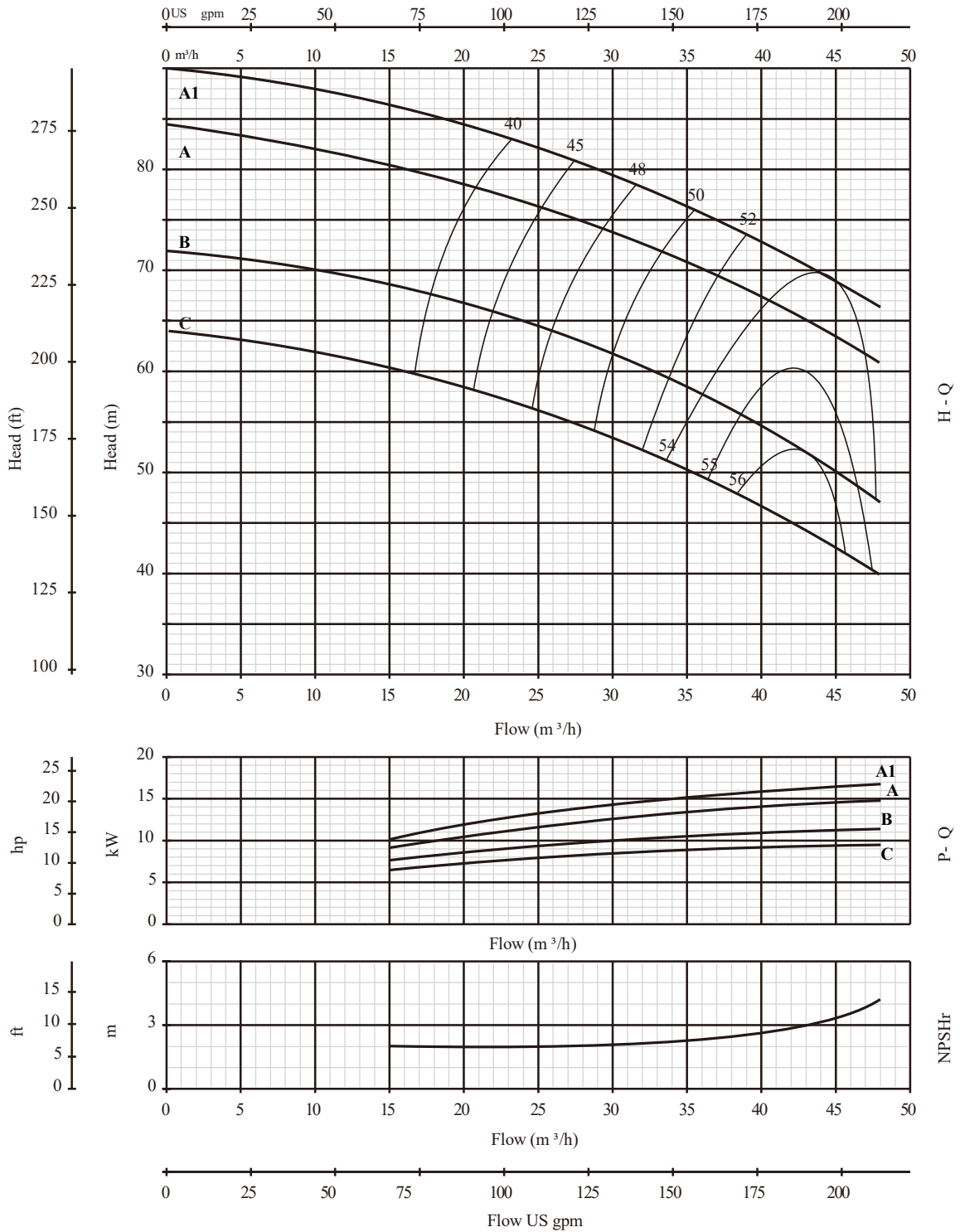

50-125

2900rpm

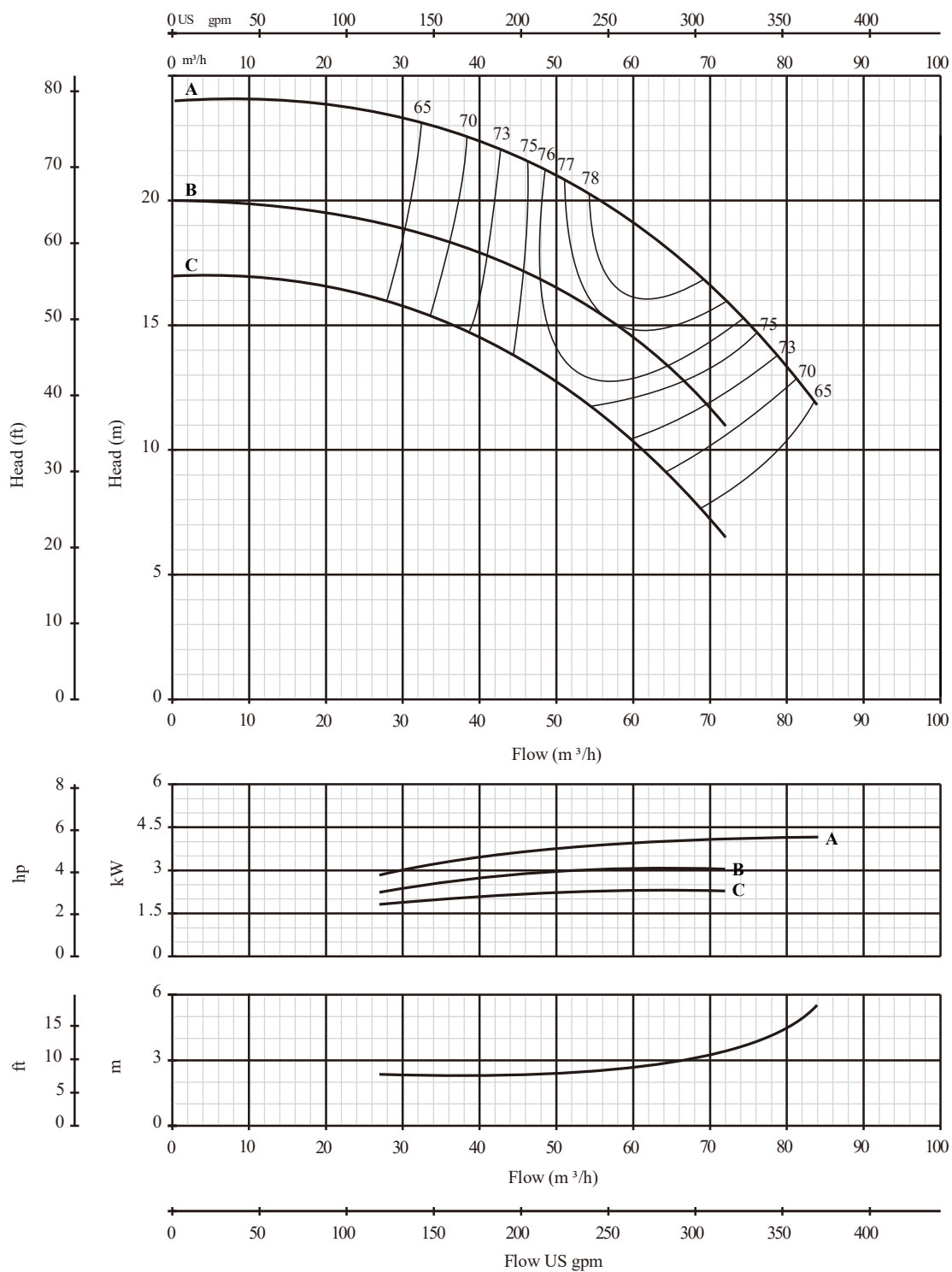

PERFORMANCE CURVE

50-160

2900rpm

PERFORMANCE CURVE

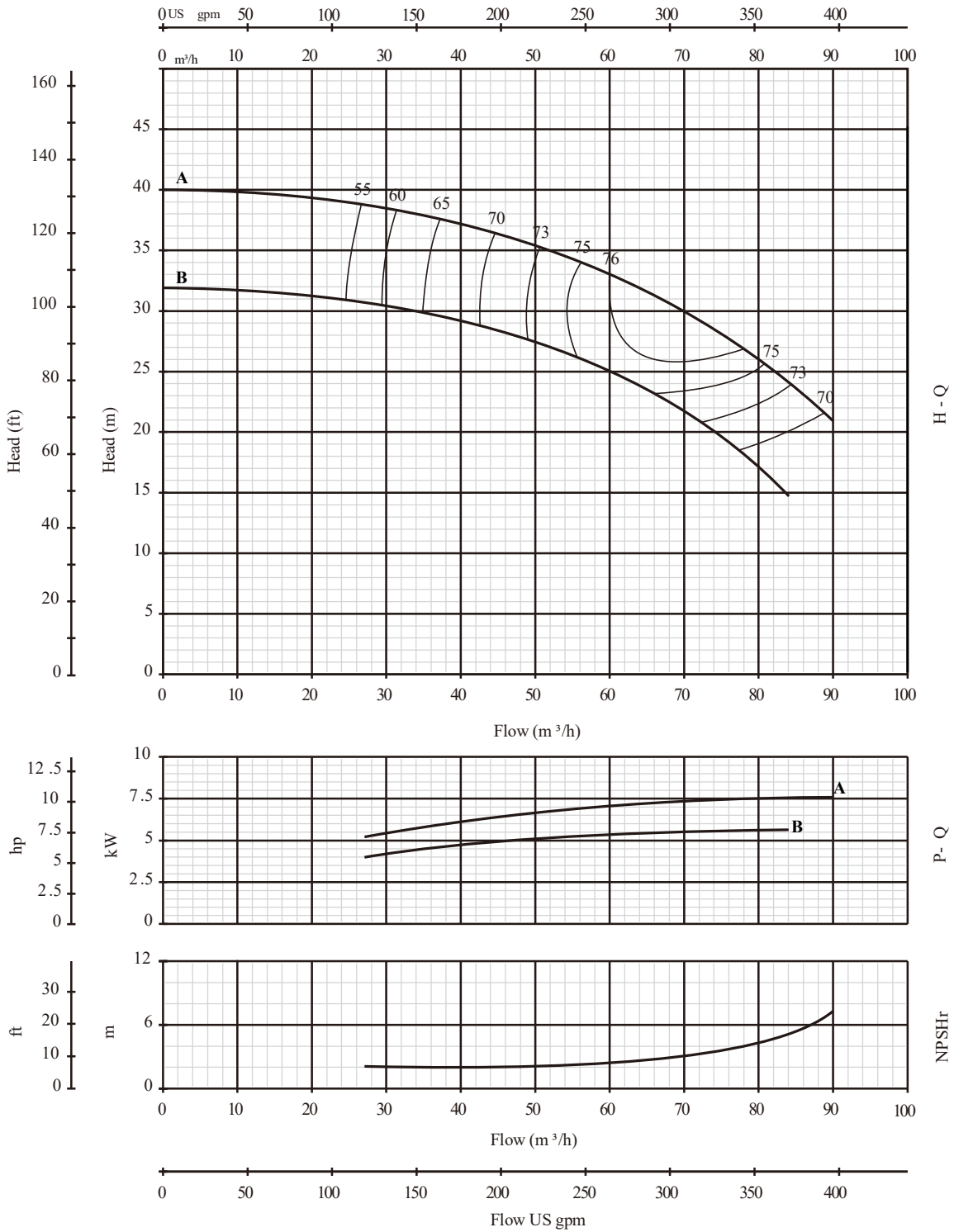

50-200

2900rpm

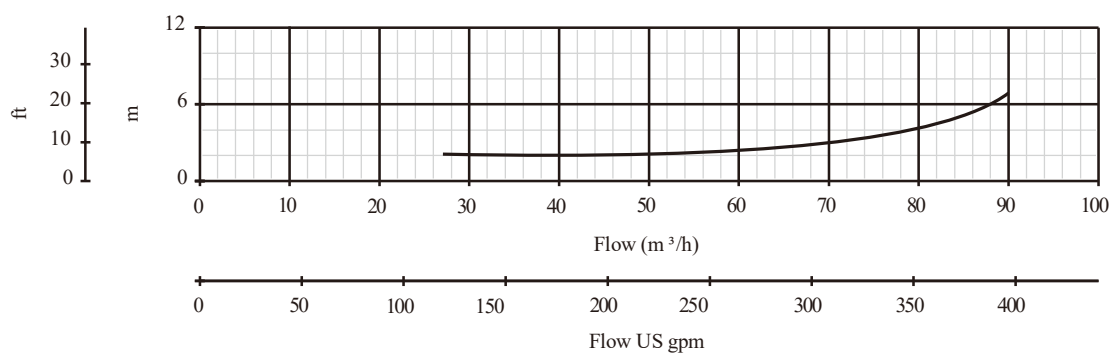
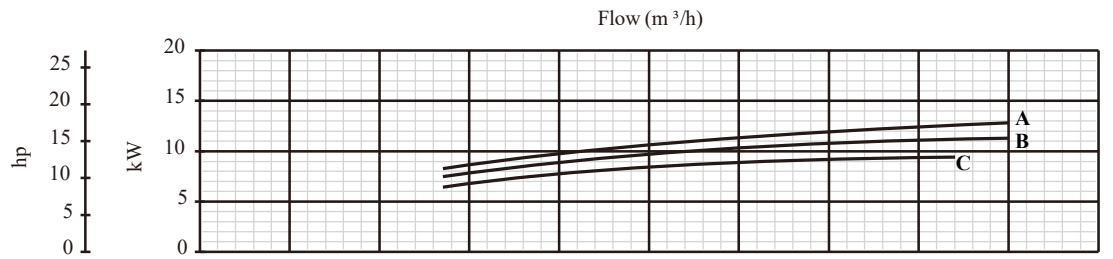
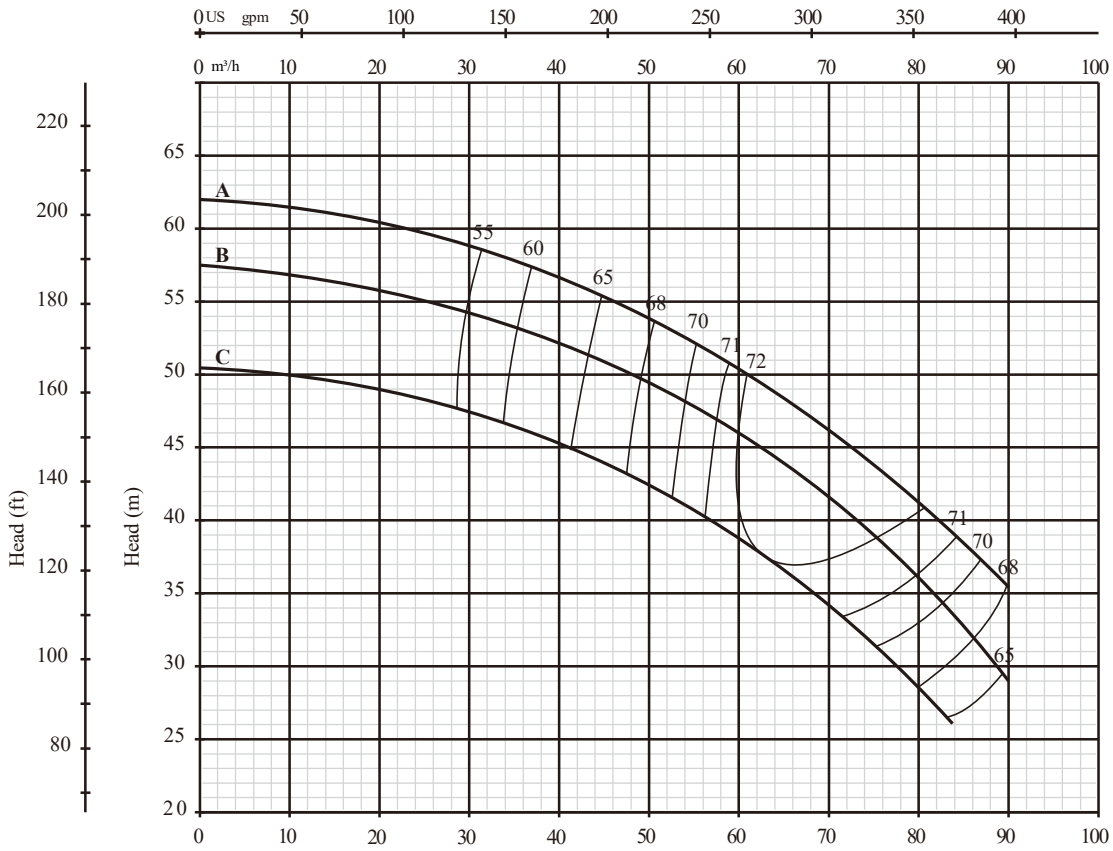

PERFORMANCE CURVE

50-250

2900rpm

PERFORMANCE CURVE

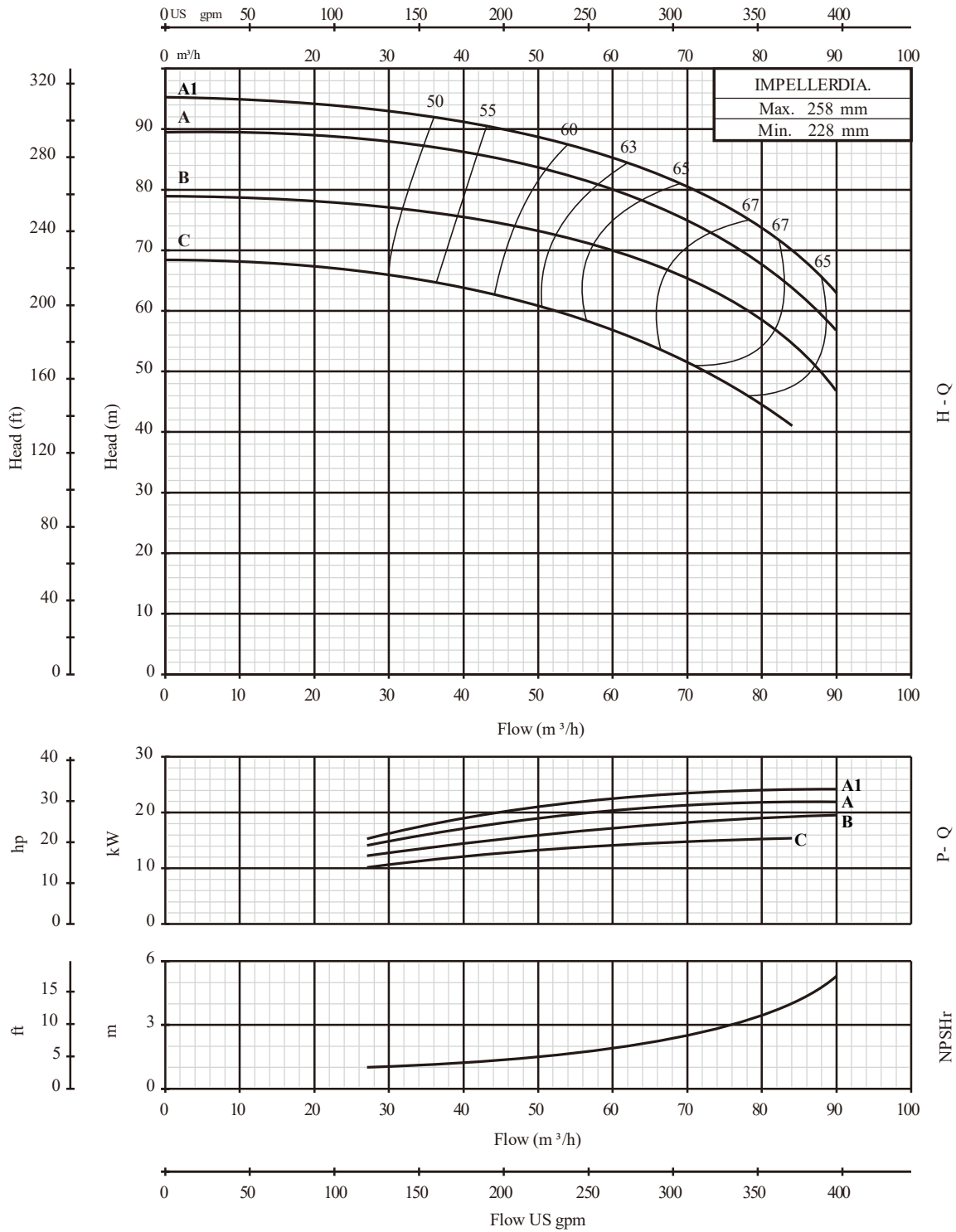

65-125

2900rpm

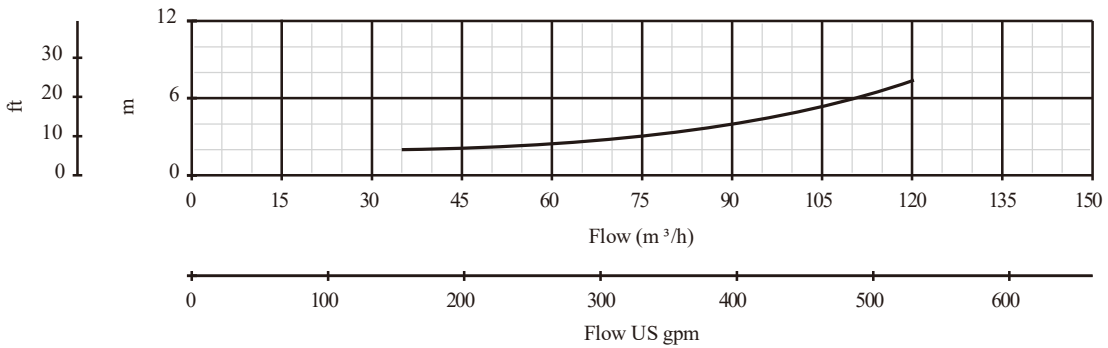
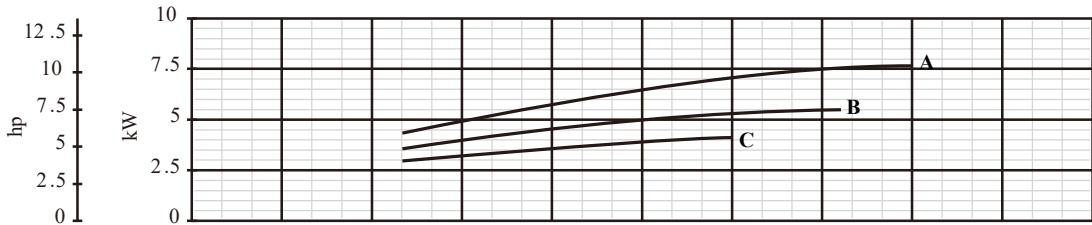
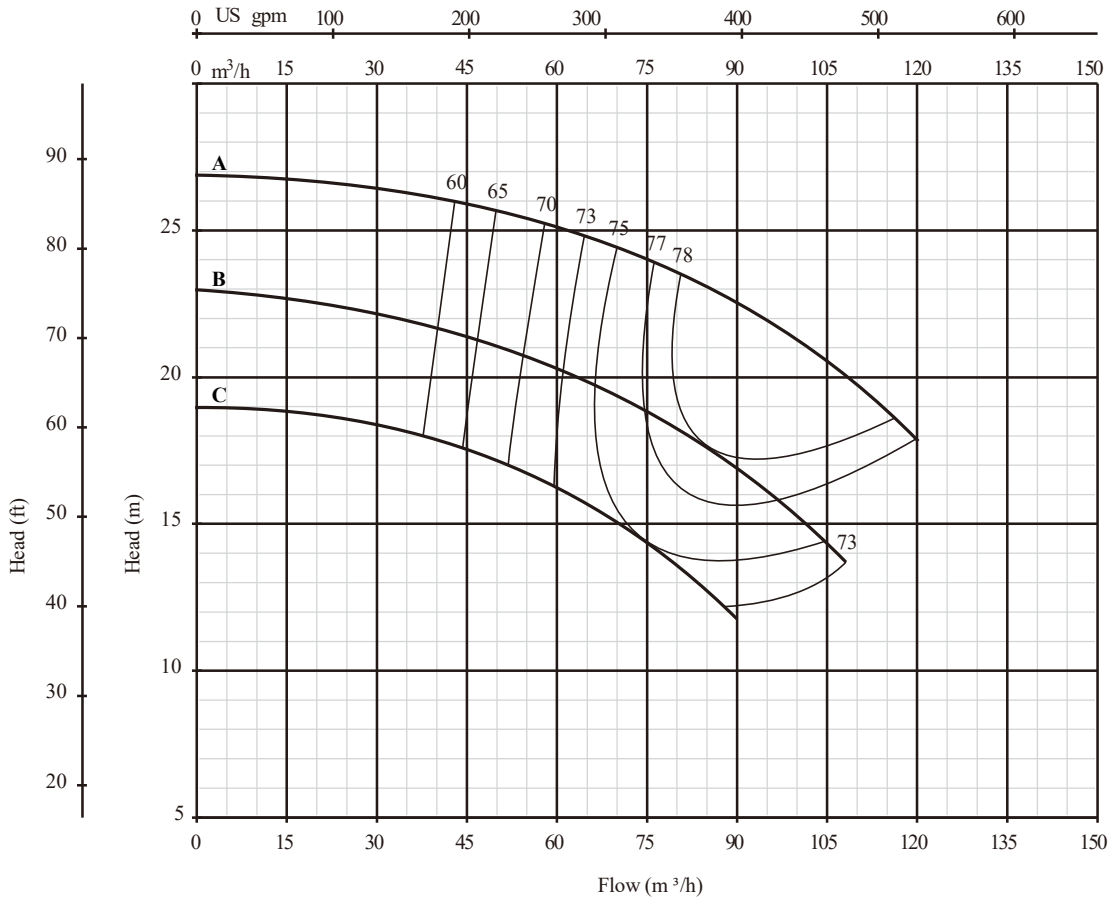

PERFORMANCE CURVE

65-160

2900rpm

PERFORMANCE CURVE

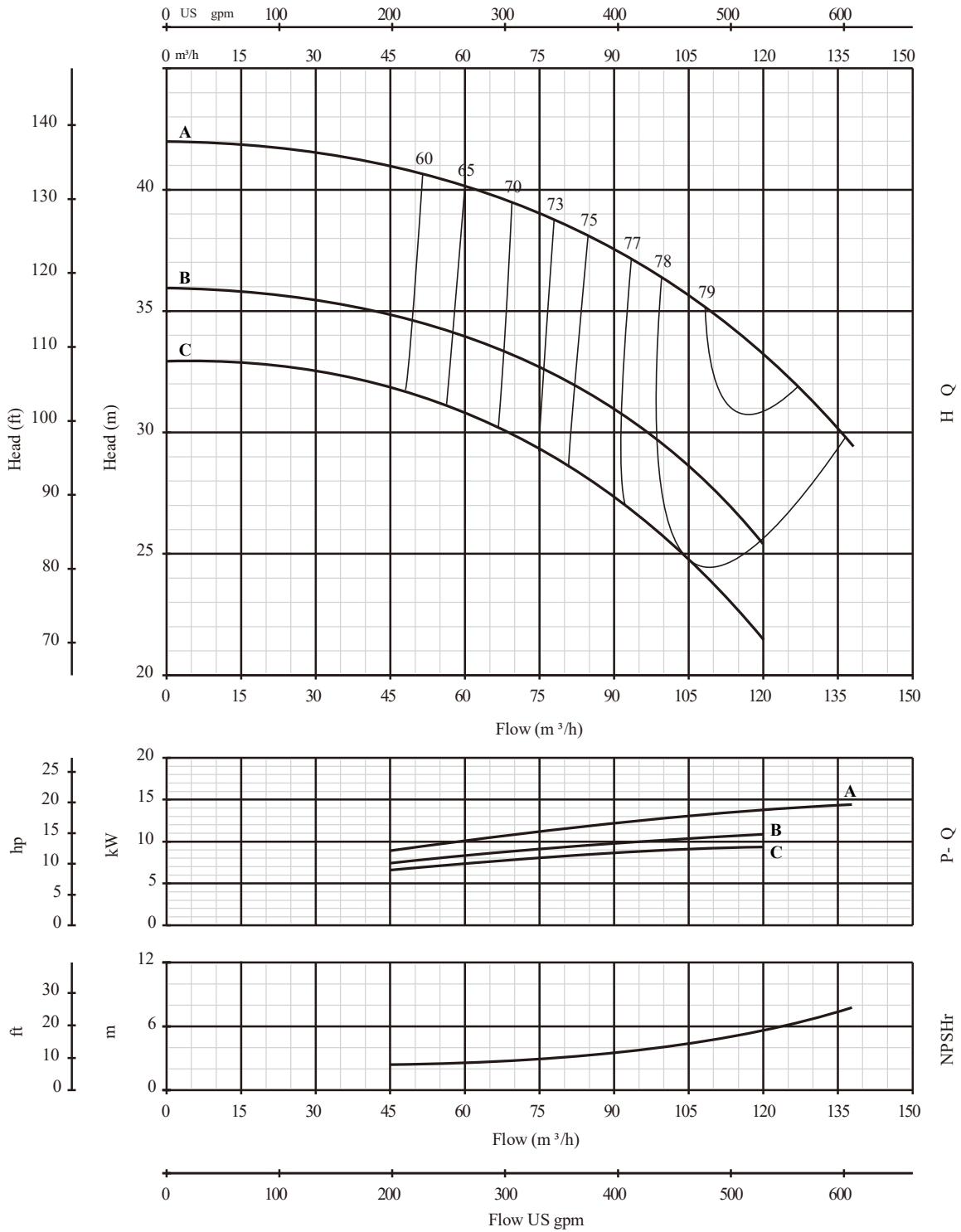

65-200

2900rpm

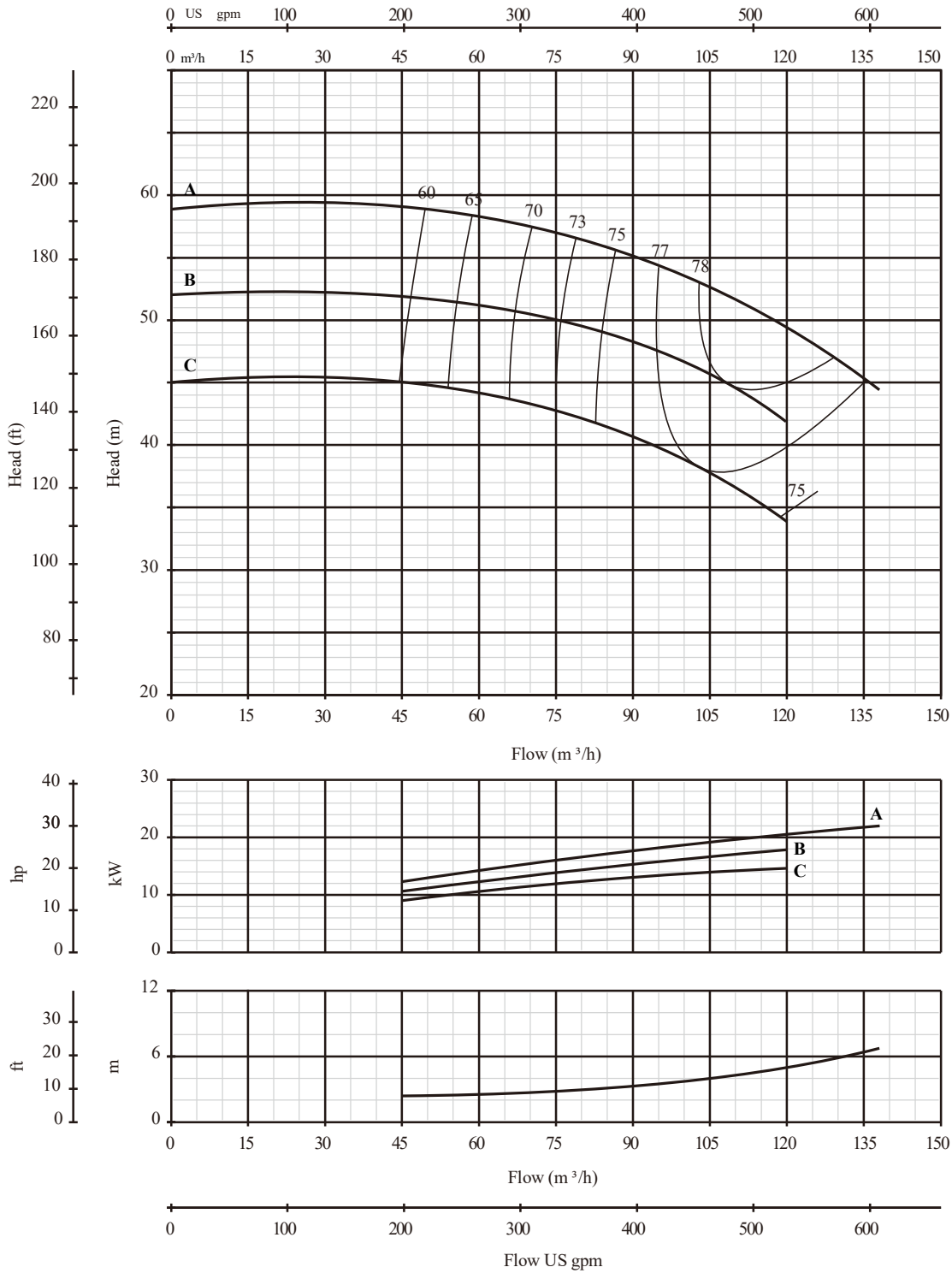

PERFORMANCE CURVE

65-250

2900rpm

PERFORMANCE CURVE

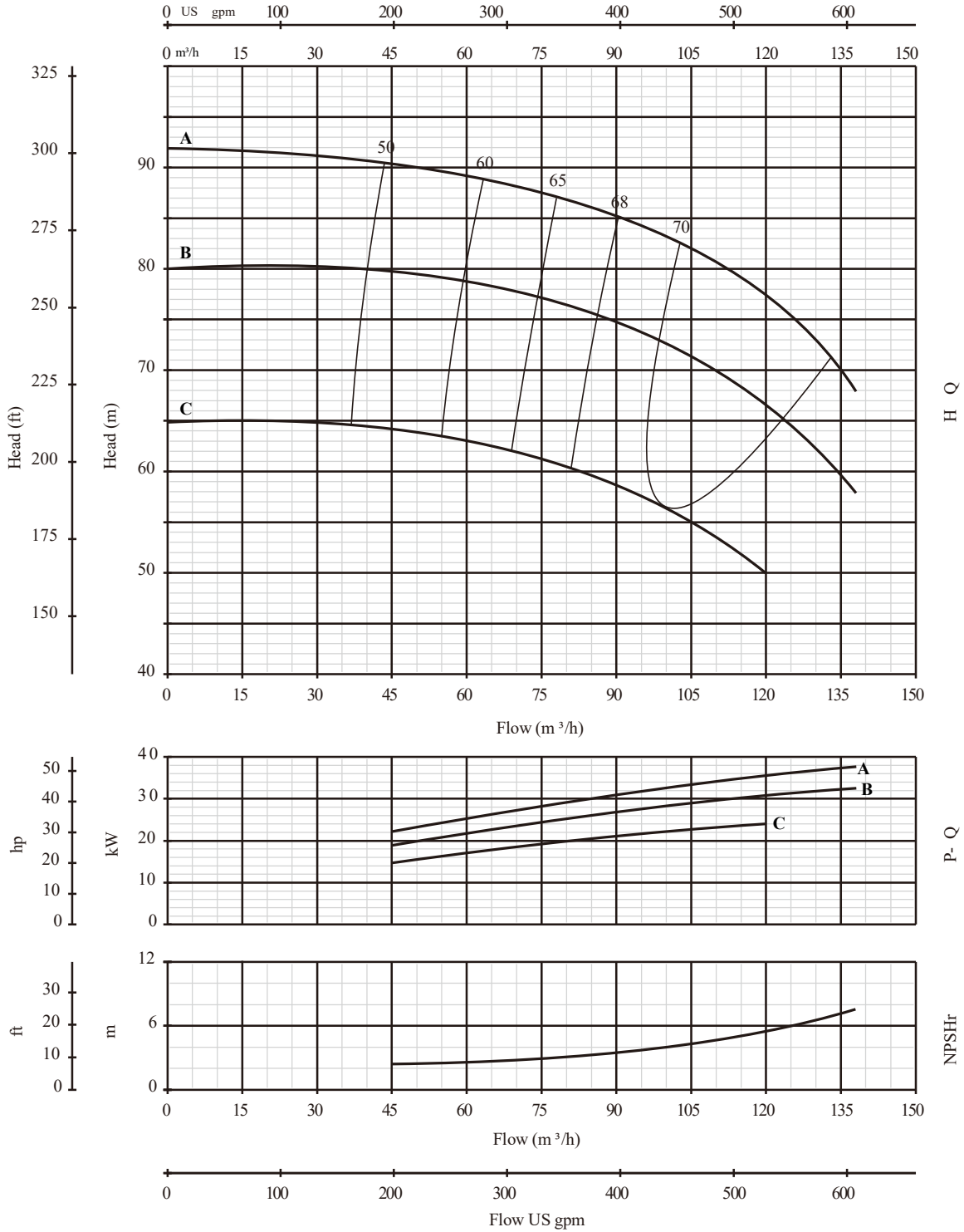

65-315

2900rpm

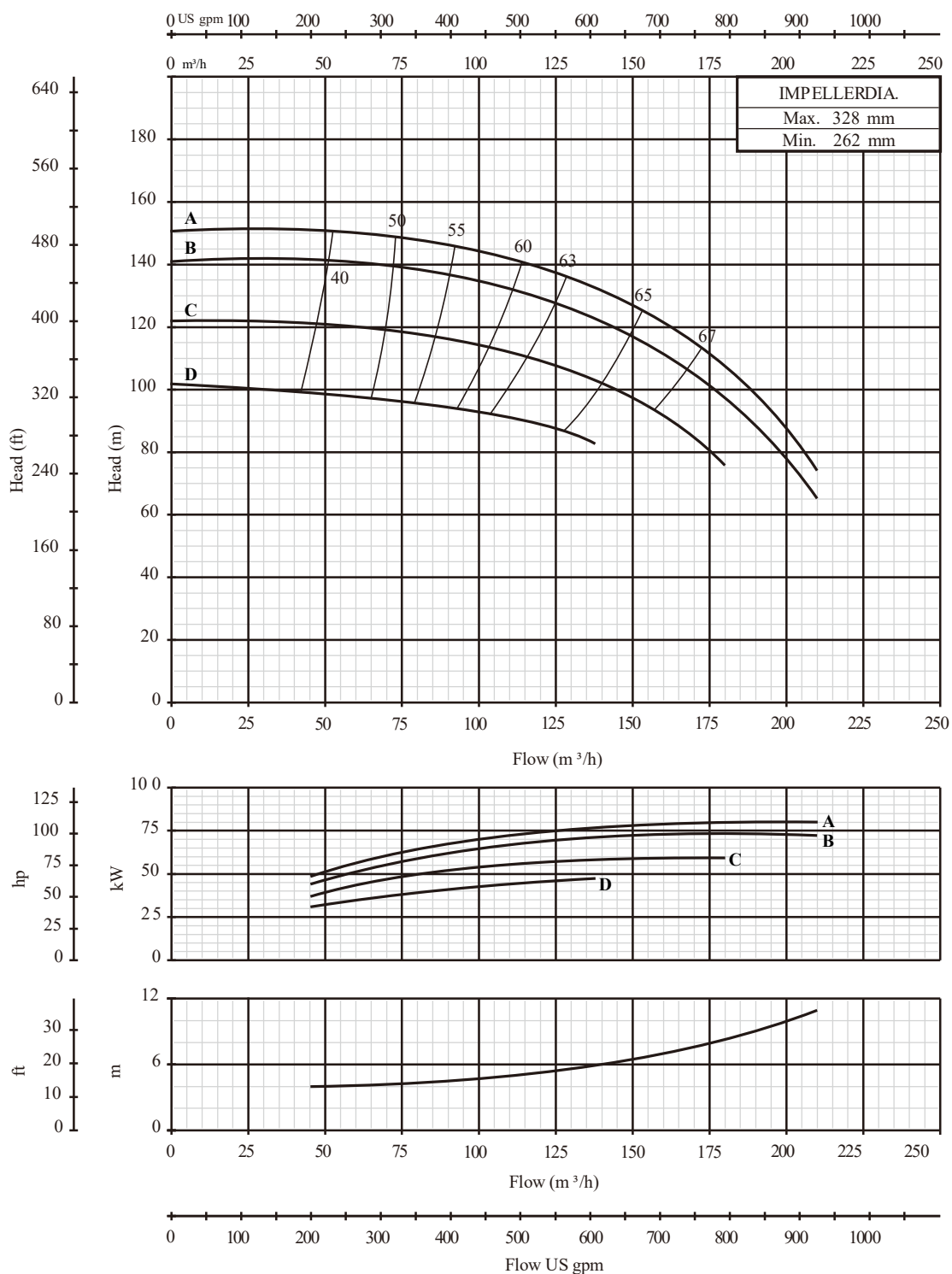

PERFORMANCE CURVE

80-125

2900rpm

PERFORMANCE CURVE

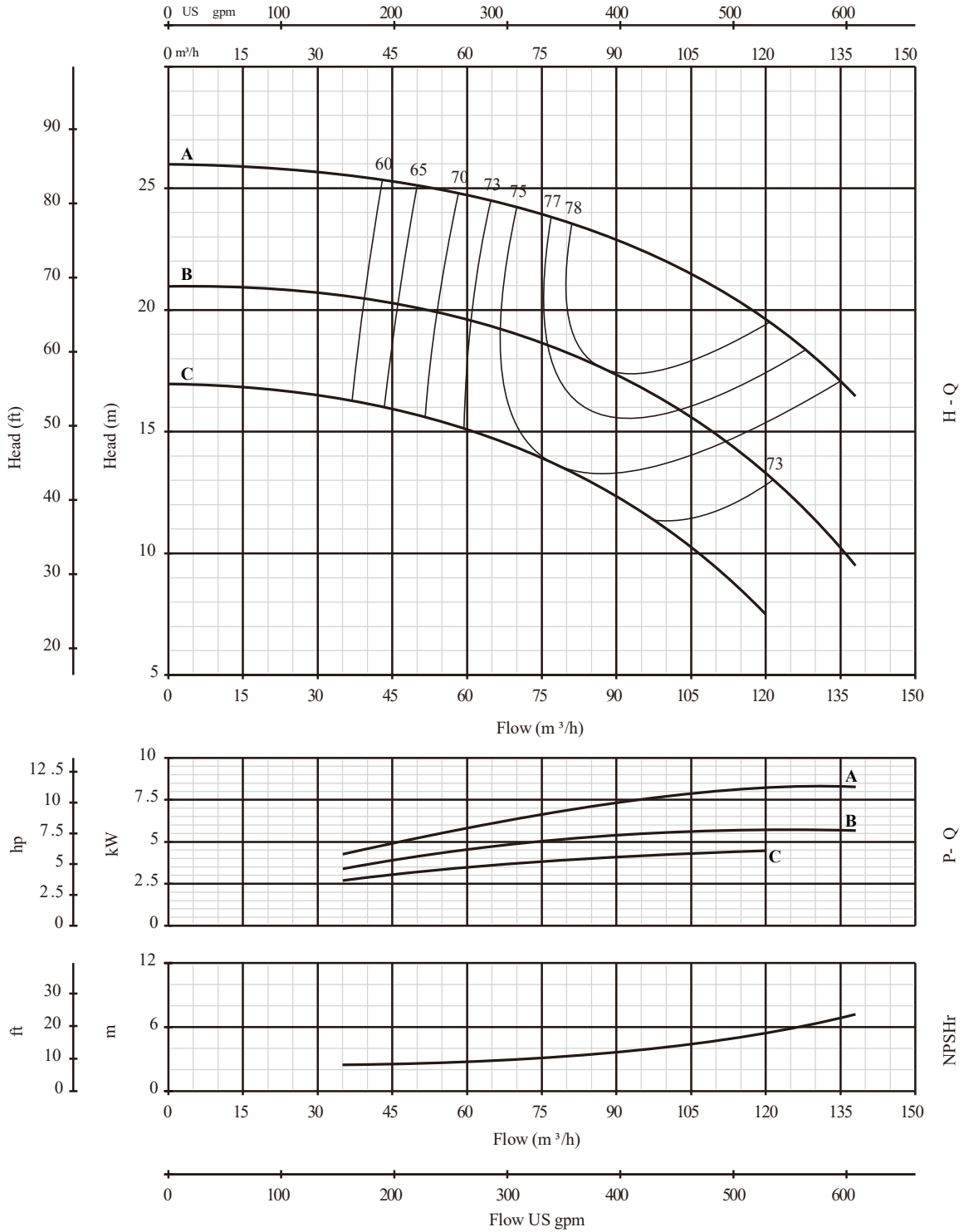

80-160

2900rpm

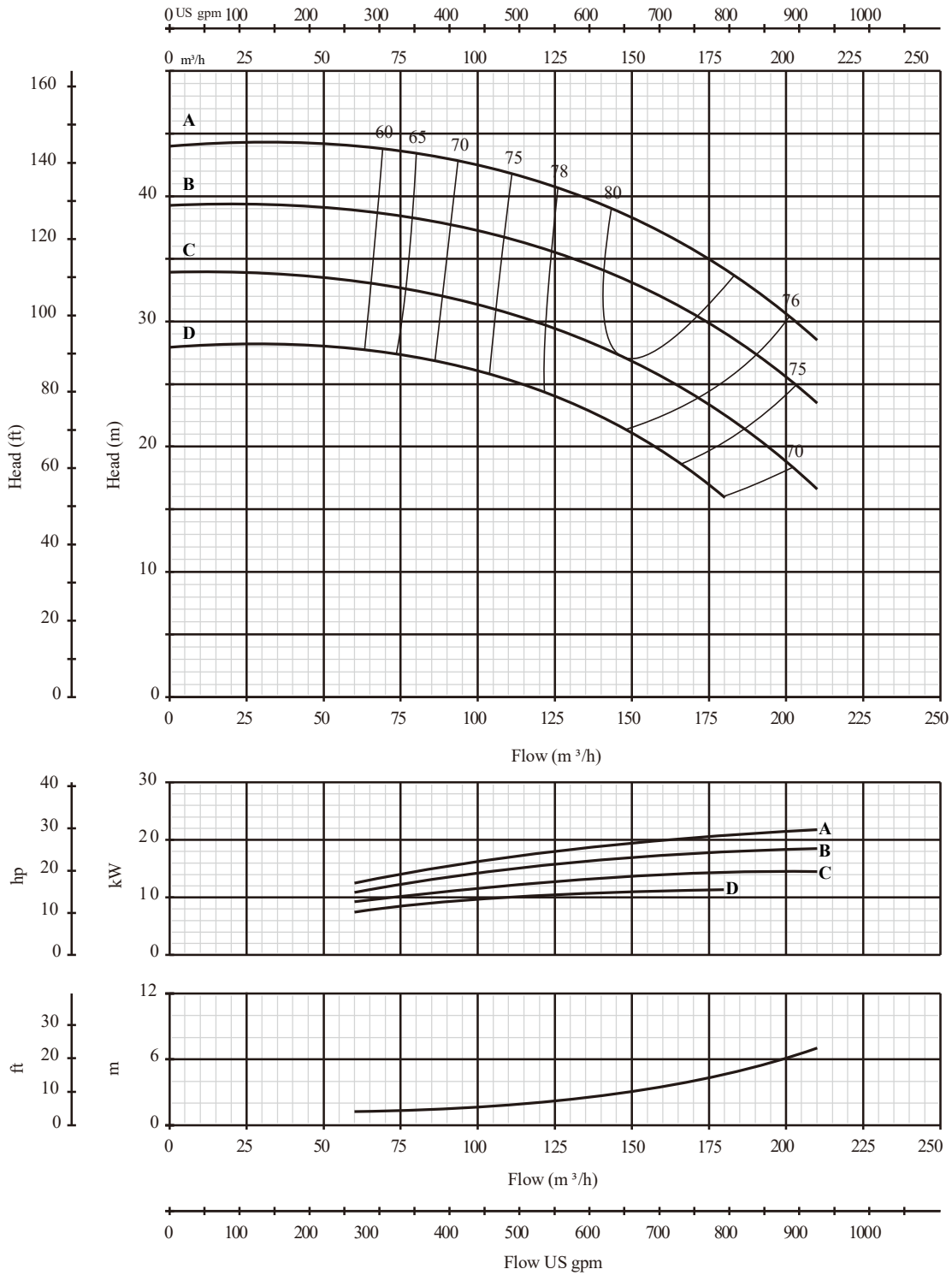

H - Q

P - Q

NPSHr

PERFORMANCE CURVE

80-200

2900rpm

PERFORMANCE CURVE

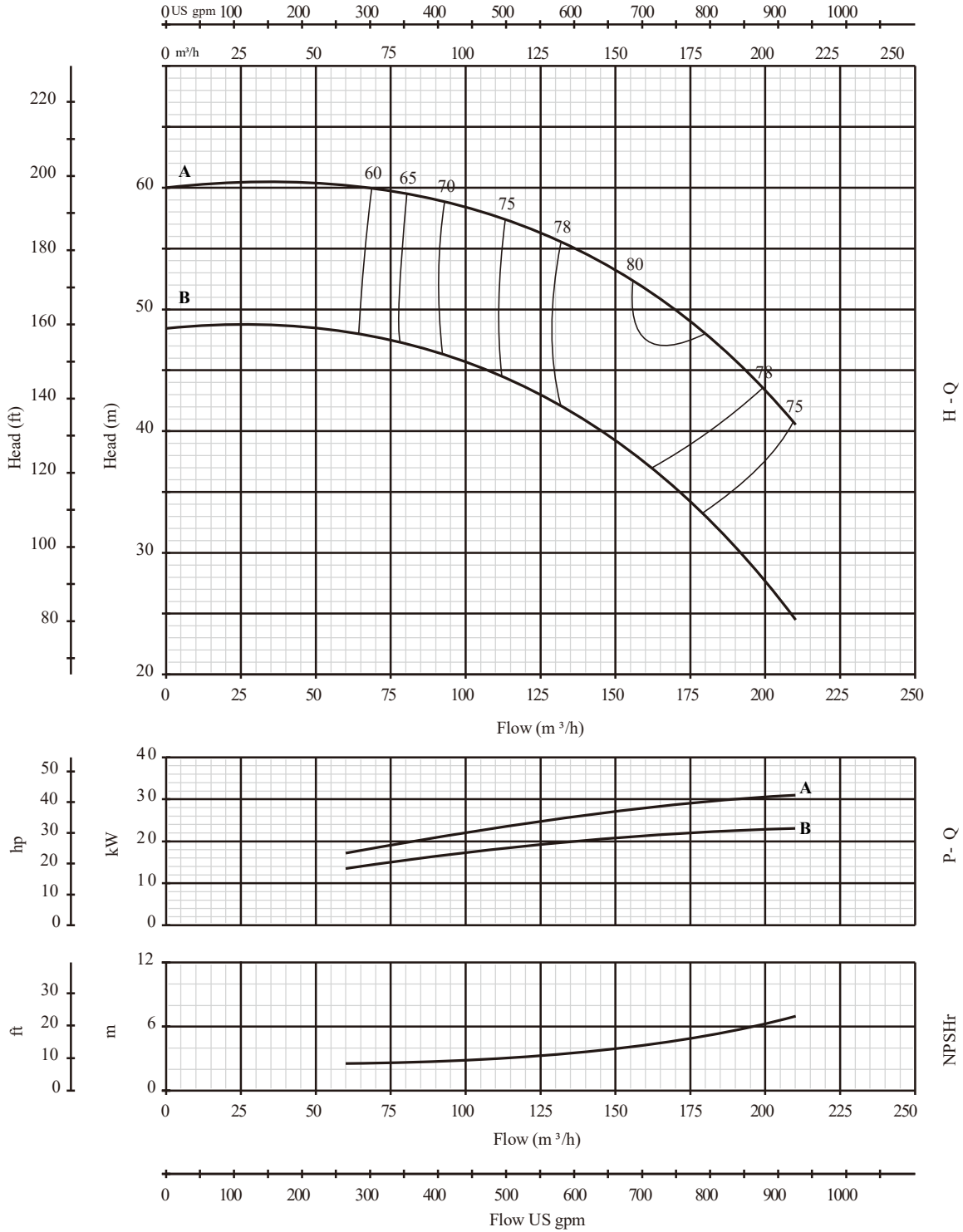

80-250

2900rpm

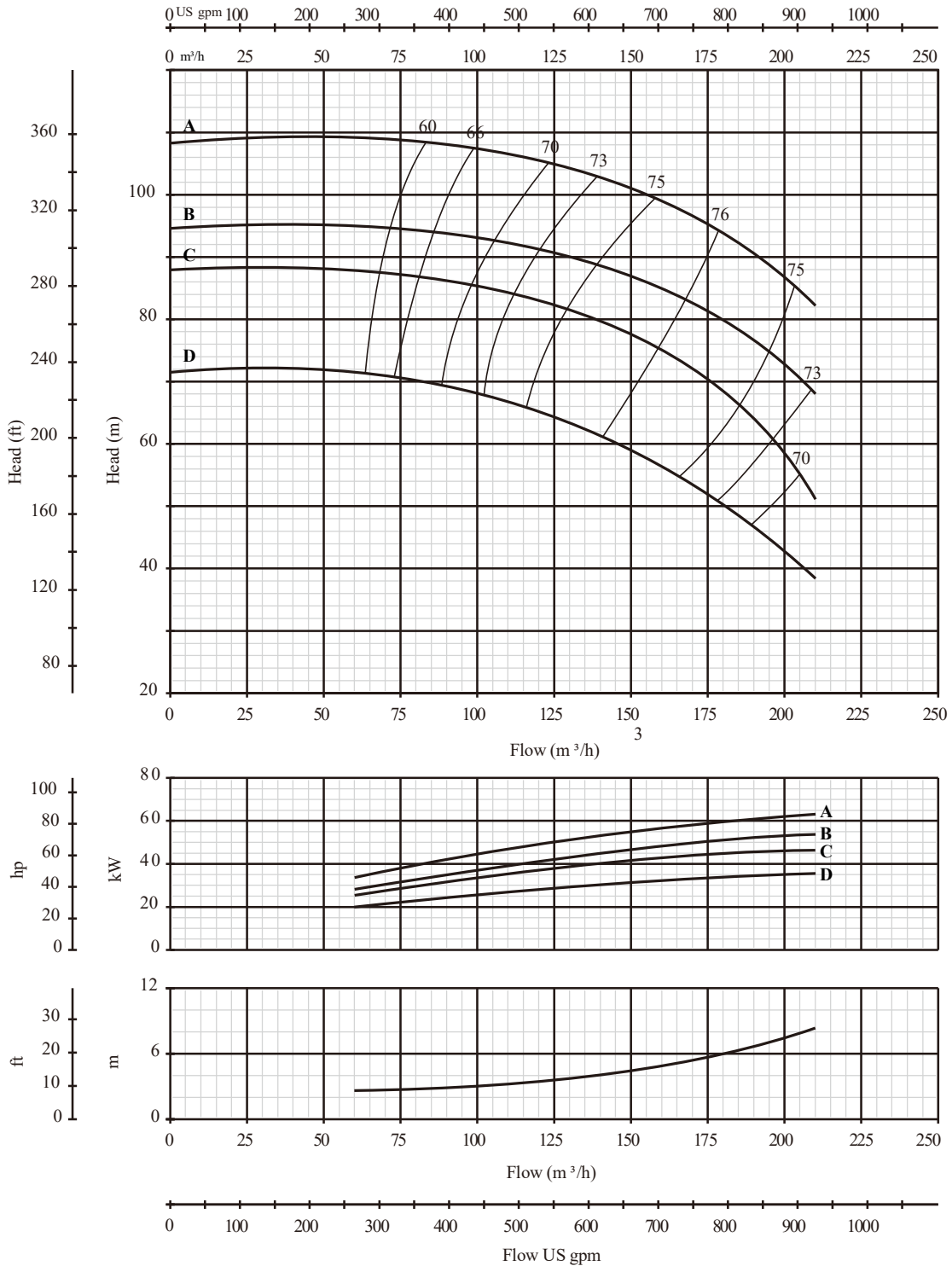

H - Q

P - Q

NPSHr

PERFORMANCE CURVE

80-315

2900rpm

PERFORMANCE CURVE

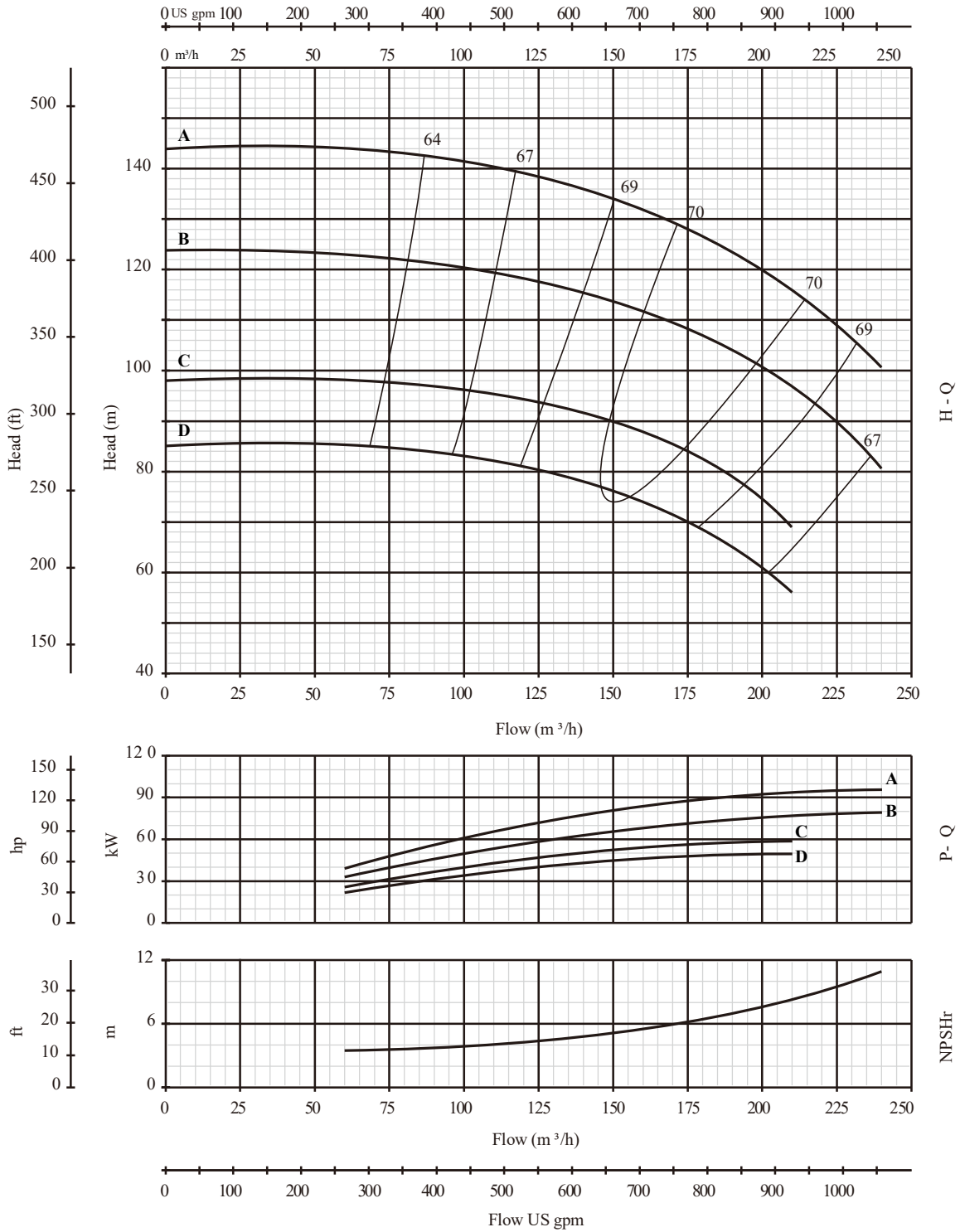

100-160

2900rpm

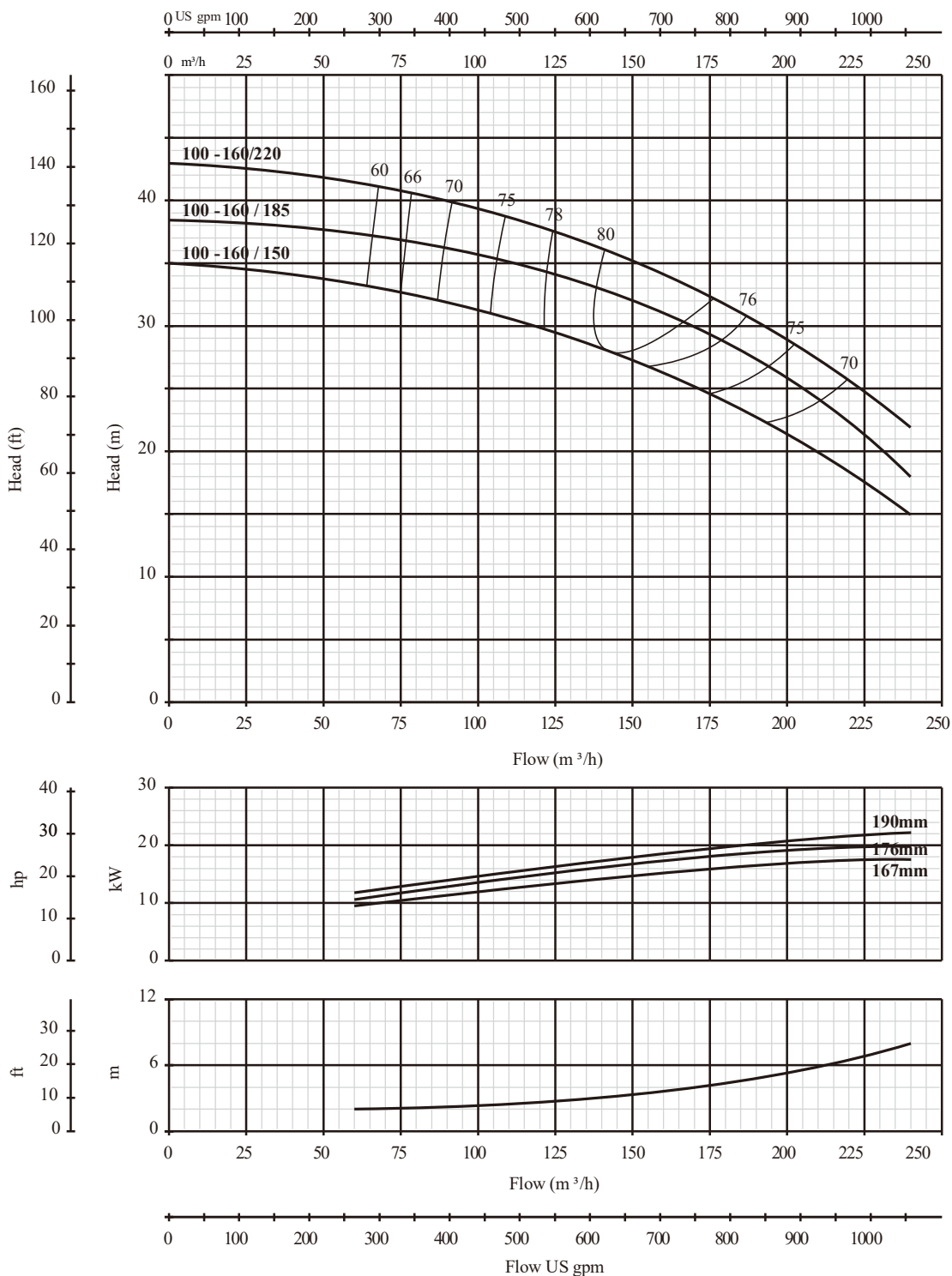

H - Q

P - Q

NPSHr

PERFORMANCE CURVE

PERFORMANCE CURVE

100-200

2900rpm

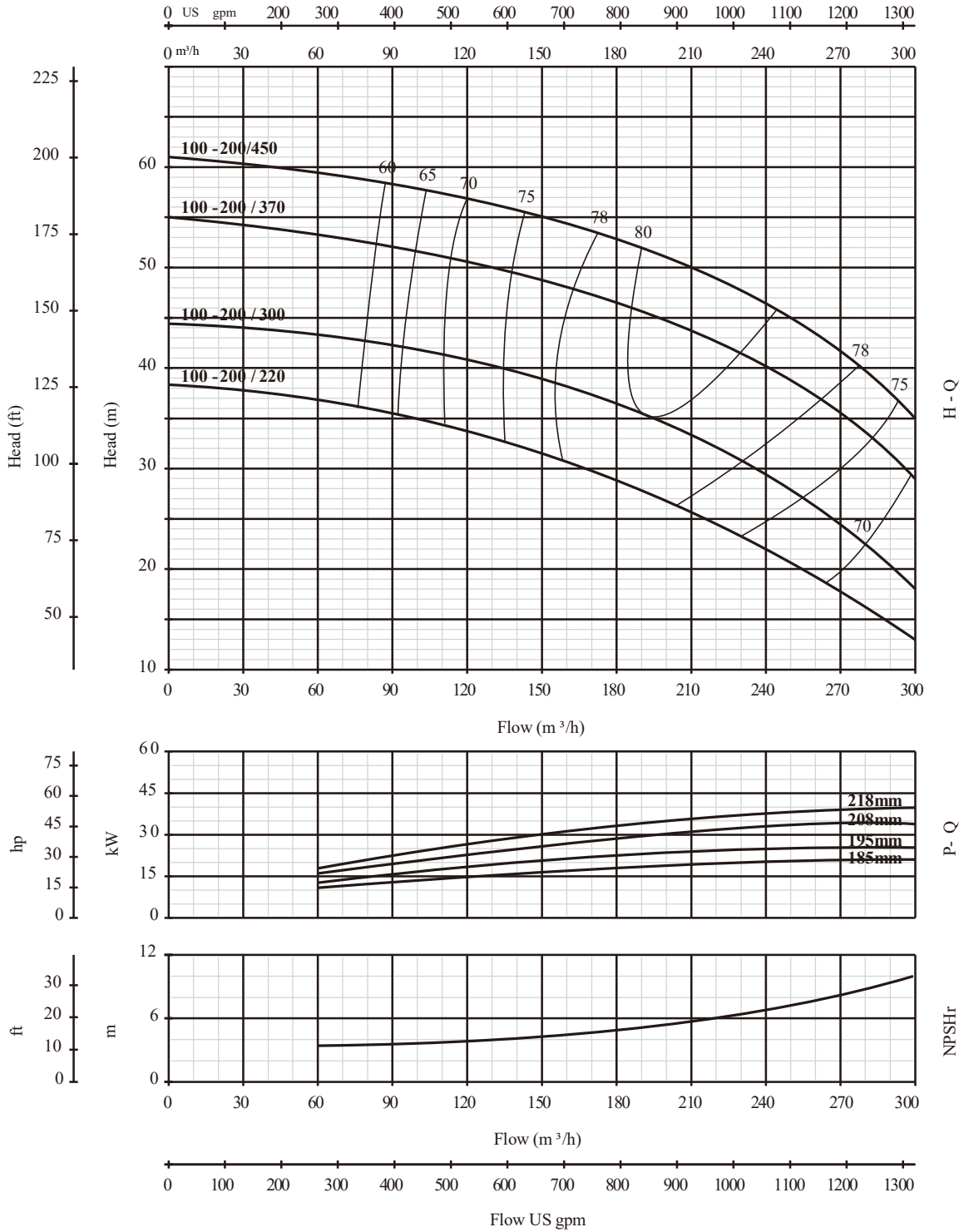

100-250

2900rpm

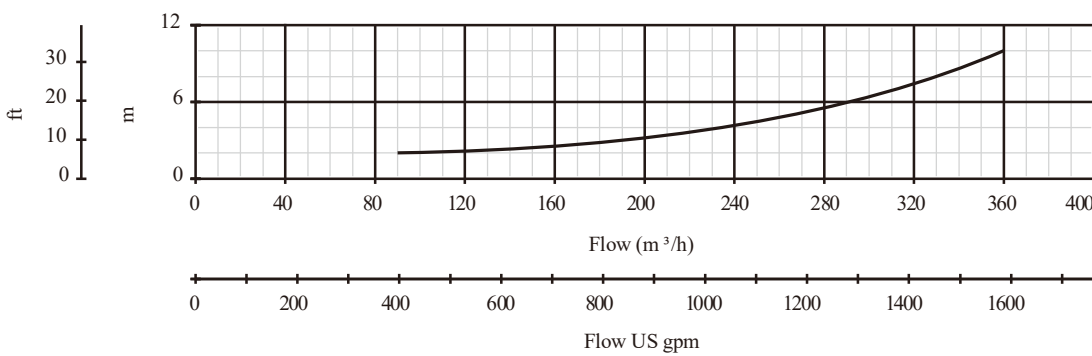
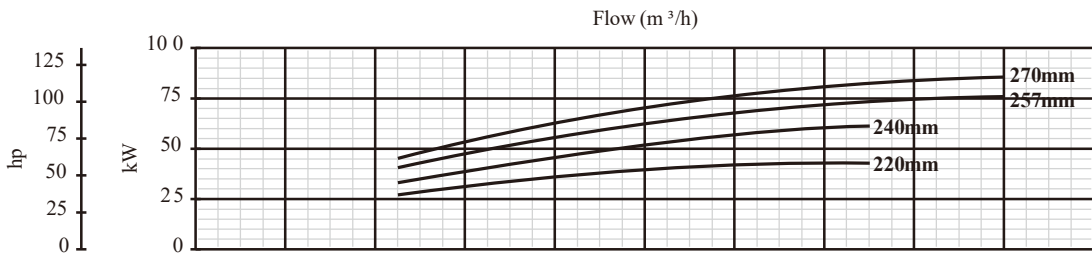
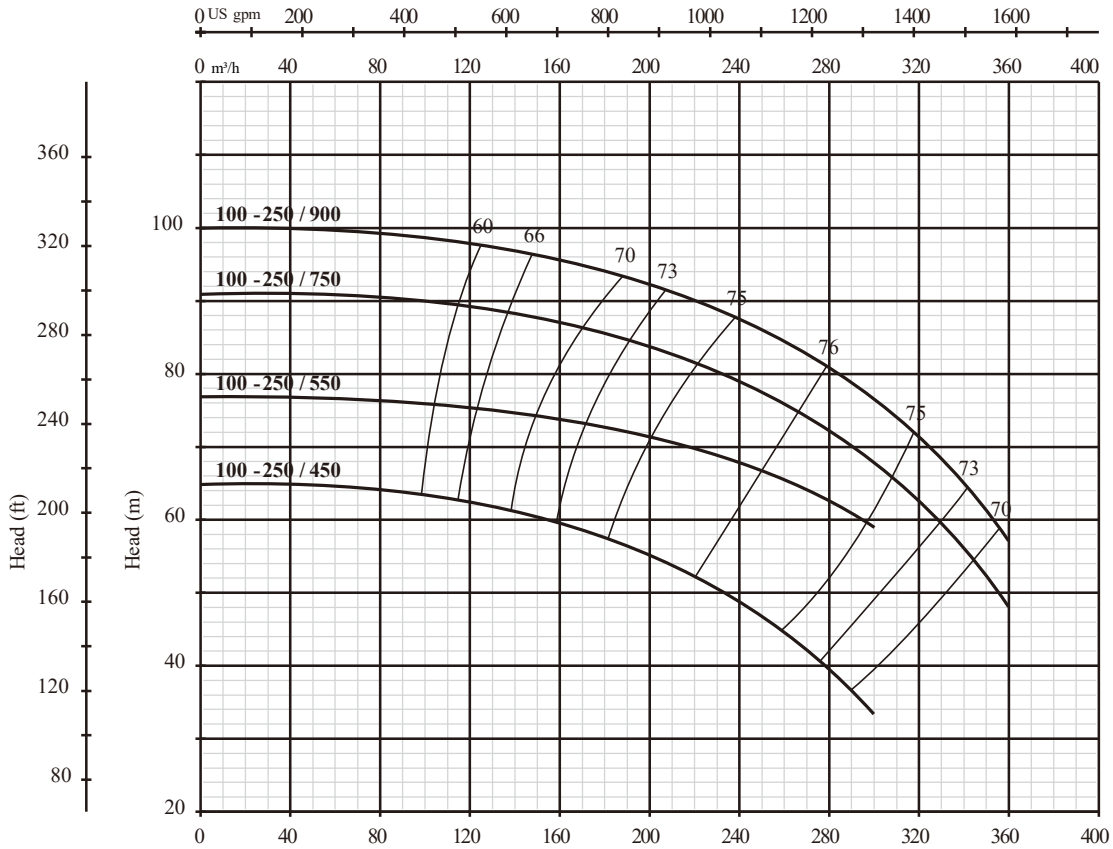

H - Q

P - Q

NPSHr

PERFORMANCE CURVE

100-315

2900rpm

PERFORMANCE CURVE

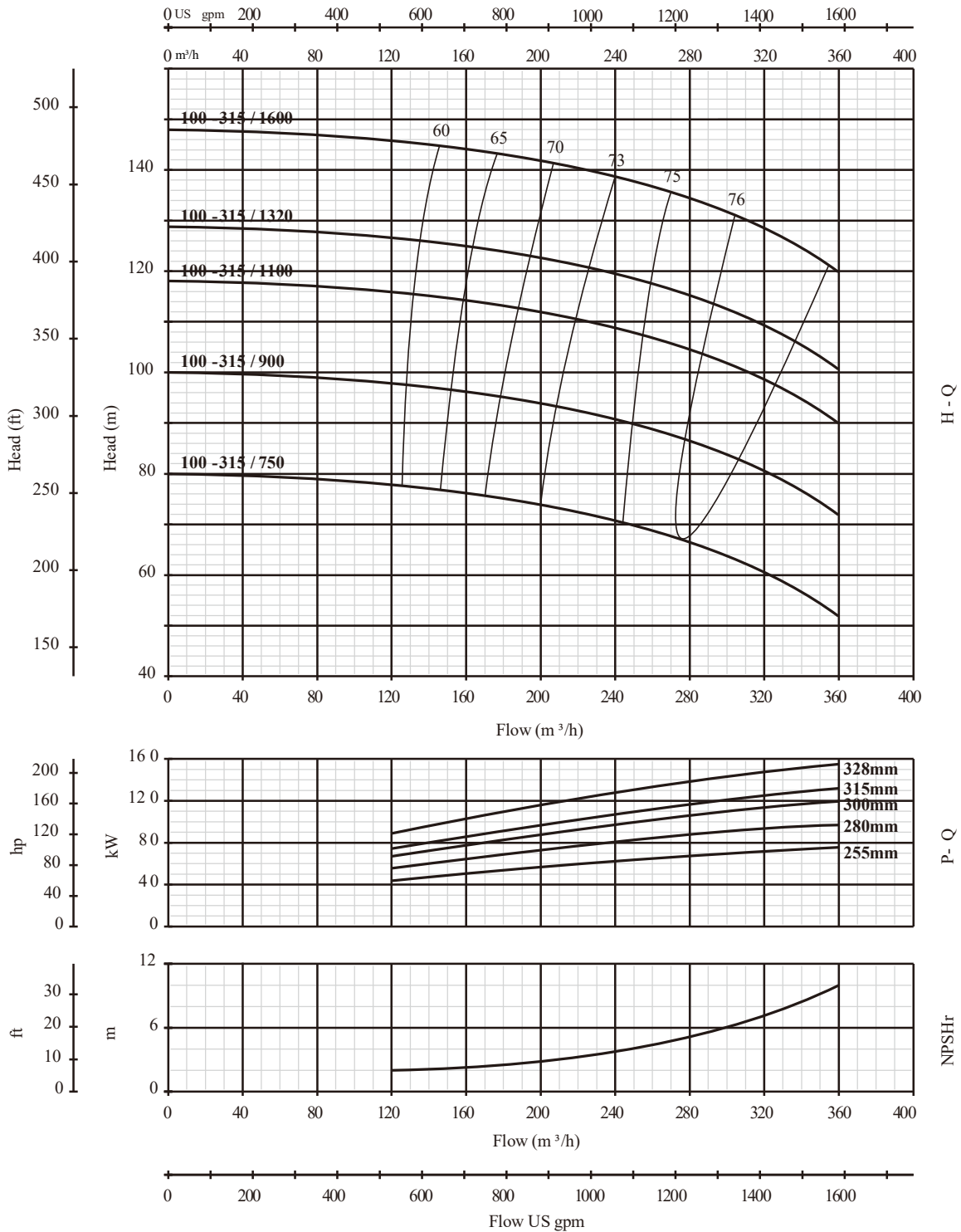

125-200

2900rpm

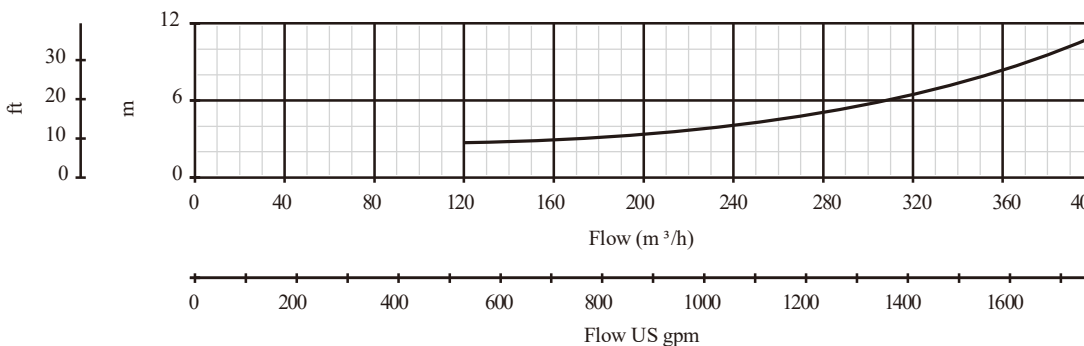
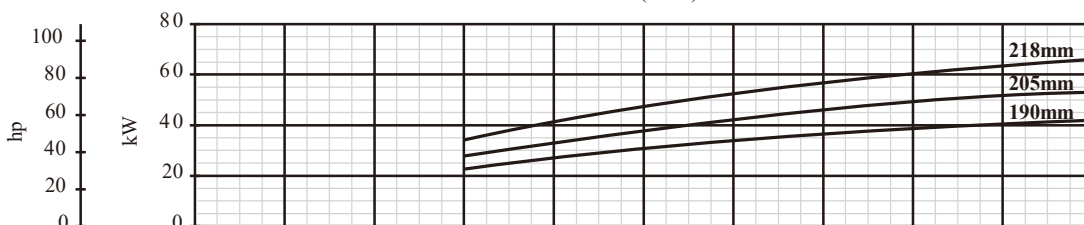
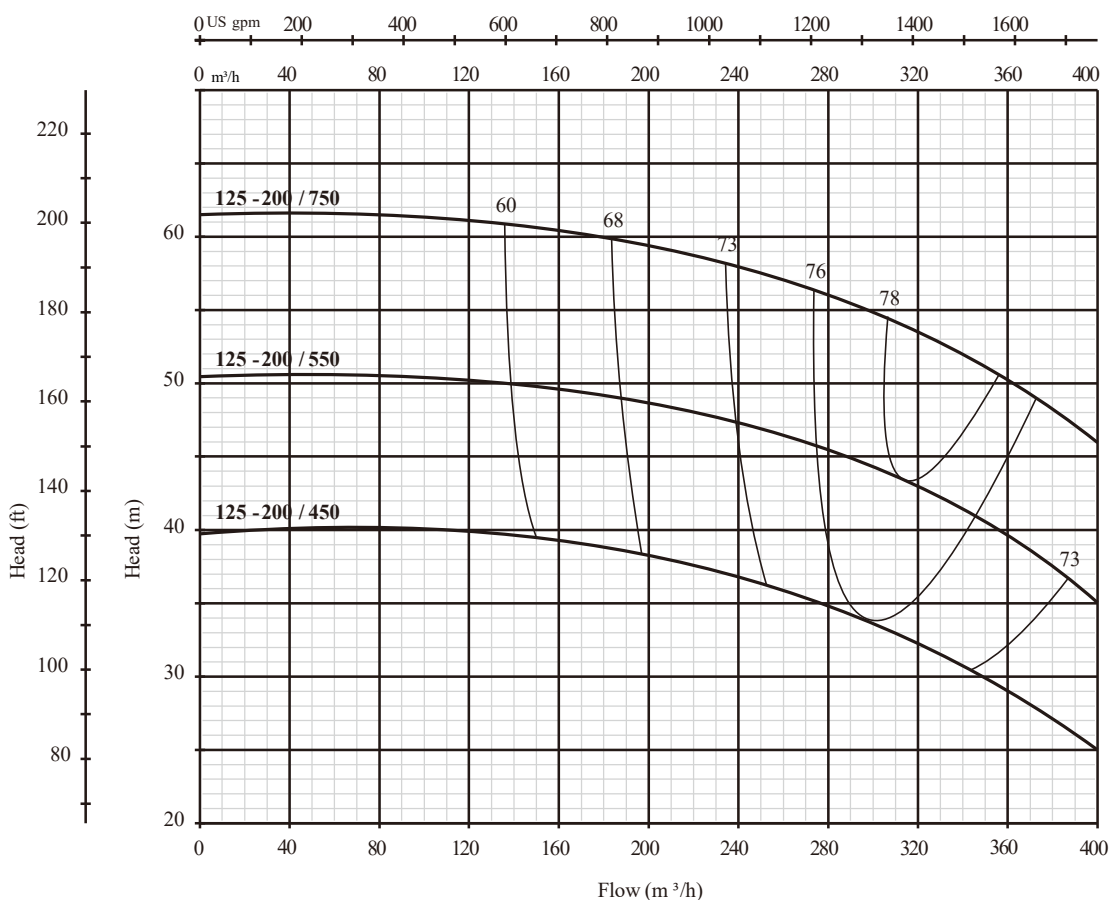

PERFORMANCE CURVE

PERFORMANCE CURVE

125-250

2900rpm

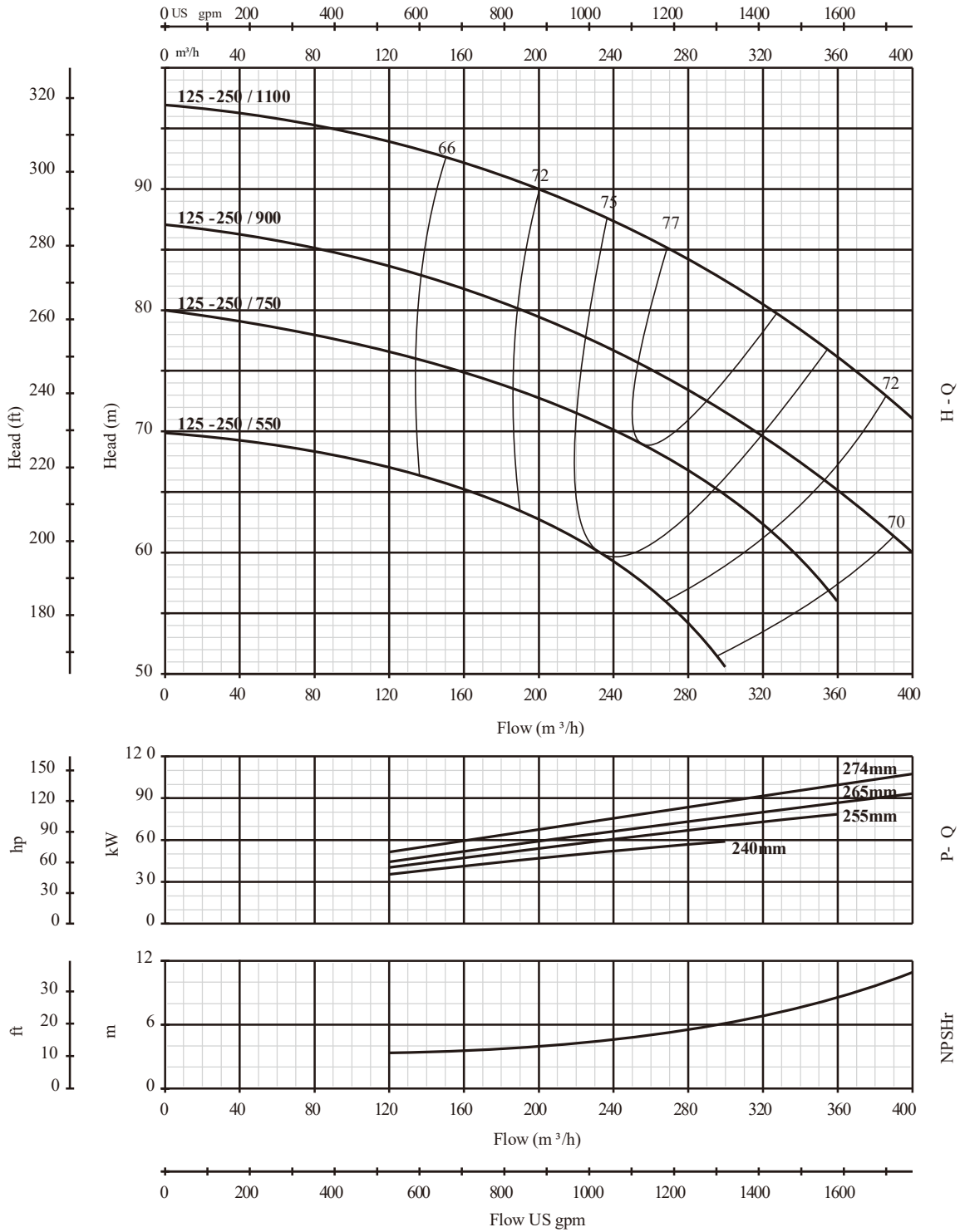

DESCRIPTION

- ◆ Complete range with a full series of end suction pumps
- ◆ Original design by MARO
- ◆ Outstanding reliability for operation in any application
- ◆ YE3 high efficient motor, with protection IP55 class F
- ◆ Pump case with anti-corrosive coating
- ◆ Customize casting logo on the bearing house as request
- ◆ Quality NSK bearing, wear resistance mechanical seal

APPLICATIONS

The impressive range end-suction pumps is compatible with an array of application areas, including water intake, heating, industrial pressure boosting, industrial liquid transfer, air-conditioning, district cooling, irrigation, fire fighting and many more.



CA/CA4

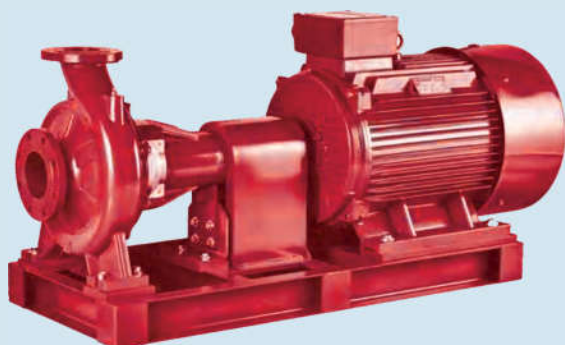

MODEL CODE

For example

CA/CA4 32 - 250

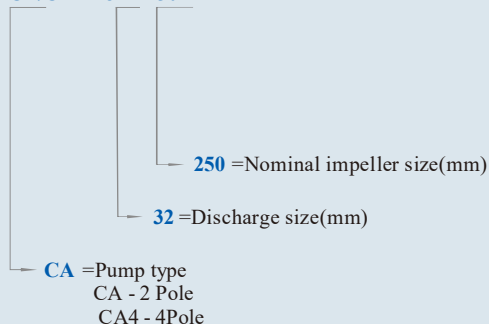

USING LIMITS

- ◆ Liquid temperature between -10°C and $+120^{\circ}\text{C}$
- ◆ Ambient temperature between -10°C and $+50^{\circ}\text{C}$
- ◆ Max. working pressure **16 bar**
- ◆ Continuous service **S1**

TECHNICAL SHEET

Model	CA/CA4	
Capacity	0-1000	m ³ /h
Head	0-164	m
DN	32-150	mm
Speed	2900	rpm
T max	120	°C
Power	1.5-315	kW
Casing	Grey cast iron	
Impeller	Cast iron/AISI 304/Brass	
Shaft	45# steel/AISI 304	
Shaft seal	Mechanical Seal	
Bearing	Grease lubrication rolling bearing	

CA/CA4

End suction centrifugal pump

TECHNICAL DATA

50 Hz n=2900 1/min

MODEL	DN mm	Implr Φ mm	Power kw hp		Q-DELIVERY																				
					us		0	26	40	66	79	106	119	159	185	211	238	317	370	396	476	529	608	793	925
					gpm		0	100	150	250	300	400	450	600	700	800	900	1200	1400	1500	1800	2000	2300	3000	3500
					l/min		0	6	9	15	18	24	27	36	42	48	54	72	84	90	108	120	138	180	210
H=Head																									
CA 32-160	50x32	142	1.5	2	25.4	23.7	22.5	18.5	15.8	-	-	-	-	-	-	-	-	-	-	-	-	-			
CA 32-160	50x32	158	2.2	3	31	29.6	28.5	24.5	22	15	-	-	-	-	-	-	-	-	-	-	-	-			
CA 32-160	50x32	168	3	4	35	34.3	32.5	28	25.5	19	15	-	-	-	-	-	-	-	-	-	-	-			
CA 32-200	50x32	190	3	4	44.2	42	39.8	35.2	32.2	24.6	19.8	-	-	-	-	-	-	-	-	-	-	-			
CA 32-200	50x32	204	4	5.5	54.5	52	50	45.5	42.3	35	30.3	-	-	-	-	-	-	-	-	-	-	-			
CA 32-250	50x32	208	5.5	7.5	60	59.5	59	55	50.2	34.5	-	-	-	-	-	-	-	-	-	-	-	-			
CA 32-250	50x32	230	7.5	10	69.5	69	68.5	66	63	53	-	-	-	-	-	-	-	-	-	-	-	-			
CA 32-250	50x32	237	9.2	12.5	75	75	74.5	72	69	59	-	-	-	-	-	-	-	-	-	-	-	-			
CA 32-250	50x32	250	11	15	90	89.5	88	82	78	66	-	-	-	-	-	-	-	-	-	-	-	-			
CA 32-250	50x32	258	15	20	97	96.5	96	90	86	73	-	-	-	-	-	-	-	-	-	-	-	-			
CA 40-160	65x40	160	3	4	31.8	-	-	-	29.5	27.5	26.3	21.5	17.5	-	-	-	-	-	-	-	-	-			
CA 40-160	65x40	170	4	5.5	38	-	-	-	36	34	33	28.5	25	20.1	-	-	-	-	-	-	-	-			
CA 40-200	65x40	195	5.5	7.5	46	-	-	-	43.8	41.3	40.1	35	30	-	-	-	-	-	-	-	-	-			
CA 40-200	65x40	209	7.5	10	57	-	-	-	53.6	51.5	50	45	41	36.5	-	-	-	-	-	-	-	-			
CA 40-250	65x40	224	9.2	12.5	64	-	-	-	59	56.5	55	49.5	45	39.8	-	-	-	-	-	-	-	-			
CA 40-250	65x40	230	11	15	72	-	-	-	67.5	65	63.5	57.5	52.2	47	-	-	-	-	-	-	-	-			
CA 40-250	65x40	250	15	20	84.5	-	-	-	79.3	77.3	75.2	70	66	61	-	-	-	-	-	-	-	-			
CA 40-250	65x40	258	18.5	25	90	-	-	-	85.5	82.8	80.7	75.8	70.5	66.5	-	-	-	-	-	-	-	-			
CA 40-315	65x40	260	18.5	25	95	-	-	-	95	93	92.5	87	81	-	-	-	-	-	-	-	-	-			
CA 40-315	65x40	275	22	30	106	-	-	-	106	104	103.5	98	92	-	-	-	-	-	-	-	-	-			
CA 40-315	65x40	290	30	40	120	-	-	-	120	118	117	115	112	-	-	-	-	-	-	-	-	-			
CA 40-315	65x40	322	37	50	144	-	-	-	144	143	142	141	140	132	-	-	-	-	-	-	-	-			
CA 40-315	65x40	340	45	60	160	-	-	-	160	160	159	158	157	152	-	-	-	-	-	-	-	-			
CA 50-125	65x50	123	2.2	3	17	-	-	-	-	-	-	15.4	14	12.8	11.5	6.5	-	-	-	-	-	-			
CA 50-125	65x50	130	3	4	20	-	-	-	-	-	-	18.8	18	17	15.6	11	-	-	-	-	-	-			
CA 50-125	65x50	139	4	5.5	24	-	-	-	-	-	-	23.1	23	21.5	20.3	15.8	11.8	-	-	-	-	-			
CA 50-160	65x50	158	5.5	7.5	32	-	-	-	-	-	-	30.6	30	28	26.6	20.5	14.8	-	-	-	-	-			
CA 50-160	65x50	170	7.5	10	40	-	-	-	-	-	-	38	37	36	34.4	29	24	21	-	-	-	-			
CA 50-200	65x50	195	9.2	12.5	50.5	-	-	-	-	-	-	46.8	45	43	40.9	32.5	26.7	-	-	-	-	-			
CA 50-200	65x50	204	11	15	57.5	-	-	-	-	-	-	53.5	52	50	47.5	40	34	29	-	-	-	-			
CA 50-200	65x50	209	15	20	62	-	-	-	-	-	-	58	56.5	54.5	52	44.5	39	35.5	-	-	-	-			
CA 50-250	65x50	228	15	20	68.5	-	-	-	-	-	-	64	63	61.5	59	50	41	-	-	-	-	-			
CA 50-250	65x50	235	18.5	25	79	-	-	-	-	-	-	75.8	74.8	74	71.5	63.5	55.5	47	-	-	-	-			
CA 50-250	65x50	250	22	30	89.5	-	-	-	-	-	-	86	85.3	84	81.5	73.5	63.5	57	-	-	-	-			
CA 50-250	65x50	258	30	40	95.5	-	-	-	-	-	-	92	91.3	90	87.5	79.5	70	63	-	-	-	-			
CA 50-315	65x50	264	30	40	97	-	-	-	-	-	-	94	92	90.5	88	80	72	-	-	-	-	-			
CA 50-315	65x50	284	37	50	114	-	-	-	-	-	-	111	109	107.5	105	97	89	84	-	-	-	-			
CA 50-315	65x50	306	45	60	132	-	-	-	-	-	-	129	127	125.5	123	115	107	102	-	-	-	-			
CA 50-315	65x50	322	55	75	146	-	-	-	-	-	-	143	141	139.5	137	129	121	116	-	-	-	-			
CA 50-315	65x50	340	75	100	164	-	-	-	-	-	-	161	159	157.5	155	147	139	134	-	-	-	-			
CA 65-125	80x65	122	4	5.5	19	-	-	-	-	-	-	-	-	17.3	16.8	14.5	13	11.8	-	-	-	-			
CA 65-125	80x65	132	5.5	7.5	23	-	-	-	-	-	-	-	-	21.3	20.9	19	17.5	16.7	13.7	-	-	-			
CA 65-125	80x65	142	7.5	10	27	-	-	-	-	-	-	-	-	26	25.6	24.5	23	22.5	20	18	-	-			
CA 65-160	80x65	155	9.2	12.5	33	-	-	-	-	-	-	-	-	-	31.5	30	28	27.1	24	21.5	-	-			
CA 65-160	80x65	164	11	15	36	-	-	-	-	-	-	-	-	-	34.5	33	31.5	30.8	28	25.5	-	-			
CA 65-160	80x65	183	15	20	42	-	-	-	-	-	-	-	-	-	41	40	38.5	37.8	35	33	29.5	-			
CA 65-200	80x65	190	15	20	45	-	-	-	-	-	-	-	-	-	45.5	43	41	40.2	36.5	34	-	-			
CA 65-200	80x65	198	18.5	25	52	-	-	-	-	-	-	-	-	-	52.3	51	49	48.2	44.5	42	-	-			
CA 65-200	80x65	212	22	30	59	-	-	-	-	-	-	-	-	-	59.5	58	56	55	52	49.5	44.5	-			
CA 65-250	80x65	225	22	30	64.8	-	-	-	-	-	-	-	-	-	64.7	62	60	58.5	53	50	-	-			
CA 65-250	80x65	244	30	40	80	-	-	-	-	-	-	-	-	-	79.8	77.5	75.5	74.5	70	66	58	-			
CA 65-250	80x65	258	37	50	92	-	-	-	-	-	-	-	-	-	90.5	88.5	87	85	80.5	78	68	-			
CA 65-315	80x65	262	45	60	102	-	-	-	-	-	-	-	-	-	99.2	97	95	94.5	92.4	90	83	-			
CA 65-315	80x65	290	55	75	122	-	-	-	-	-	-	-	-	-	119.2	117.4	115.7	114.5	112.5	110	103	76			
CA 65-315	80x65	317	75	100	141	-	-	-	-	-	-	-	-	-	139.8	137.3	135.6	134.5	132.5	130	122	96			
CA 65-315	80x65	328	90	125	151	-	-	-	-	-	-	-	-	-	149.8	147.3	145.6	144.5	142.5	140	132	106			
CA 80-125	100x80	122	4	5.5	17	-	-	-	-	-	-	-	-	16.5	15.9	14.3	13.5	11.6	10	7.5	-	-			
CA 80-125	100x80	132	5.5	7.5	21	-	-	-	-	-	-	-	-	20.5	20	19	18	16.5	15	12.5	9.5	-			
CA 80-125	100x80	142	7.5	10	26	-	-	-	-	-	-	-	-	25	25	24.5	23.8	22.5	21.5	19.5	16.5	-			

TECHNICAL DATA

50 Hz n=1450 1/min

MODEL	DN mm	Implr Φ mm	Power		Q=DELIVERY																		
			kw	hp	us	0	106	119	132	159	185	198	220	264	317	370	396	423	476	617	661	881	1101
					gpm	0	400	450	500	600	700	750	833	1000	1200	1400	1500	1600	1800	2333	2500	3333	4167
					l/min	0	400	450	500	600	700	750	833	1000	1200	1400	1500	1600	1800	2333	2500	3333	4167
m ³ /h	0	24	27	30	36	42	45	50	60	72	84	90	96	108	140	150	200	250					
					H=Head																		
CA4 65-160	80x65	155	1.1	1.5	8	7.5	7.4	7.3	7	6.6	6.3	5.8	4.8	3.4	-	-	-	-	-	-	-	-	
CA4 65-160	80x65	164	1.5	2	9	8.5	8.4	8.3	8	7.6	7.4	6.9	6	4.6	-	-	-	-	-	-	-	-	
CA4 65-160	80x65	183	2.2	3	10.3	9.9	9.9	9.8	9.5	9.2	9	8.6	7.8	6.5	5	-	-	-	-	-	-	-	
CA4 65-200	80x65	190	1.5	2	10	-	-	9.6	9.1	8.5	8.2	7.6	6.4	4.6	-	-	-	-	-	-	-	-	
CA4 65-200	80x65	198	2.2	3	12.4	-	-	12.2	11.8	11.3	11	10.4	9.3	7.6	-	-	-	-	-	-	-	-	
CA4 65-200	80x65	212	3	4	14.4	-	-	14.3	13.8	13.4	13.1	12.5	11.3	9.6	7.5	-	-	-	-	-	-	-	
CA4 65-250	80x65	225	3	4	15.4	-	-	14.6	13.9	13.1	12.6	11.6	9.7	6.7	-	-	-	-	-	-	-	-	
CA4 65-250	80x65	244	4	5.5	19	-	-	18.3	17.8	17.2	16.9	16.1	14.4	11.7	-	-	-	-	-	-	-	-	
CA4 65-250	80x65	258	5.5	7.5	22.3	-	-	21.3	20.9	20.3	19.9	19.2	17.7	15.1	12	-	-	-	-	-	-	-	
CA4 65-315	80x65	262	4	5.5	18.6	-	-	17.9	17.3	16.7	16.2	15.2	13.3	-	-	-	-	-	-	-	-	-	
CA4 65-315	80x65	280	5.5	7.5	22.1	-	-	-	21.2	20.6	20.2	19.2	17.3	14	-	-	-	-	-	-	-	-	
CA4 65-315	80x65	300	7.5	10	26.5	-	-	-	25.6	25.2	24.9	24.3	23	20.8	17.6	-	-	-	-	-	-	-	
CA4 65-315	80x65	322	11	15	34.8	-	-	-	34.2	33.9	33.7	33.2	32.1	30.2	27.4	25.6	23.7	18.7	-	-	-	-	
CA4 65-315	80x65	328	15	20	40	-	-	-	39.4	39.1	38.9	38.4	37.3	35.4	32.6	30.8	28.9	23.9	-	-	-	-	
CA4 80-160	100x80	168	1.5	2	7.5	-	-	-	-	-	7.1	6.9	6.4	5.5	4.6	4.1	3.5	-	-	-	-	-	
CA4 80-160	100x80	190	2.2	3	9	-	-	-	-	-	8.6	8.4	8	7.4	6.6	6.2	5.7	5	-	-	-	-	
CA4 80-200	100x80	190	3	4	11.8	-	-	-	-	-	11	10.7	10.1	9.2	8	7.3	6.6	-	-	-	-	-	
CA4 80-200	100x80	215	4	5.5	14.2	-	-	-	-	-	13.8	13.6	13.3	12.4	11.3	10.7	10	9	-	-	-	-	
CA4 80-250	100x80	226	4	5.5	17	-	-	-	-	-	16	15.6	14.8	13.2	11.4	10.2	9	-	-	-	-	-	
CA4 80-250	100x80	240	5.5	7.5	20.5	-	-	-	-	-	19.5	19.1	18.4	17.2	15.5	14.5	13.5	11.1	-	-	-	-	
CA4 80-250	100x80	258	7.5	10	24	-	-	-	-	-	23.5	23.2	22.5	21.3	19.9	19	18.1	16	-	-	-	-	
CA4 80-250	100x80	276	11	15	28.2	-	-	-	-	-	27.5	27.2	26.5	25.3	23.9	23	22.1	20	15	-	-	-	
CA4 80-315	100x80	255	5.5	7.5	19.7	-	-	-	-	-	19.1	18.8	18.1	16.8	15	13.9	12.8	10.1	-	-	-	-	
CA4 80-315	100x80	270	7.5	10	24.6	-	-	-	-	-	23.9	23.6	23	21.9	20.4	19.5	18.6	16.3	-	-	-	-	
CA4 80-315	100x80	290	11	15	29.9	-	-	-	-	-	29.4	29.2	28.8	28.1	27	26.3	25.5	23.6	16.5	13.5	-	-	
CA4 80-315	100x80	328	15	20	36.8	-	-	-	-	-	36.4	36.1	35.6	34.7	33.6	33	32.4	30.9	25.3	23	-	-	
CA4 80-400	100x80	335	18.5	25	40.3	-	-	-	-	-	39.7	39.5	39.1	38.4	37.3	36.6	35.9	34.1	27.3	24.5	-	-	
CA4 80-400	100x80	355	22	30	45.1	-	-	-	-	-	44.6	44.5	44.2	43.6	42.6	42	41.4	39.8	33.4	30.7	-	-	
CA4 80-400	100x80	386	30	40	55.1	-	-	-	-	-	54.7	54.6	54.4	54	53.3	52.8	52.2	50.9	45.4	43.2	-	-	
CA4 80-400	100x80	396	37	50	59	-	-	-	-	-	58.7	58.6	58.4	58	57.3	56.8	56.2	54.9	49.4	47.2	37.5	-	
CA4 100-160	125x100	140	2.2	3	5.9	-	-	-	-	-	5.8	5.7	5.5	5.3	5	4.9	4.6	4.3	-	-	-	-	
CA4 100-160	125x100	165	3	4	8.2	-	-	-	-	-	8.1	8	7.9	7.6	7.3	7.2	6.9	6.5	5.1	-	-	-	
CA4 100-160	125x100	190	4	5.5	11.5	-	-	-	-	-	11.5	11.4	11.2	10.9	10.6	10.5	10.2	9.8	8.4	7.8	-	-	
CA4 100-200	125x100	185	4	5.5	11.8	-	-	-	-	-	11.7	11.6	11.4	11	10.5	10.3	9.7	9.1	6.8	5.9	-	-	
CA4 100-200	125x100	195	5.5	7.5	13.3	-	-	-	-	-	13.2	13.2	13	12.7	12.4	12.3	12	11.5	9.6	8.8	5.7	-	
CA4 100-200	125x100	210	5.5	7.5	14.8	-	-	-	-	-	14.7	14.7	14.5	14.2	13.9	13.8	13.5	13	11.1	10.3	7.2	-	
CA4 100-200	125x100	218	9.2	12.5	16.5	-	-	-	-	-	16.4	16.4	16.2	15.9	15.6	15.5	15.2	14.7	12.8	12	8.9	-	
CA4 100-250	125x100	220	5.5	7.5	15.9	-	-	-	-	-	15.8	15.7	15.5	14.9	14.4	14.1	13.4	12.5	9.2	7.9	-	-	
CA4 100-250	125x100	240	7.5	10	19.5	-	-	-	-	-	19.5	19.4	19.2	18.8	18.3	18.1	17.6	16.9	14	12.7	-	-	
CA4 100-250	125x100	257	11	15	24.3	-	-	-	-	-	24.3	24.2	24.1	23.7	23.3	23.1	22.7	22.1	19.7	18.6	11.4	-	
CA4 100-250	125x100	270	15	20	27.8	-	-	-	-	-	27.8	27.7	27.6	27.2	26.8	26.6	26.2	25.6	23.2	22.1	14.9	-	
CA4 100-315	125x100	280	15	20	28	-	-	-	-	-	-	27.8	27.6	27.2	26.9	26.7	26.2	25.6	23.1	22.1	14.9	-	
CA4 100-315	125x100	300	18.5	25	31	-	-	-	-	-	-	30.8	30.6	30.2	29.9	29.7	29.2	28.6	26.1	25.1	17.9	-	
CA4 100-315	125x100	315	22	30	35	-	-	-	-	-	-	34.4	34.2	33.8	33.5	33.3	32.8	32.2	30	29	24	17.3	
CA4 100-315	125x100	328	30	40	37	-	-	-	-	-	-	36.8	36.7	36.4	36.1	35.9	35.5	35.1	33.2	32.4	28	21.3	
CA4 100-400	125x100	358	30	40	46.4	-	-	-	-	-	-	-	46	46	46	46	45	44	42	40	29.6	-	
CA4 100-400	125x100	378	37	50	51.8	-	-	-	-	-	-	-	51.3	51.2	51.1	51	50.5	49.5	47.5	46	37.3	-	
CA4 100-400	125x100	396	45	60	57.1	-	-	-	-	-	-	-	56.7	56.4	56.1	56	56	55	53	52	45	32.1	
CA4 100-400	125x100	420	55	75	64	-	-	-	-	-	-	-	63.7	63.4	63.1	63	63	62	60	59	52	39.1	

TECHNICAL DATA

50 Hz n=1450 1/min

MODEL	DN mm	Implr Φ mm	Power kw hp		Q=DELIVERY																	
					us gpm	0	132	154	176	220	264	396	441	485	617	661	881	1101	1322	1762	2203	2643
					l/min	0	500	583	667	833	1000	1500	1667	1833	2333	2500	3333	4167	5000	6667	8333	10000
					m³/h	0	30	35	40	50	60	90	100	110	140	150	200	250	300	400	500	600
H=Head																						
CA4 125-200	150x125	190	5.5	7.5	11.4	11.1	11.1	11	10.9	10.8	10.2	10	9.7	8.9	8.6	6.9	-	-	-	-		
CA4 125-200	150x125	205	7.5	10	14.1	13.9	13.8	13.8	13.7	13.6	13.1	12.9	12.7	11.9	11.6	9.6	-	-	-	-		
CA4 125-200	150x125	218	11	15	18.1	17.9	17.8	17.8	17.7	17.6	17.1	16.9	16.7	15.9	15.6	13.6	9.8	-	-	-		
CA4 125-250	150x125	215	7.5	10	15.4	-	-	-	-	15.3	15	14.8	14.6	13.6	13.1	-	-	-	-	-		
CA4 125-250	150x125	240	11	15	19.4	-	-	-	-	19.3	19.1	19	18.9	18.1	17.8	15.3	11.7	-	-	-		
CA4 125-250	150x125	265	15	20	23.2	-	-	-	-	23.3	23.1	23	22.9	22	22	19.8	16.5	12.3	-	-		
CA4 125-250	150x125	274	18.5	25	25.6	-	-	-	-	25.5	25.5	25.4	25.3	24.9	24.7	23	20.3	16.5	-	-		
CA4 125-315	150x125	280	18.5	25	27.3	-	-	-	-	-	-	26.9	26.7	25.9	25.6	23.3	19.7	14.9	-	-		
CA4 125-315	150x125	295	22	30	30	-	-	-	-	-	-	29.7	29.6	28.9	28.6	26.5	23.2	18.4	-	-		
CA4 125-315	150x125	310	30	40	35.6	-	-	-	-	-	-	35.4	35.3	34.8	34.6	32.9	30.1	26.1	-	-		
CA4 125-315	150x125	328	37	50	38.2	-	-	-	-	-	-	38	37.9	37.4	37.2	35.7	33.1	29.4	17.8	-		
CA4 125-400	150x125	350	30	40	41	-	-	-	-	-	41	40.5	40.3	39.2	38.6	34.4	27.5	18.3	-	-		
CA4 125-400	150x125	370	37	50	46.2	-	-	-	-	-	46	45.7	45.5	44.6	44.2	40.7	34.8	26.5	-	-		
CA4 125-400	150x125	390	45	60	51.4	-	-	-	-	-	51	50.9	50.8	50.1	49.8	47	42.2	34.8	-	-		
CA4 125-400	150x125	410	55	75	56.5	-	-	-	-	-	56.3	56.3	56.2	55.9	55.7	53.8	50.3	44.7	26.7	-		
CA4 125-400	150x125	425	75	100	64.5	-	-	-	-	-	64.3	64.3	64.2	63.9	63.7	61.8	58.3	52.7	34.7	-		
CA4 125-400	150x125	440	90	125	70	-	-	-	-	-	69.8	69.8	69.7	69.4	69.2	67.3	63.8	58.2	40.2	-		
CA4 150-200	200x150	225	11	15	14	-	-	-	-	-	-	-	13.5	13.4	13.3	13.1	12.9	11.7	7.8	-		
CA4 150-200	200x150	240	15	20	16.3	-	-	-	-	-	-	-	15.5	15.3	15.2	14.8	14.3	13.5	11.1	-		
CA4 150-200	200x150	250	18.5	25	18.3	-	-	-	-	-	-	-	17.5	17.3	17.2	16.8	16.3	15.5	13.1	10		
CA4 150-200	200x150	258	22	30	20.3	-	-	-	-	-	-	-	19.5	19.3	19.2	18.8	18.3	17.5	15.1	12		
CA4 150-250	200x150	242	15	20	17.5	-	-	-	-	-	-	-	-	-	16.8	15.9	14.7	13.2	9.2	-		
CA4 150-250	200x150	265	18.5	25	21.3	-	-	-	-	-	-	-	-	-	20.8	20	18.9	17.5	13.8	8.7		
CA4 150-250	200x150	280	22	30	24	-	-	-	-	-	-	-	-	-	23.6	23	22	20.8	17.1	12		
CA4 150-250	200x150	295	30	40	25.5	-	-	-	-	-	-	-	-	-	25	24.5	23.5	22	18.8	13.8		
CA4 150-315	200x150	287	30	40	30.2	-	-	-	-	-	-	-	-	-	29.7	29	27.9	26.4	22.3	-		
CA4 150-315	200x150	305	37	50	33.6	-	-	-	-	-	-	-	-	-	33.5	32.7	31.7	30.4	26.7	21.4		
CA4 150-315	200x150	327	45	60	37.7	-	-	-	-	-	-	-	-	-	37.6	36.9	35.9	34.7	31.3	26.5		
CA4 150-315	200x150	340	55	75	40	-	-	-	-	-	-	-	-	-	40	39.3	38.4	37.2	33.9	29.4		
CA4 150-315	200x150	365	75	100	47	-	-	-	-	-	-	-	-	-	47	46.3	45.4	44.2	40.9	36.4		
CA4 150-400	200x150	360	55	75	48.2	-	-	-	-	-	-	-	-	47.7	48	46	45	42	36.8	29.2		
CA4 150-400	200x150	385	75	100	55.4	-	-	-	-	-	-	-	-	55	55	54	53	51	47	41		
CA4 150-400	200x150	400	90	125	59.5	-	-	-	-	-	-	-	-	59	59	58	57	56	52	46		
CA4 150-400	200x150	420	110	150	65.5	-	-	-	-	-	-	-	-	65	65	64	63	62	58	52		
CA4 150-400	200x150	440	132	180	72	-	-	-	-	-	-	-	-	71.5	71.5	70.5	69.5	68.5	64.5	58.5		

MODEL	DN mm	Implr Φ mm	Power kw hp		Q=DELIVERY																
					us gpm	0	881	1322	1762	2203	2643	3084	3524	3965	4405	4846	52	86	5727	6167	6608
					l/min	0	3333	5000	6667	8333	10000	11667	13333	15000	16667	18333	20000	21667	23333	25000	
					m³/h	0	200	300	400	500	600	700	800	900	1000	1100	1200	1300	1400	1500	
H=Head																					
CA4 200-250	250x200	270	37	50	23	22	21	19.8	18.3	16.1	12.8	9.3	-	-	-	-	-	-	-	-	
CA4 200-250	250x200	290	45	60	26	25	24	22.8	21.3	19.1	15.8	12.3	-	-	-	-	-	-	-	-	
CA4 200-250	250x200	310	55	75	30.7	29.7	28.7	27.5	26	23.8	20.5	17	-	-	-	-	-	-	-	-	
CA4 200-315	250x200	310	55	75	31.1	31	30	29.3	27.5	25	21.3	16	-	-	-	-	-	-	-	-	
CA4 200-315	250x200	330	75	100	35.1	35	34	33.3	31.5	29	25.3	20	-	-	-	-	-	-	-	-	
CA4 200-315	250x200	360	90	125	42.1	42	41	40.3	38.5	36	32.3	27	-	-	-	-	-	-	-	-	
CA4 200-400	250x200	350	75	100	41	40.9	40.4	38.9	37.4	34.9	32.9	28.9	-	-	-	-	-	-	-	-	
CA4 200-400	250x200	370	90	125	46.5	46.4	45.9	44.4	42.9	40.4	38.4	34.4	-	-	-	-	-	-	-	-	
CA4 200-400	250x200	395	110	150	52.4	52.3	51.8	50.3	48.8	46.3	44.3	40.3	-	-	-	-	-	-	-	-	
CA4 200-400	250x200	420	132	180	60.1	60	59.5	58	56.5	54	52	48	40	-	-	-	-	-	-	-	
CA4 250-315	300x250	320	90	125	30.5	-	-	29	28.3	28	27.6	27	26.4	25.8	24.8	23	21.8	-	-	-	
CA4 250-315	300x250	340	110	150	34.5	-	-	33	32.3	32	31.6	31	30.4	29.8	28.8	27	25.8	-	-	-	
CA4 250-315	300x250	360	132	180	38.5	-	-	37	36.3	36	35.6	35	34.4	33.8	32.8	31	29.8	28	-	-	
CA4 250-315	300x250	390	160	220	45	-	-	43.5	42.8	42.5	42.1	41.5	40.9	40.3	39.3	37.5	36.3	34.5	-	-	
CA4 250-400	300x250	365	160	220	43	-	-	42	41.2	40.8	40	39	38	37	36	34	32.5	30	-	-	
CA4 250-400	300x250	380	185	250	47	-	-	46	45.2	44.8	44	43	42	41	40	38	36.5	34	-	-	
CA4 250-400	300x250	400	200	270	53	-	-	52	51.2	50.8	50	49	48	47	46	44	42.5	40	38	-	
CA4 250-400	300x250	420	220	300	58	-	-	57	56.2	55.8	55	54	53	52	51	49	47.5	45	43	-	
CA4 250-400	300x250	448	250	340	66	-	-	65	64.2	63.8	63	62	61	60	59	57	55.5	53	51	-	

MATERIAL DESCRIPTION

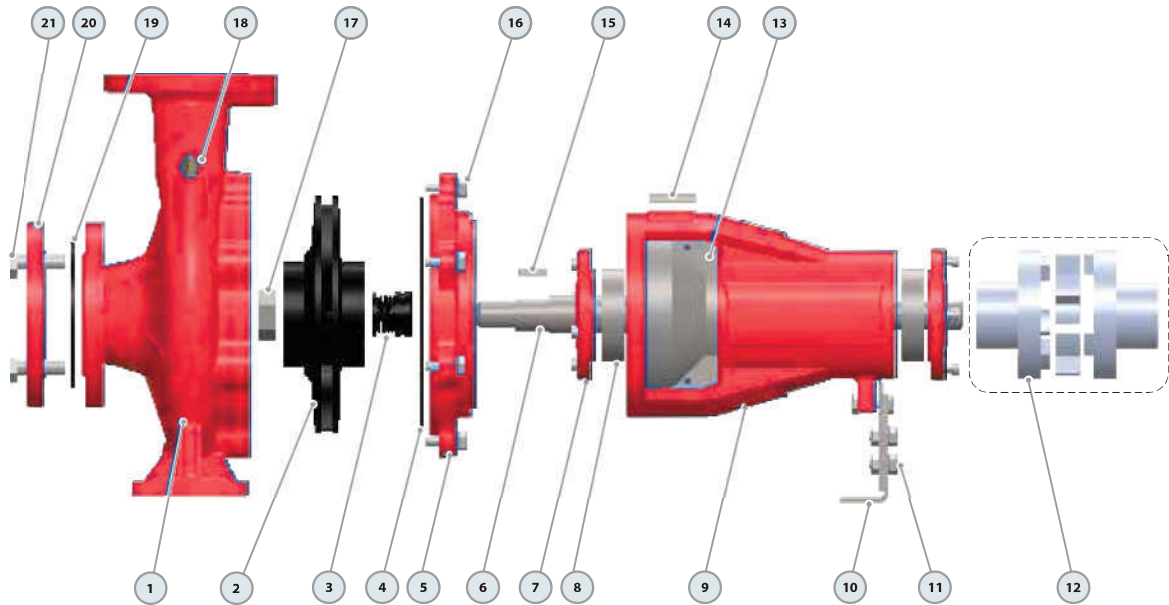

No.	Description	Material	No.	Description	Material	No.	Description	Material
1	Pump Case	Cast iron	8	Bearing	Ball Bearing	15	Impeller Key	Iron
2	Impeller	SS304/Cast iron	9	Support Case	Cast iron	16	Connection Bolt	Steel
3	Mechanical Seal	SiC/Carbon/SS304	10	Support Foot	Iron	17	Impeller Nut	Galvanized Steel
4	O-ring	Rubber	11	Foot Bolt	Steel	18	Release Valve	Brass
5	Connection	Cast iron	12	Coupling(Optional)	Steel	19	Gasket	Rubber
6	Shaft	SS304/45# Steel	13	Case Cover	SS304	20	Counter Flange	Galvanized Cast iron
7	Bearing Cover	Cast iron	14	Nameplate	Aluminum	21	Flange Bolt	Steel

DIMENSIONS AND WEIGHT

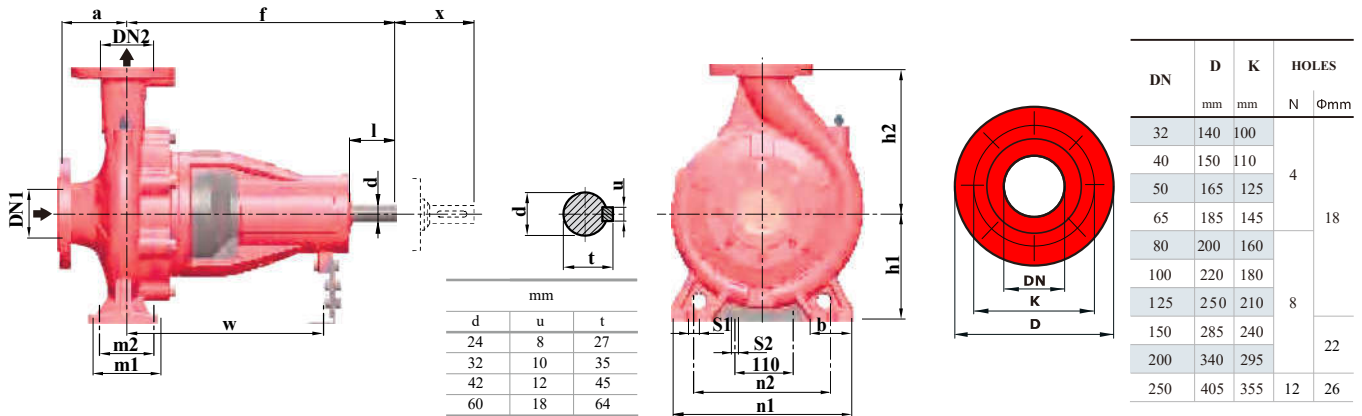

MODEL	DIMENSIONS																kg	
	DN1	DN2	a	f	h1	h2	b	m1	m2	n1	n2	s1	s2	w	x	d		l
32-160	50	32	80	360	132	160	55	95	70	240	190	14	14	260	100	24	50	31
32-200	50	32	80	360	160	180	55	95	70	240	190	14	14	260	100	24	50	35
32-250	50	32	80	360	160	180	55	95	70	240	190	14	14	260	100	24	50	35
40-160	65	40	80	360	132	160	50	100	70	240	190	14	14	260	100	24	50	35
40-200	65	40	100	360	160	180	55	100	70	265	212	14	14	260	100	24	50	38
40-250	65	40	100	360	180	225	65	125	95	320	250	14	14	260	100	24	50	58
40-315	65	40	125	500	200	160	65	125	95	345	280	14	14	370	140	32	80	82
50-125	65	50	100	360	132	180	50	100	70	240	190	14	14	260	100	24	50	30
50-160	65	50	100	360	160	200	55	100	70	265	212	14	14	260	100	24	50	35
50-200	65	50	100	360	160	225	50	100	70	265	212	14	14	260	100	24	50	45
50-250	65	50	100	360	180	180	65	125	95	320	250	14	14	260	100	24	50	50
50-315	65	50	125	500	225	280	65	125	95	345	280	14	14	370	140	32	80	90
65-125	80	65	100	360	160	250	65	125	95	280	212	14	14	260	100	24	50	42
65-160	80	65	100	360	160	200	65	125	95	280	212	14	14	260	100	24	50	45
65-200	80	65	100	360	180	225	65	125	95	320	250	14	14	260	140	24	50	50
65-250	80	65	100	470	200	250	80	160	120	360	280	18	14	340	140	32	80	71
65-315	80	65	125	470	225	280	80	160	120	360	280	18	14	340	140	32	80	98
80-125	100	80	100	360	180	225	65	125	95	320	250	14	14	260	140	24	50	46
80-160	100	80	100	360	180	225	65	125	95	345	250	14	14	260	140	24	50	48
80-200	100	80	100	470	200	250	65	125	95	345	280	14	14	340	140	32	80	65
80-250	100	80	100	470	200	280	80	160	120	400	315	18	14	340	140	32	80	79
80-315	100	80	125	470	250	315	80	160	120	400	315	18	14	340	140	24	50	118
80-400	100	80	125	540	280	355	80	160	120	400	315	18	14	340	140	32	80	150
100-160	125	100	125	360	200	280	80	160	120	360	280	18	14	260	140	32	80	55
100-200	125	100	125	470	200	280	80	160	120	360	280	18	14	340	140	32	80	75
100-250	125	100	125	470	225	280	80	160	120	400	315	18	14	340	140	32	80	88
100-315	125	100	140	470	250	315	80	160	120	400	315	19	14	340	140	32	80	116
100-400	125	100	140	530	280	355	100	200	150	500	400	23	14	370	140	42	110	178
125-200	150	125	140	470	250	315	80	160	120	400	315	19	14	340	140	32	80	112
125-250	150	125	140	470	250	355	80	160	120	400	315	19	14	340	140	32	80	112
125-250H	150	125	140	530	250	355	80	160	120	400	315	19	14	370	140	42	110	140
125-315	150	125	140	530	280	355	100	200	150	500	400	23	14	370	140	42	110	152
125-400	150	125	140	530	315	400	100	200	150	500	400	23	14	370	140	42	110	200
150-200	200	150	160	470	280	400	100	200	150	550	450	23	14	370	140	32	80	166
150-250	200	150	160	530	280	400	100	200	150	550	450	23	14	370	140	42	110	180
150-315	200	150	160	530	280	400	100	200	150	550	450	23	14	370	140	42	110	186
150-400	200	150	160	530	315	450	100	200	150	550	450	23	14	370	140	42	110	228
200-250	250	200	180	530	355	475	100	200	150	550	450	23	14	370	200	42	110	230
200-315	250	200	180	530	355	450	100	200	150	550	450	23	14	370	200	42	110	234
200-400	250	200	180	770	400	500	110	300	250	710	600	28	14	525	250	60	140	363
250-315	300	250	250	530	400	500	110	300	250	710	600	28	14	525	250	42	110	316
250-400	300	250	250	770	400	560	110	300	250	710	600	28	14	525	250	60	140	400

32-160

2900rpm

PERFORMANCE CURVE

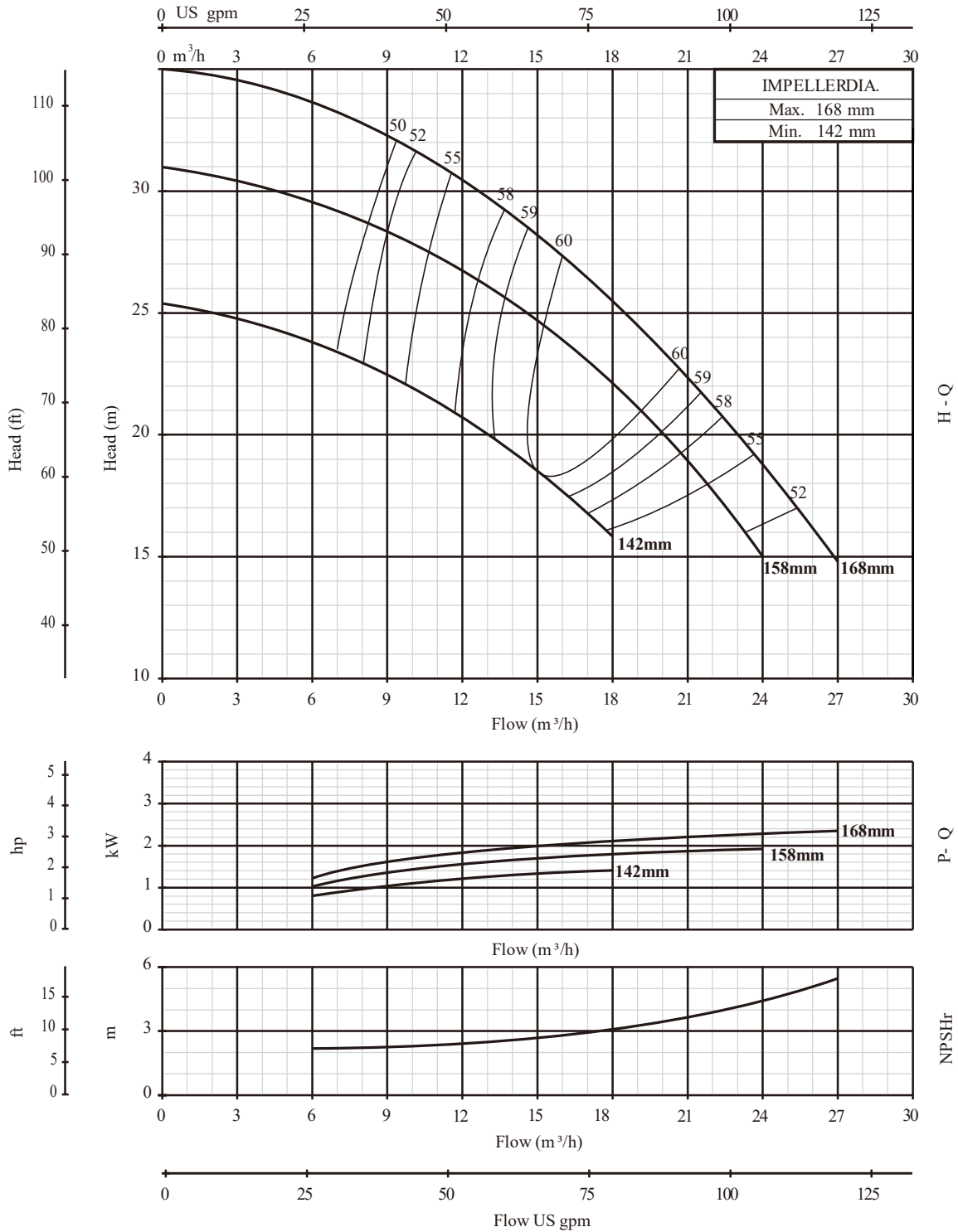

32-200

2900rpm

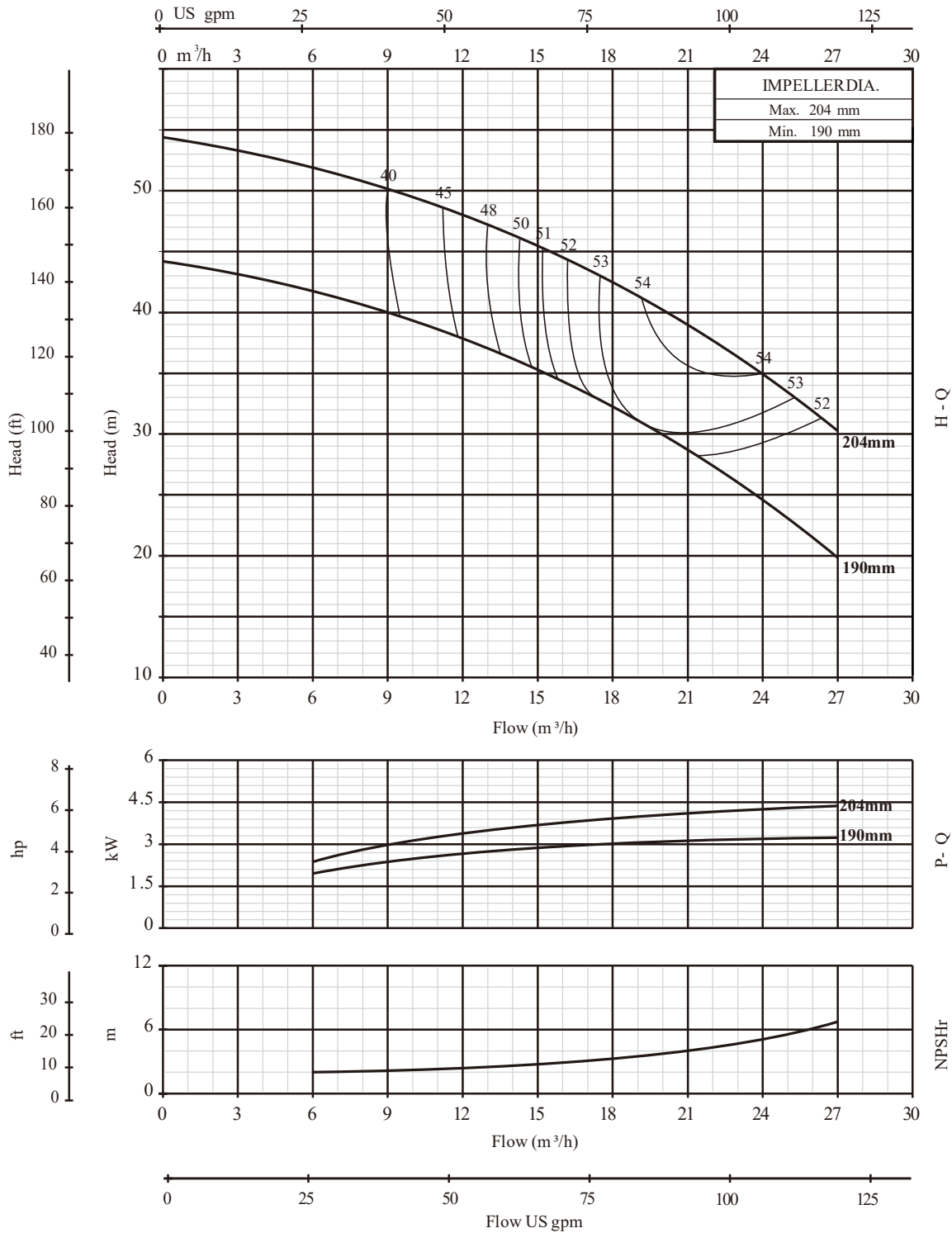

PERFORMANCE CURVE

32-250

2900rpm

PERFORMANCE CURVE

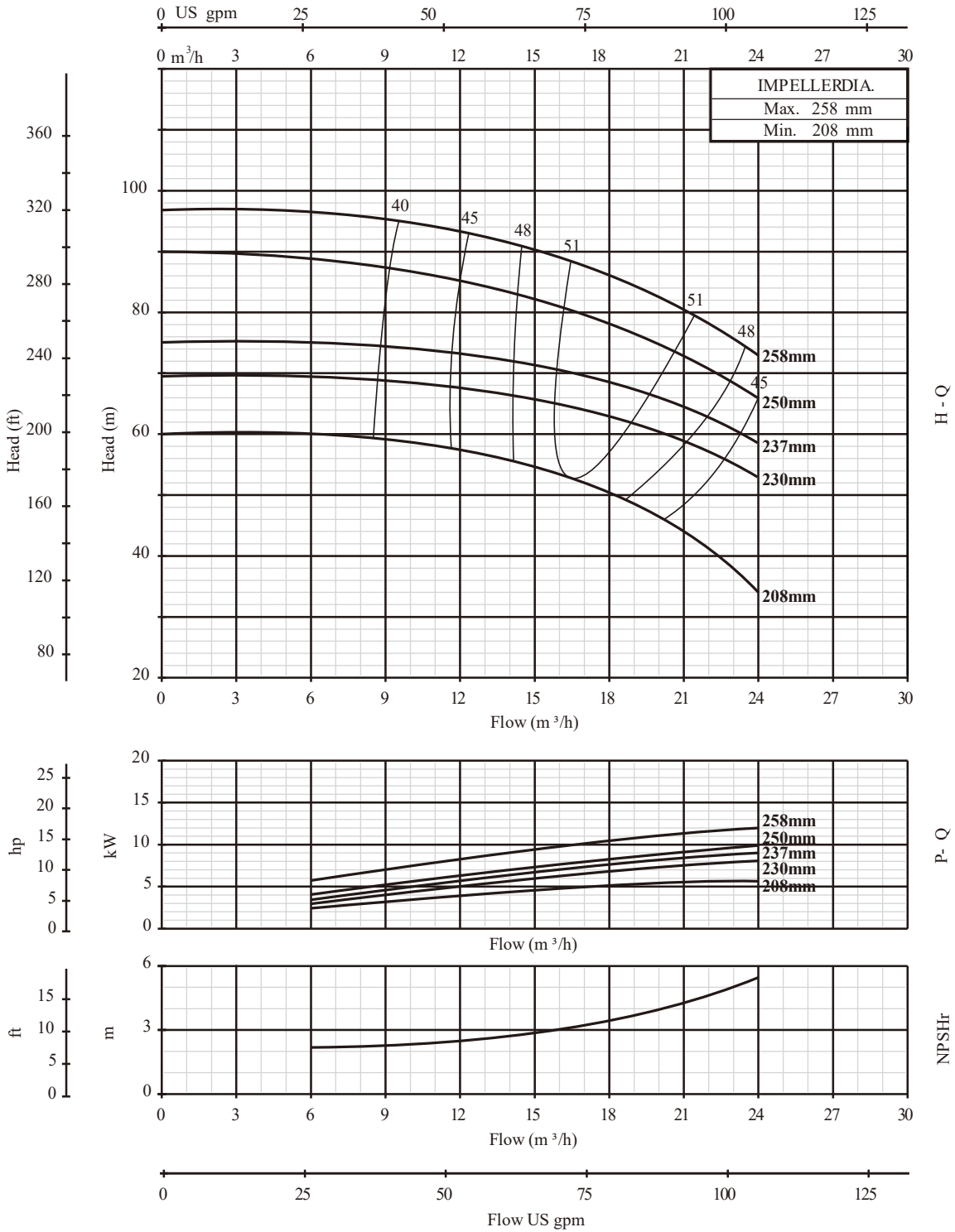

40-160

2900rpm

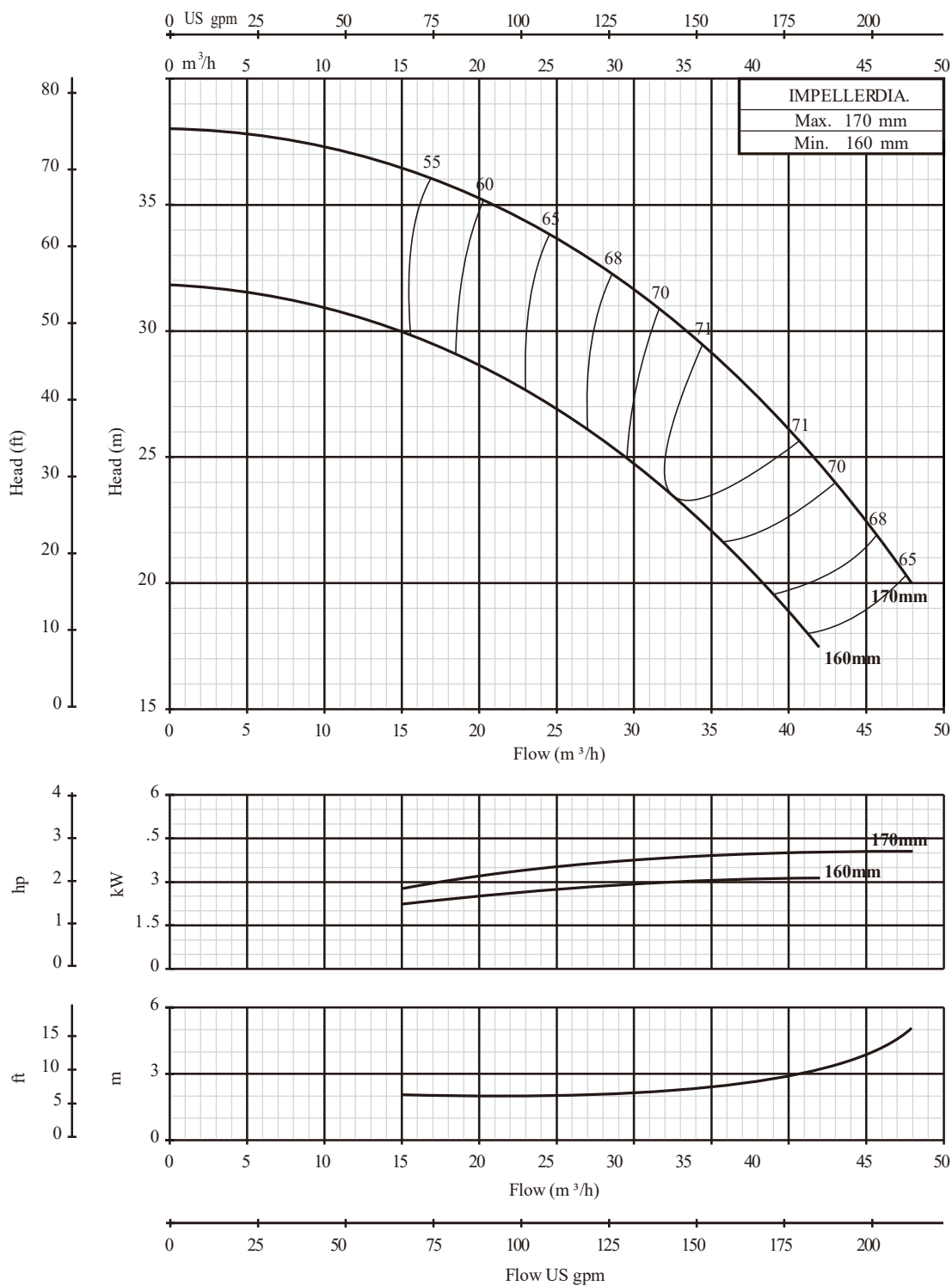

PERFORMANCE CURVE

40-200

2900rpm

PERFORMANCE CURVE

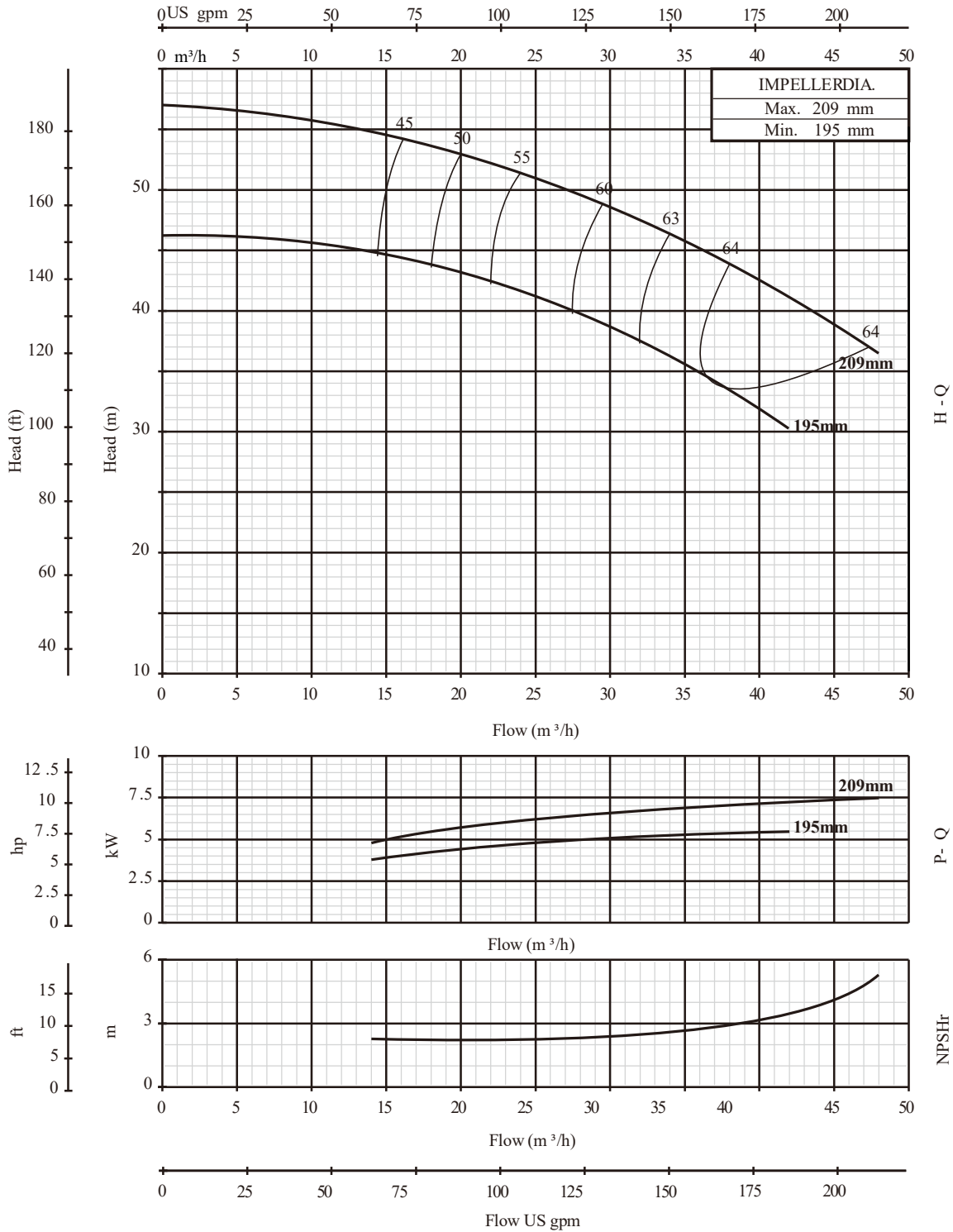

40-250

2900rpm

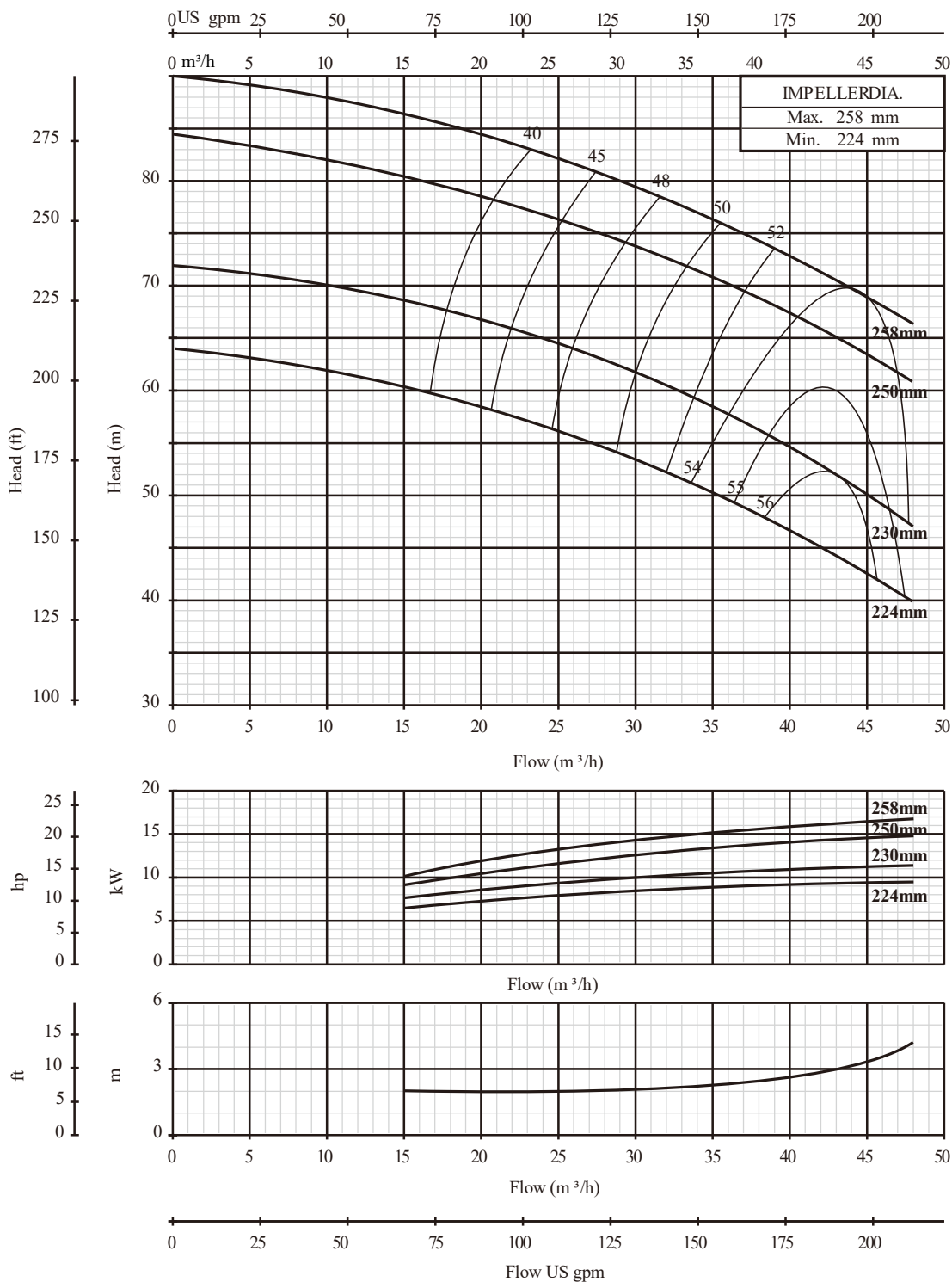

PERFORMANCE CURVE

40-315

2900rpm

PERFORMANCE CURVE

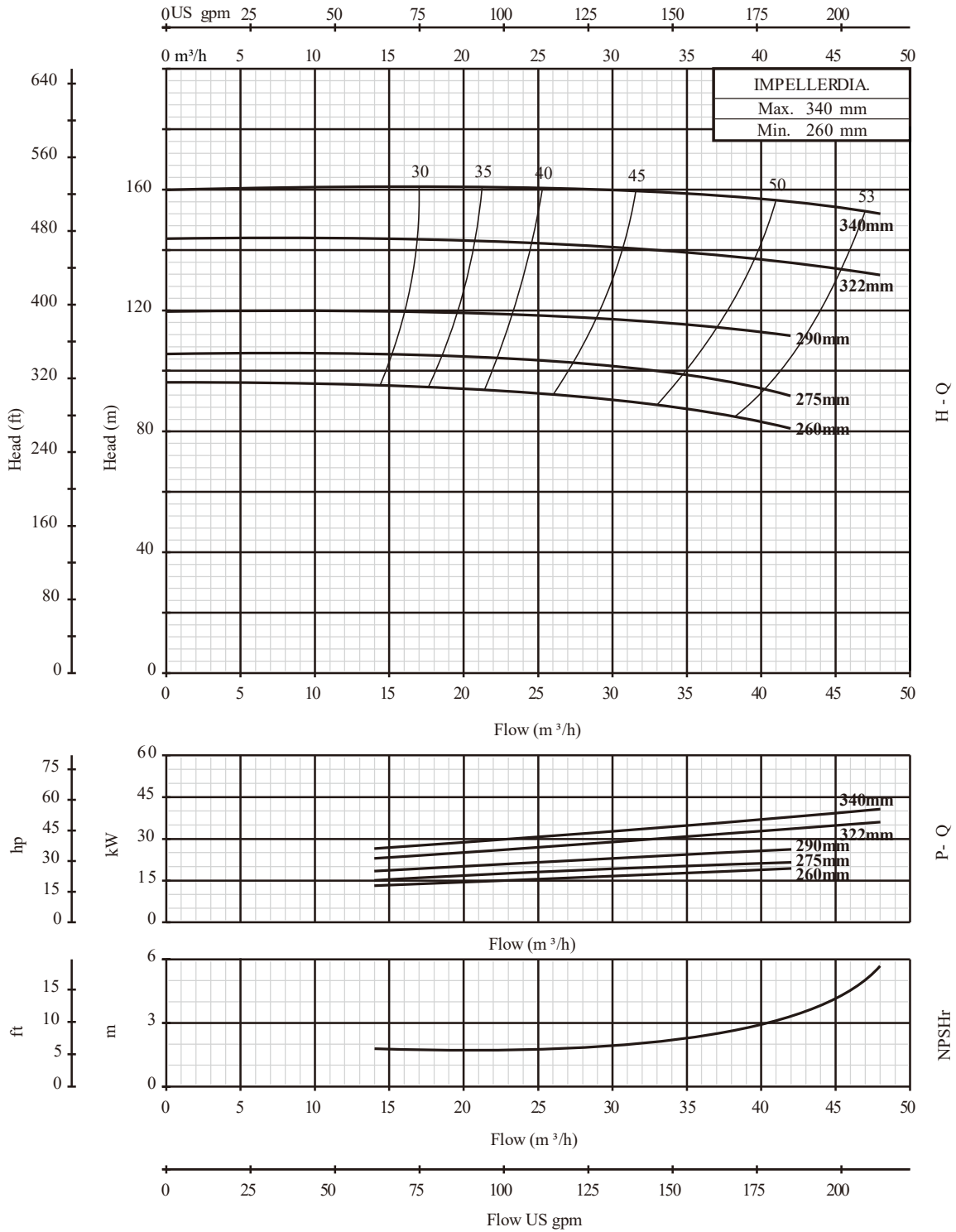

50-125

2900rpm

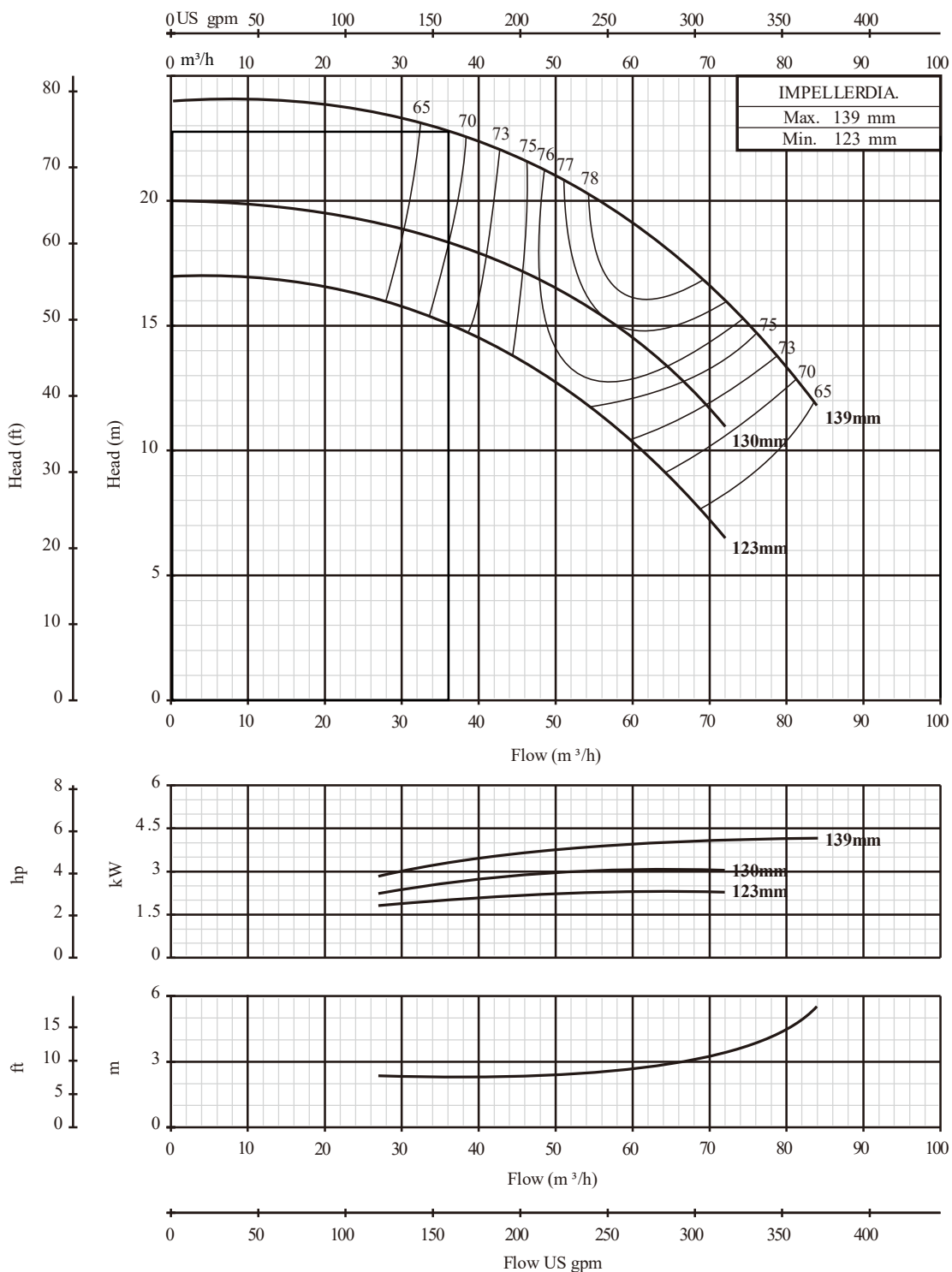

H - Q

P - Q

NPSHr

PERFORMANCE CURVE

50-160

2900rpm

PERFORMANCE CURVE

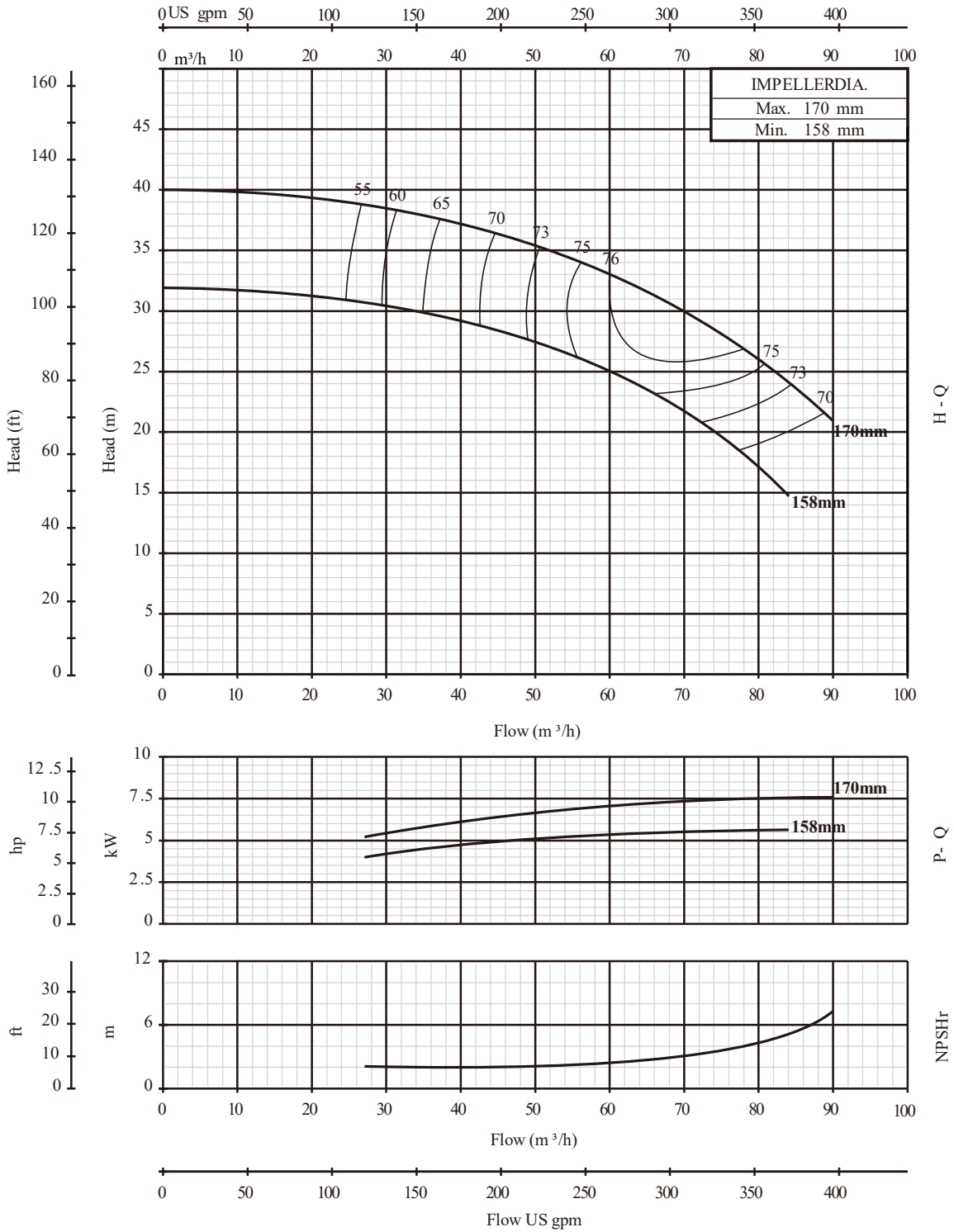

50-200

2900rpm

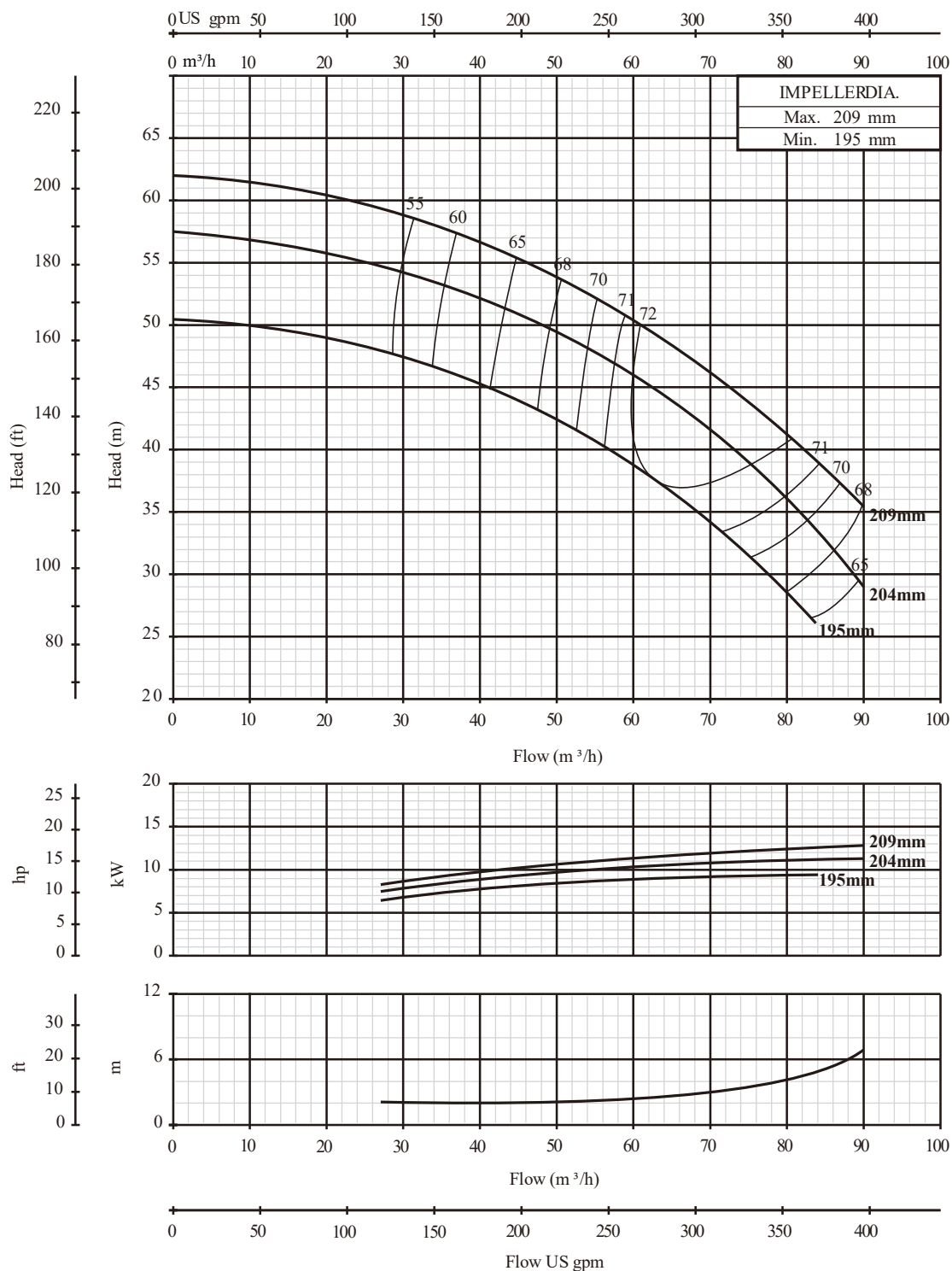

PERFORMANCE CURVE

50-250

2900rpm

PERFORMANCE CURVE

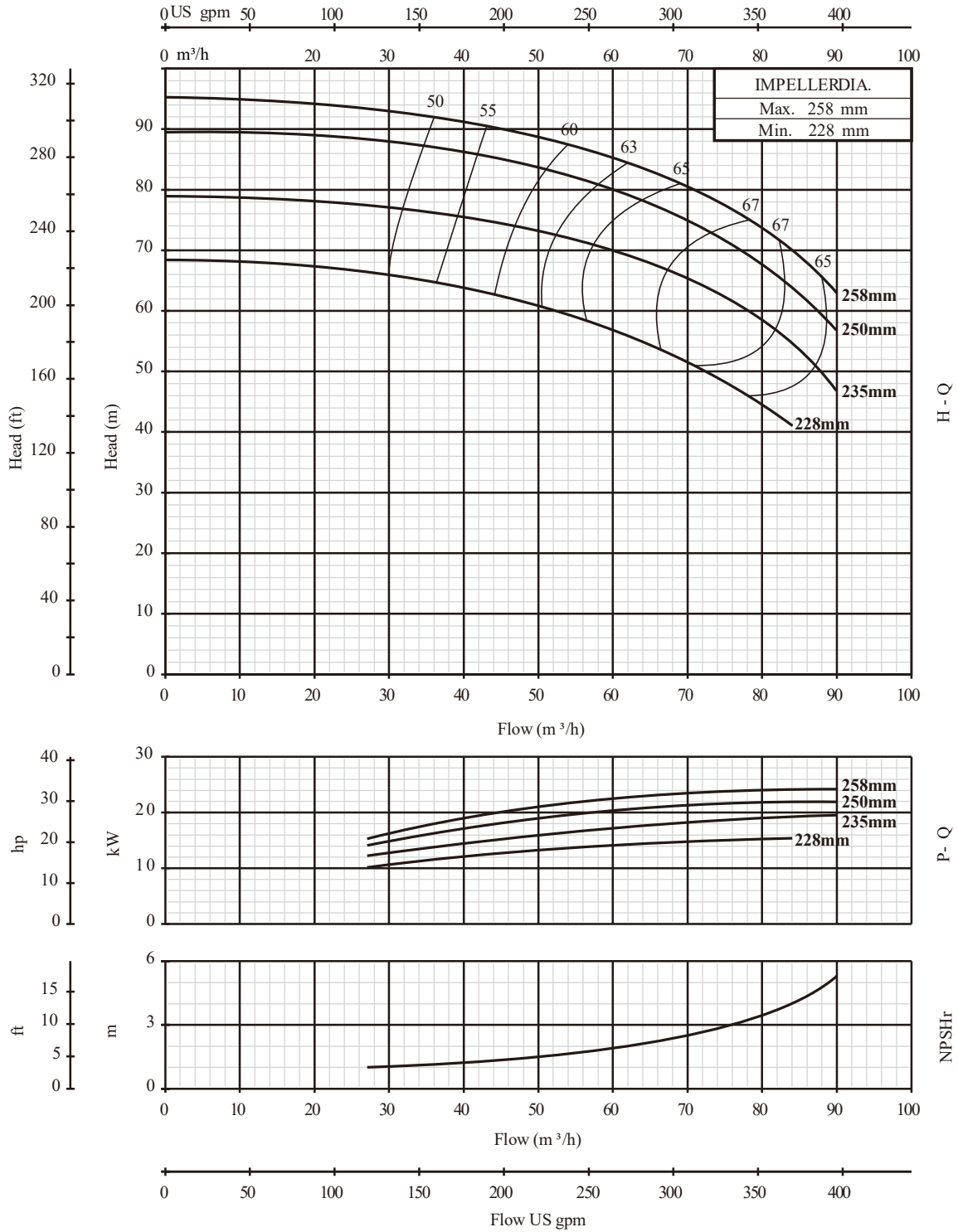

50-315

2900rpm

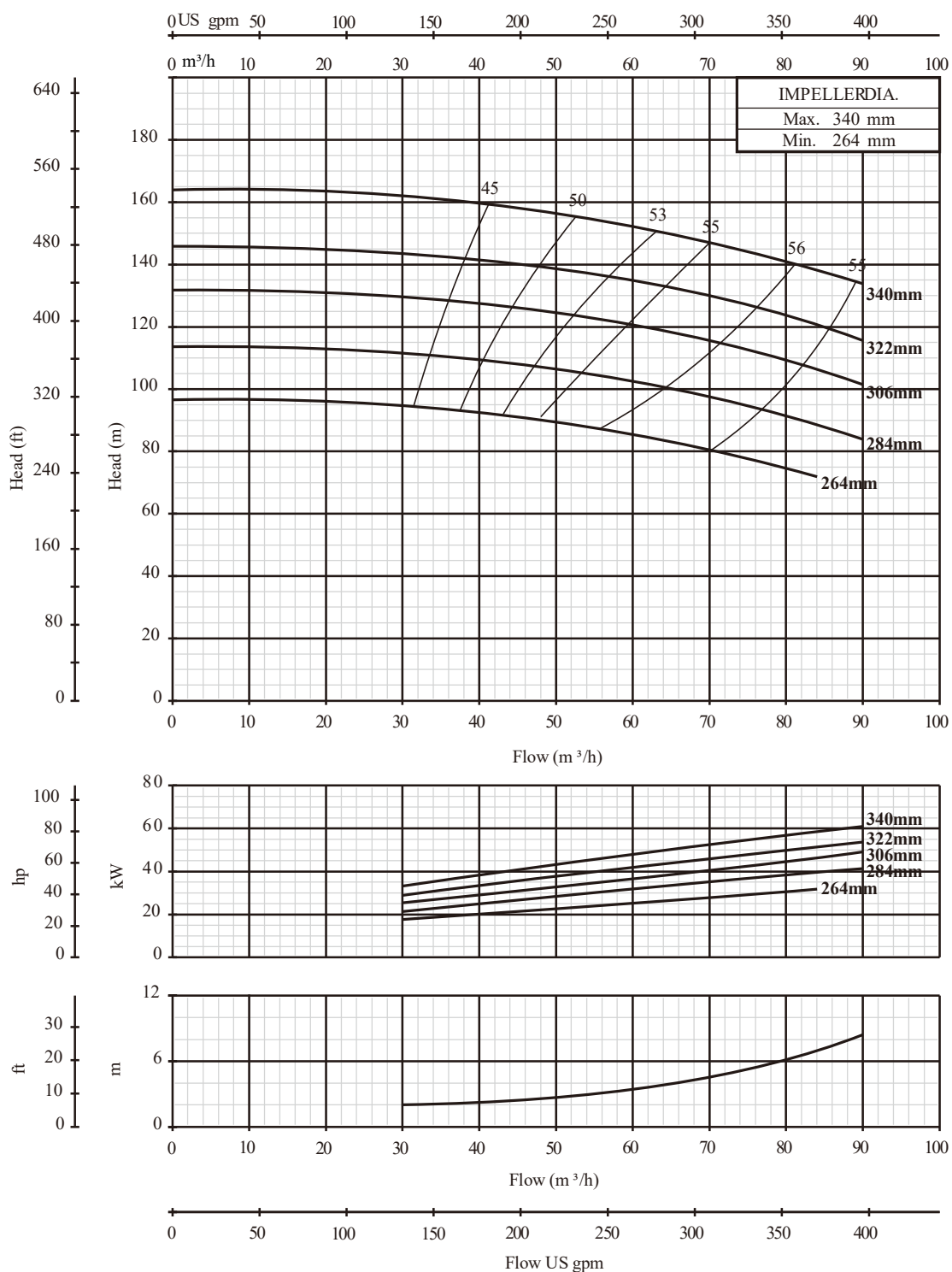

PERFORMANCE CURVE

65-125

2900rpm

PERFORMANCE CURVE

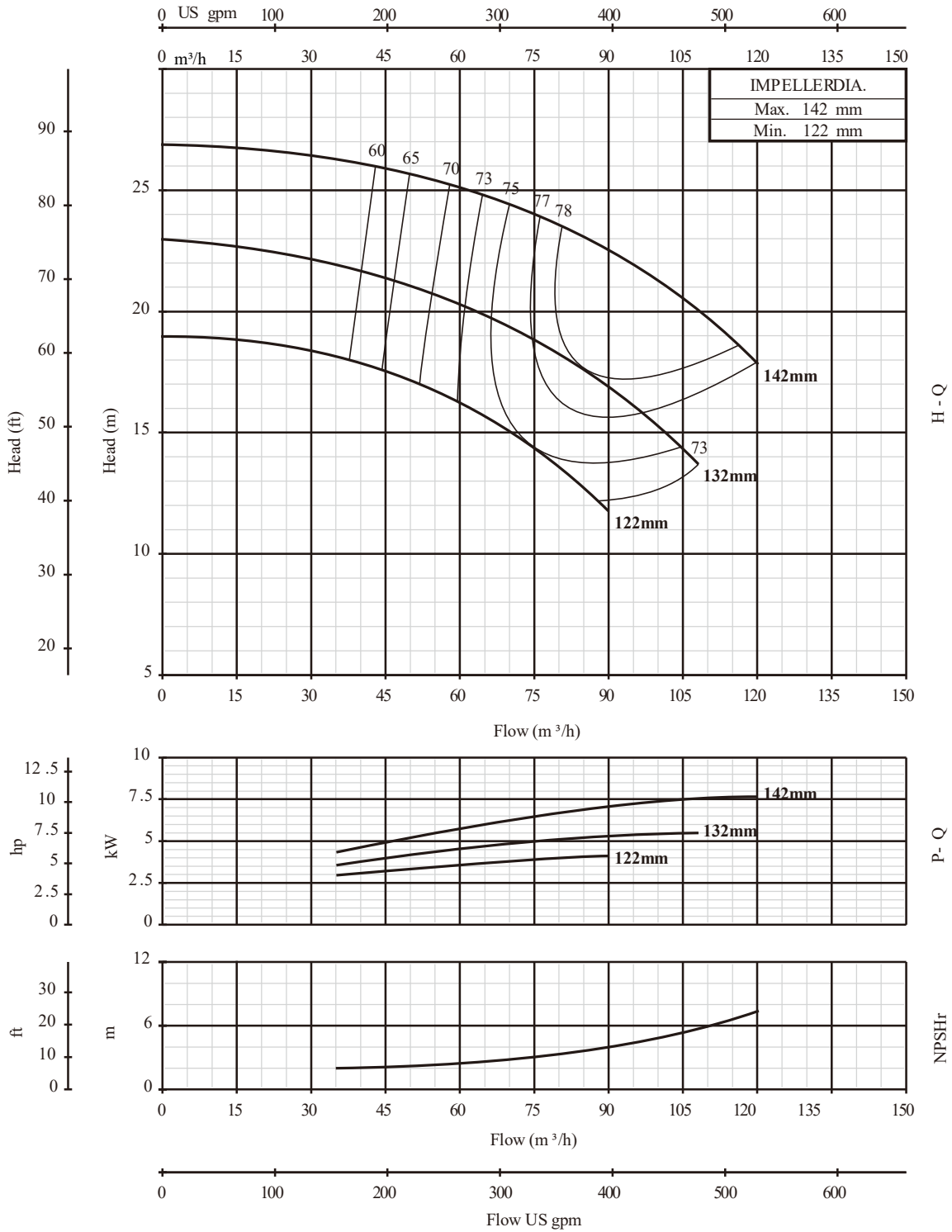

65-160

2900rpm

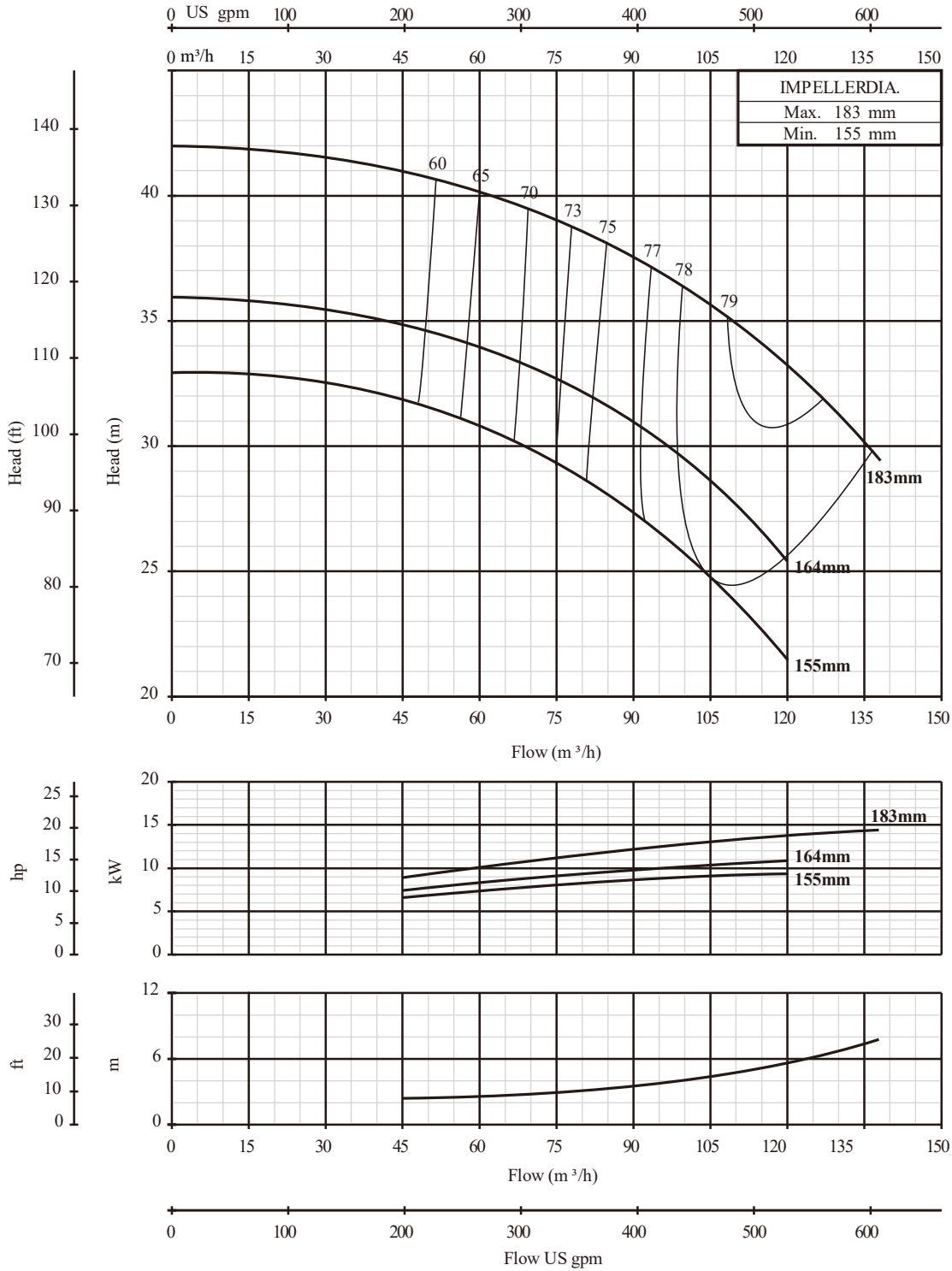

H - Q

P - Q

NPSHr

PERFORMANCE CURVE

65-200

2900rpm

PERFORMANCE CURVE

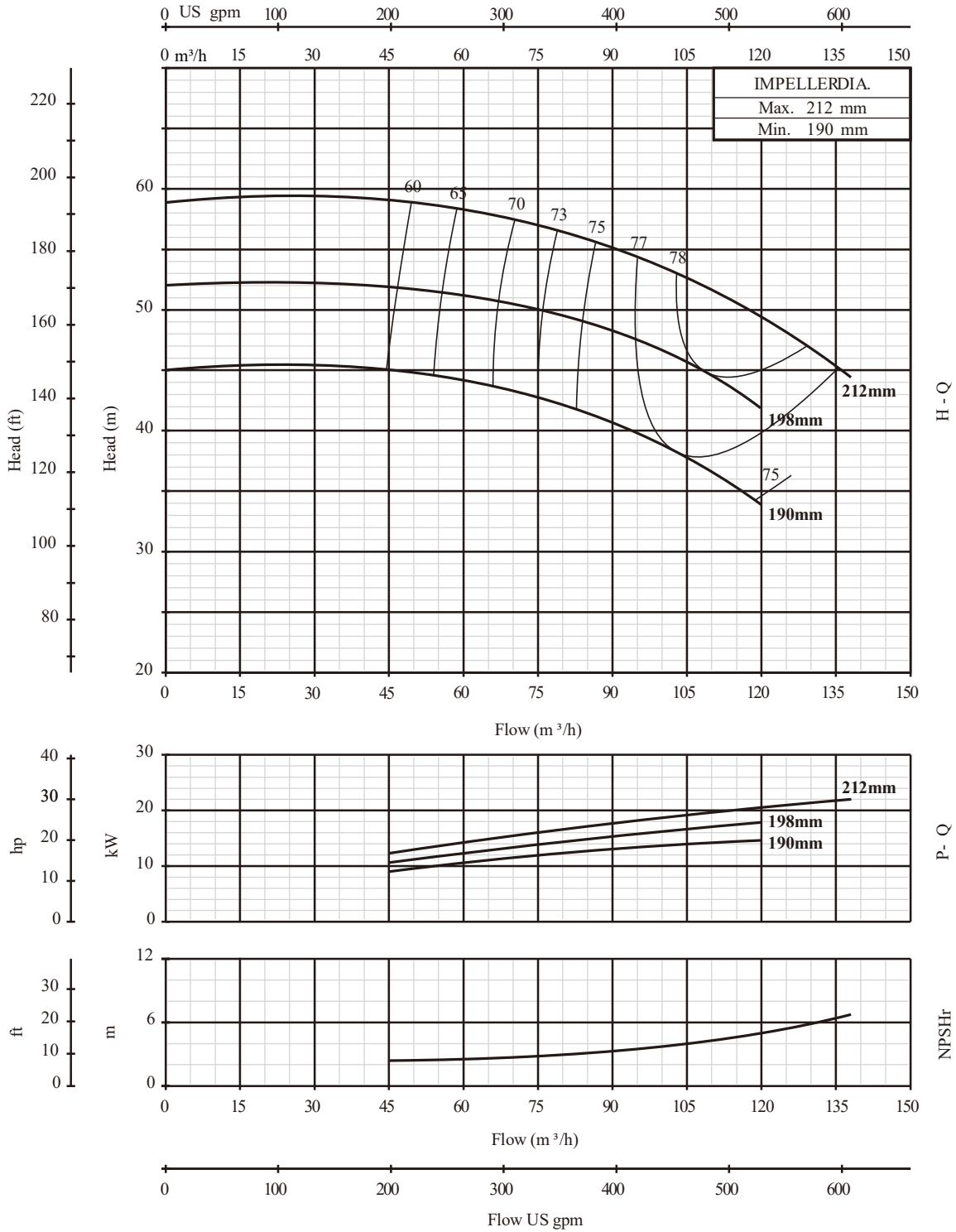

65-250

2900rpm

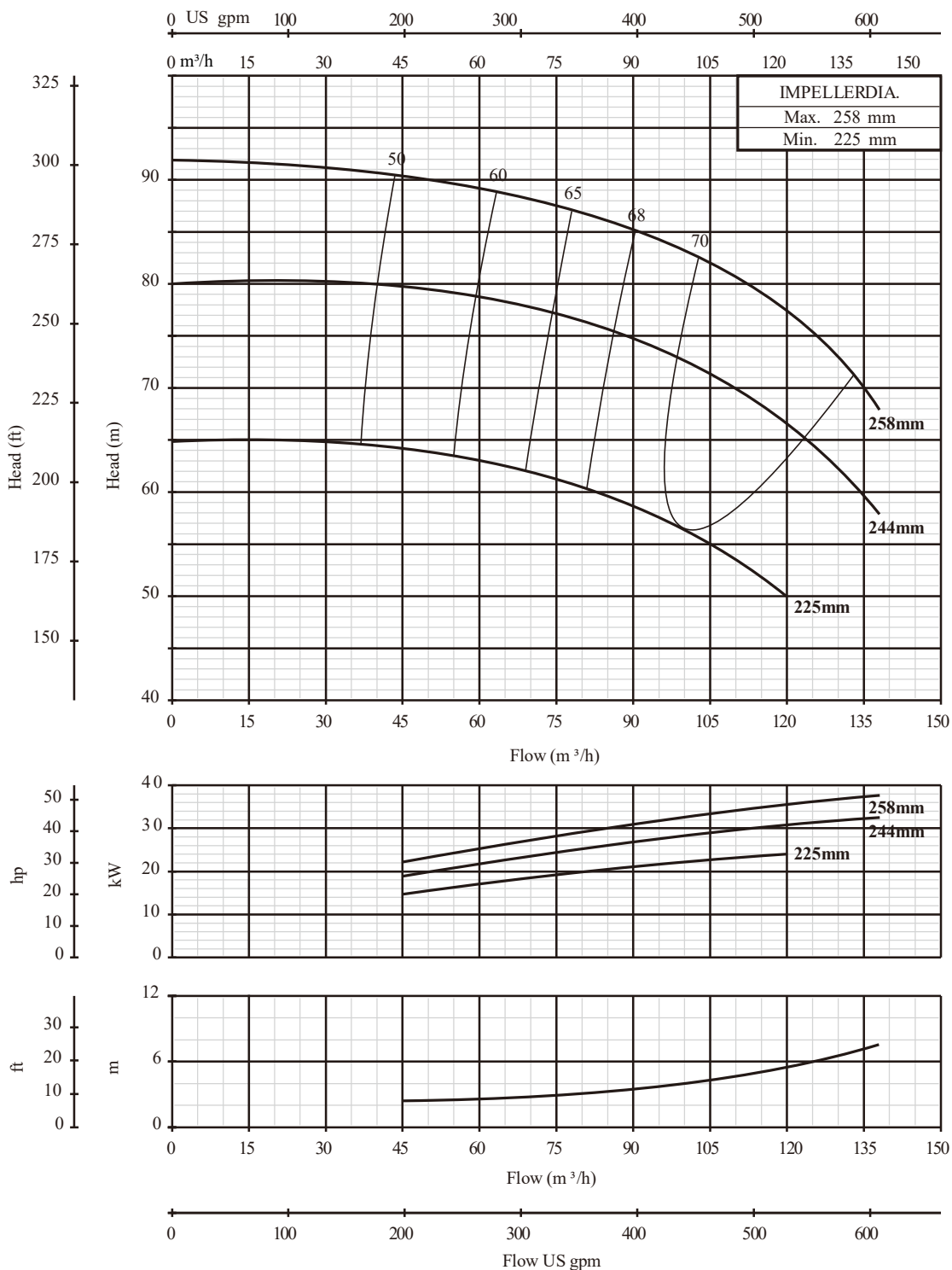

H - Q

P - Q

NPSHr

PERFORMANCE CURVE

65-315

2900rpm

PERFORMANCE CURVE

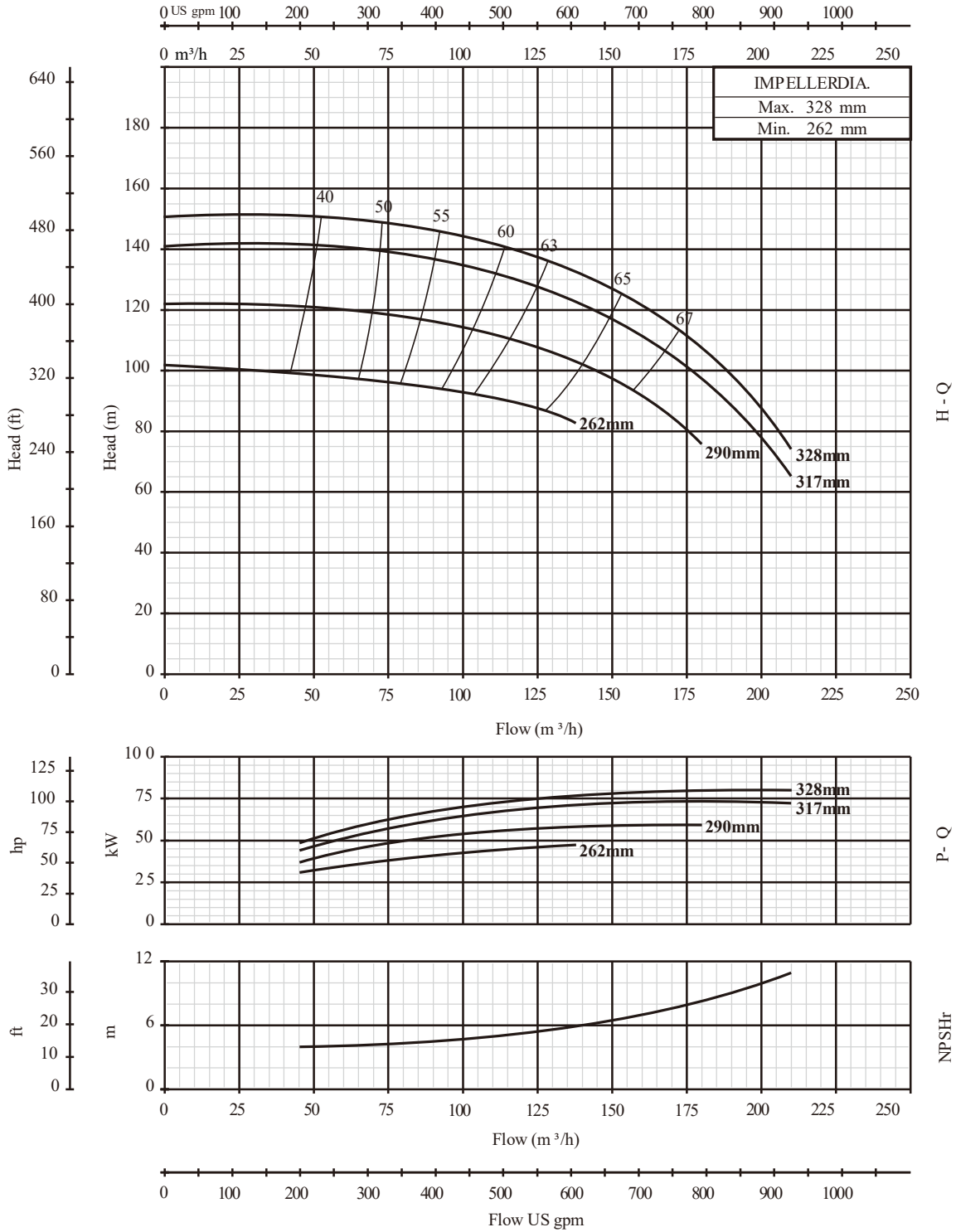

80-125

2900rpm

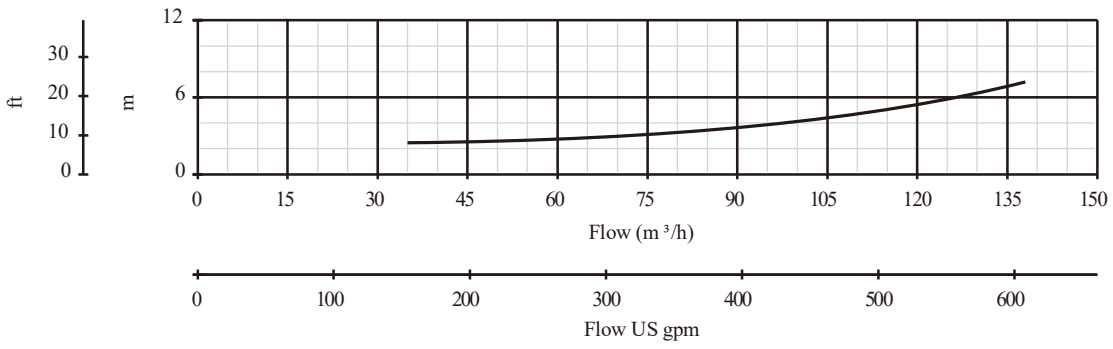
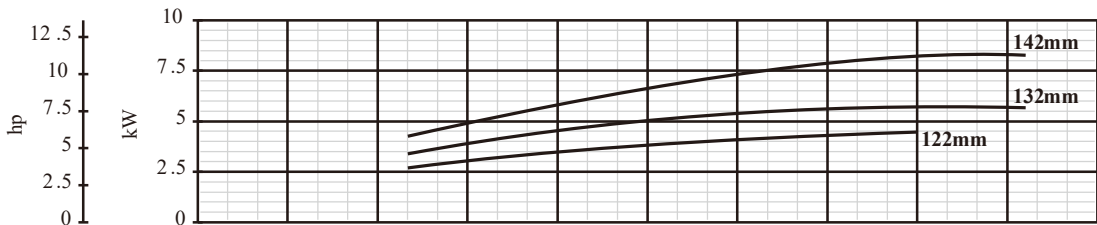
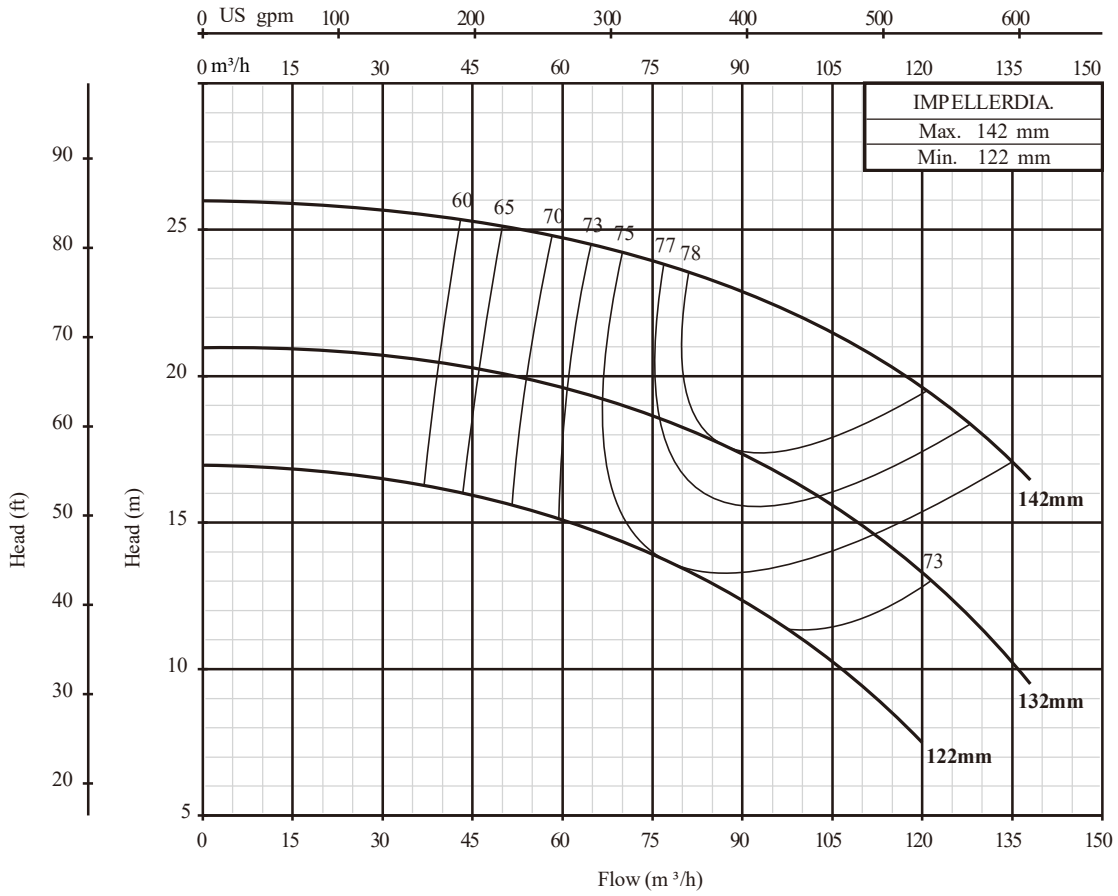

H - Q

P - Q

NPSHr

PERFORMANCE CURVE

80-160

2900rpm

PERFORMANCE CURVE

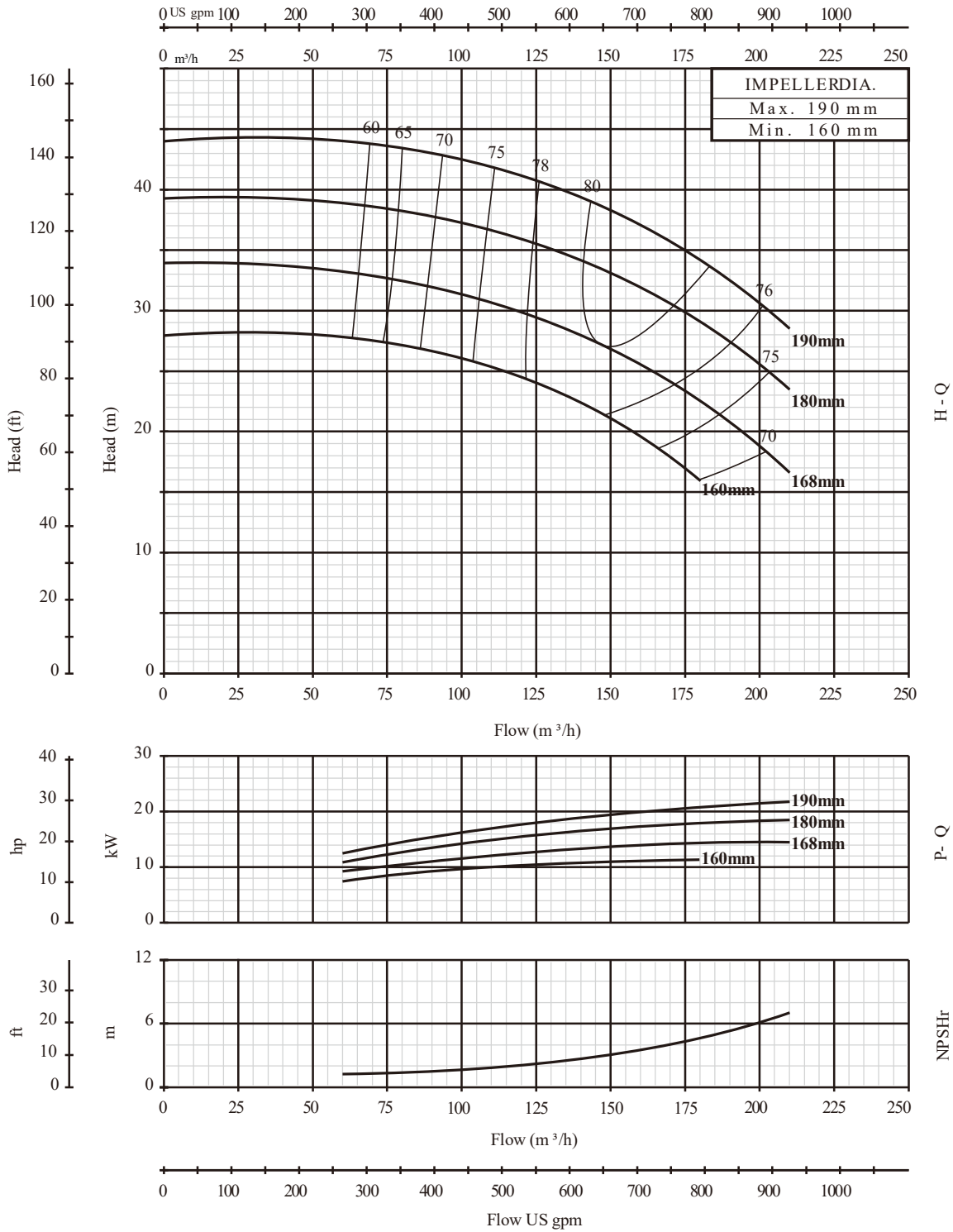

80-200

2900rpm

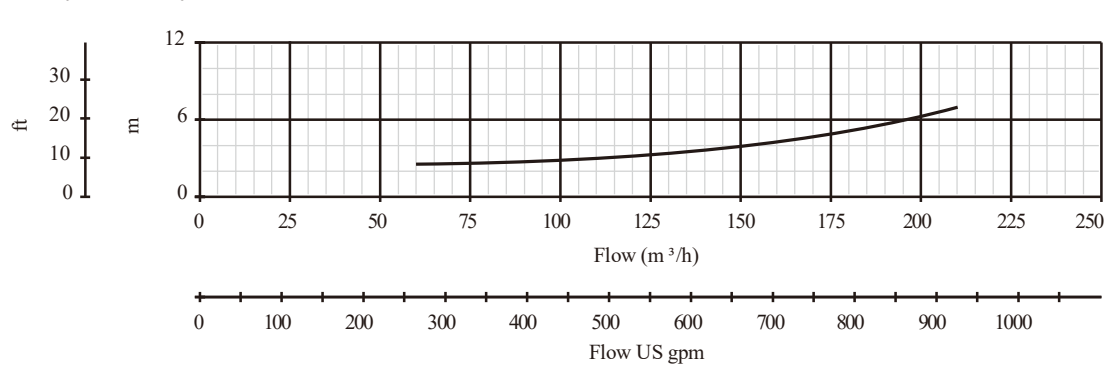
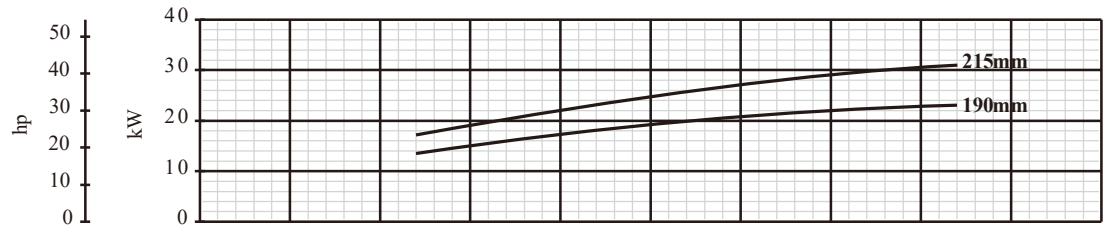
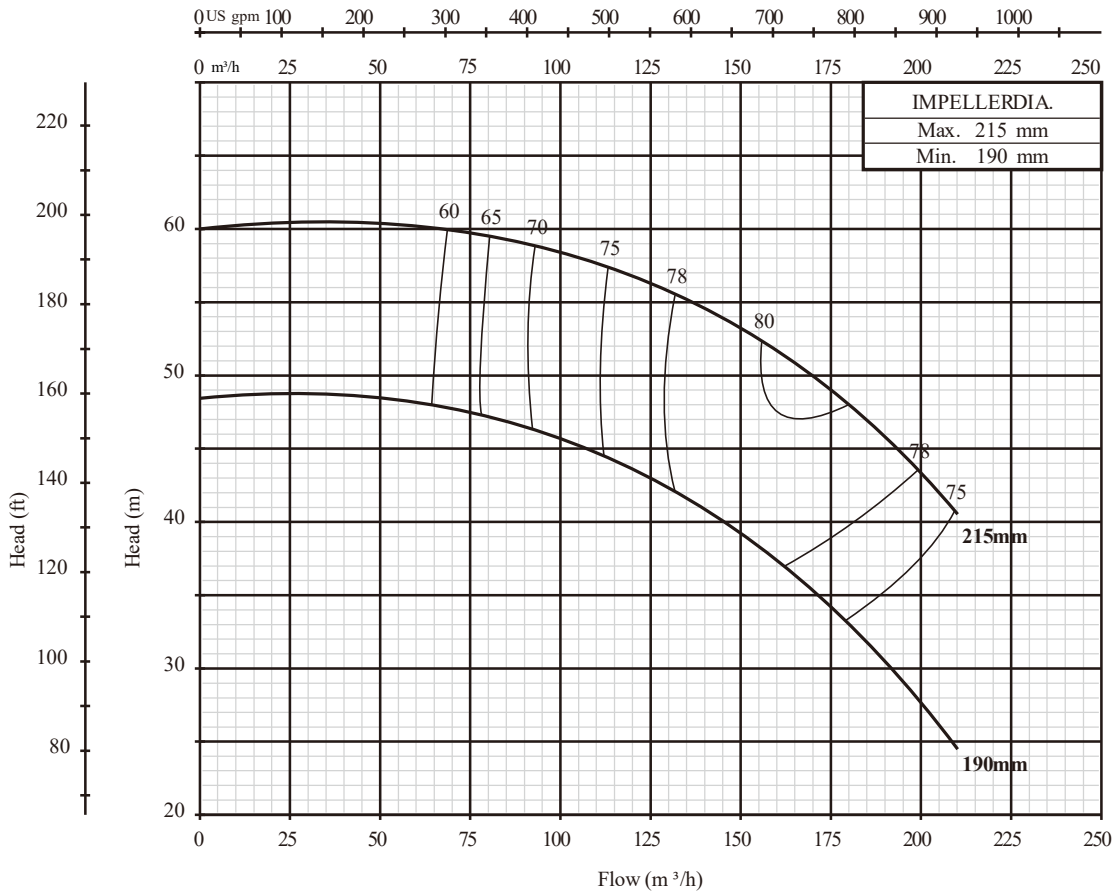

H - Q

P - Q

NPSHr

PERFORMANCE CURVE

80-250

2900rpm

PERFORMANCE CURVE

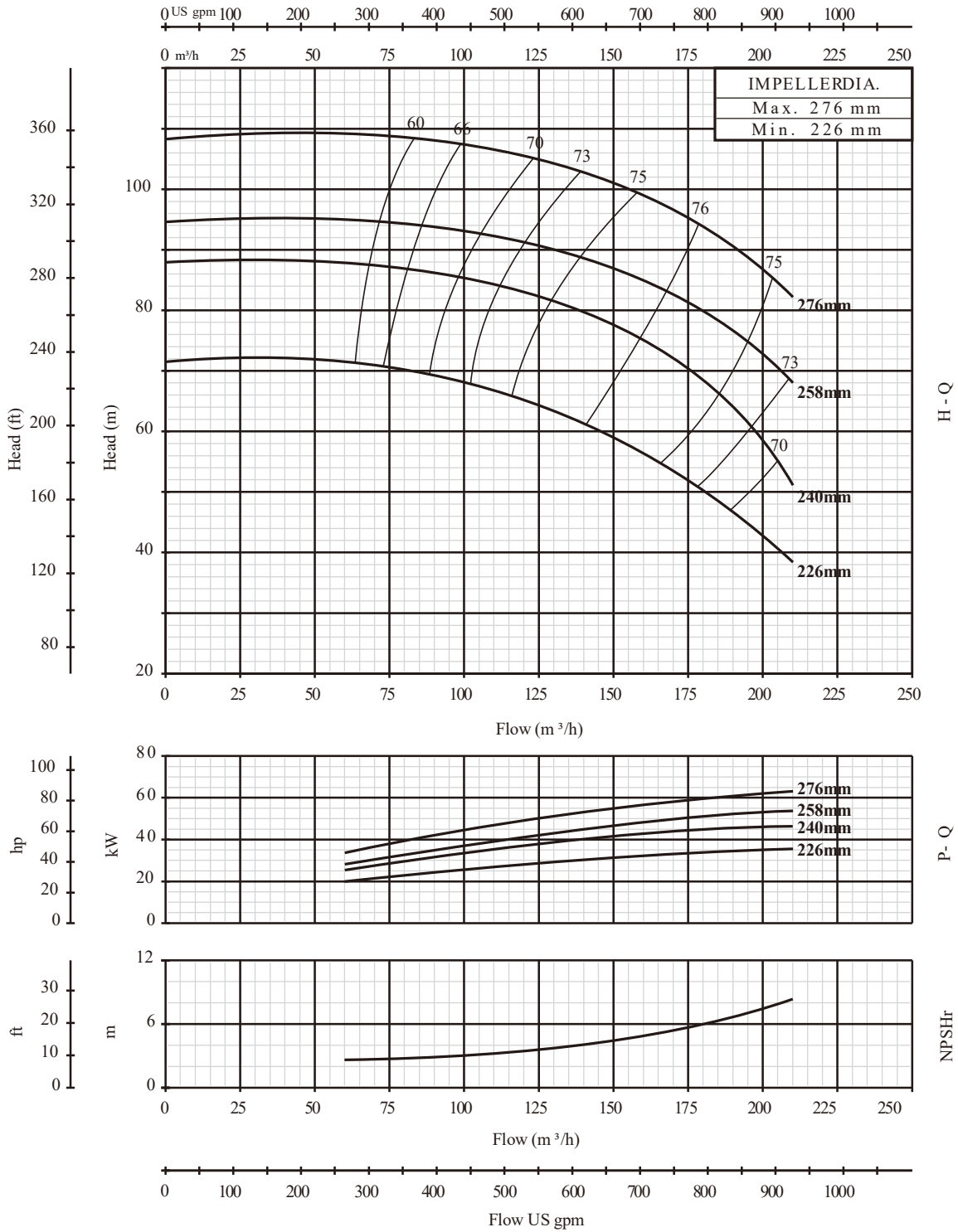

80-315

2900rpm

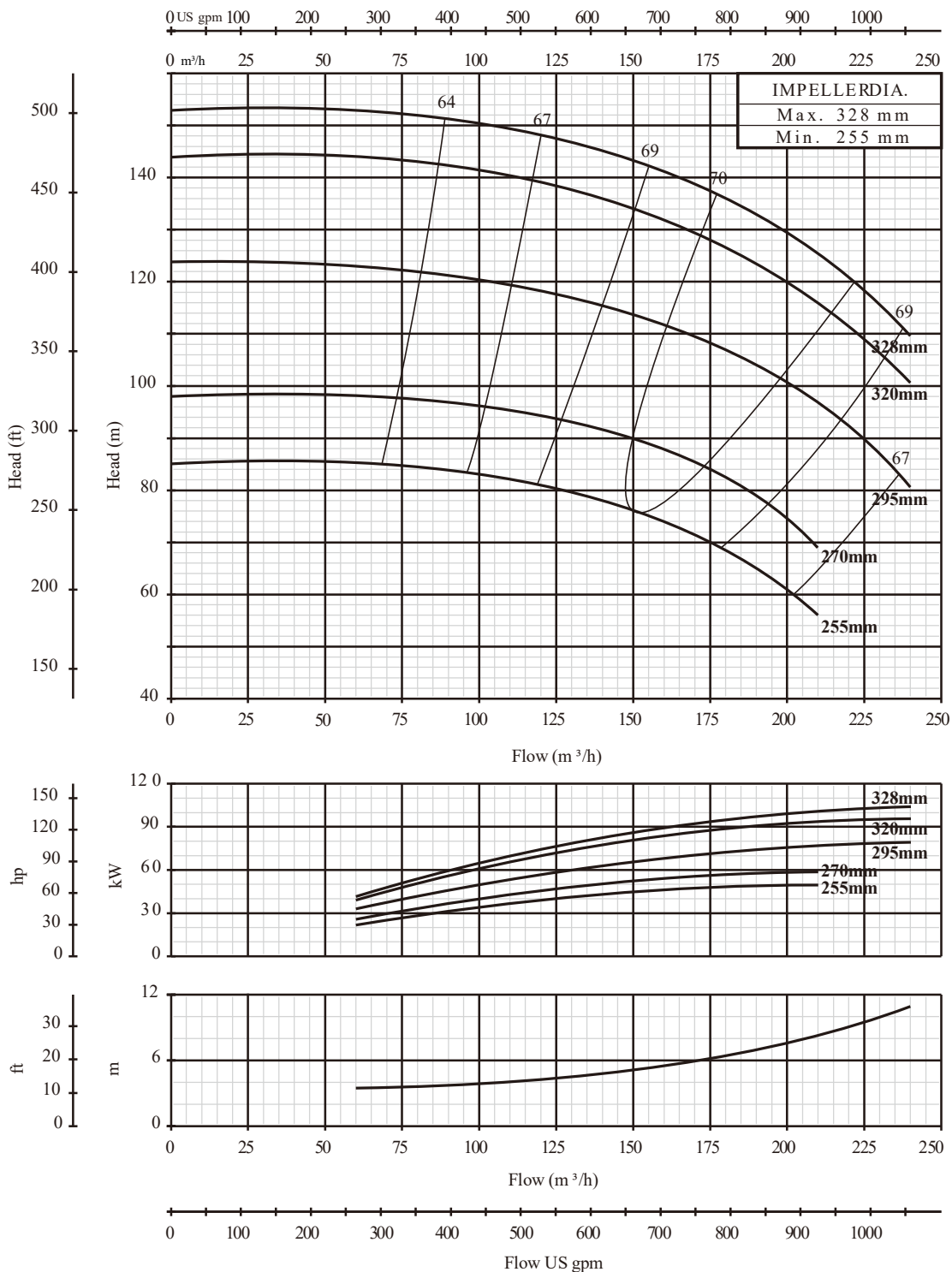

PERFORMANCE CURVE

100-160

2900rpm

PERFORMANCE CURVE

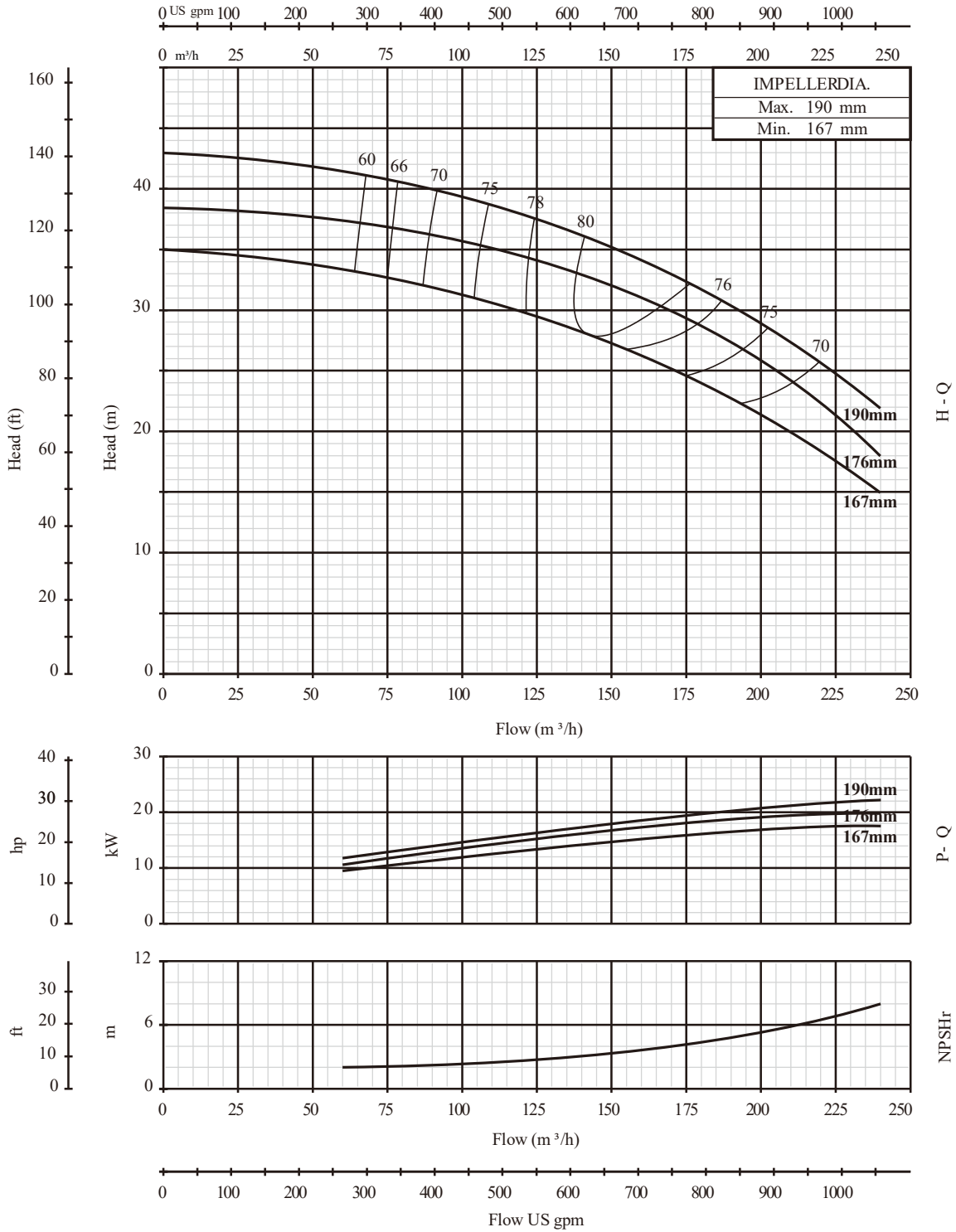

100-200

2900rpm

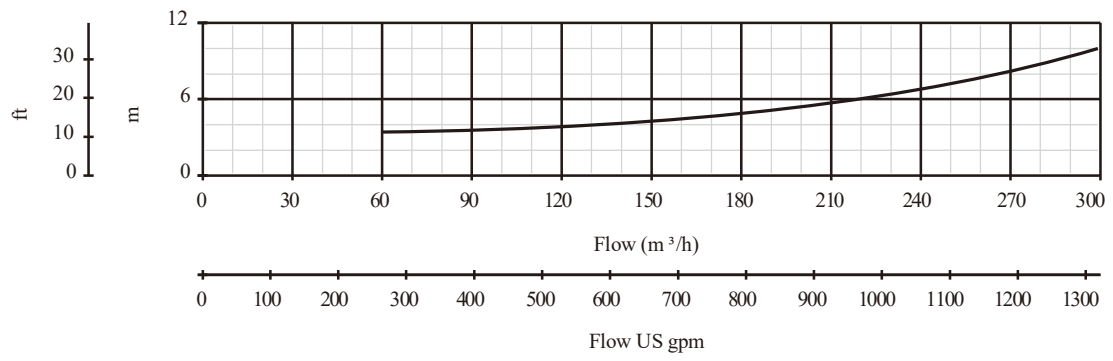
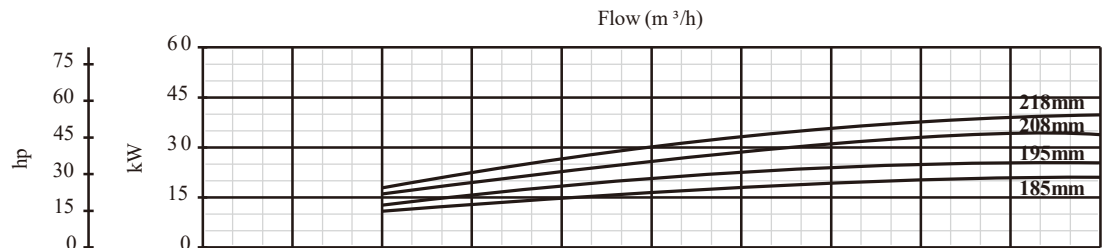
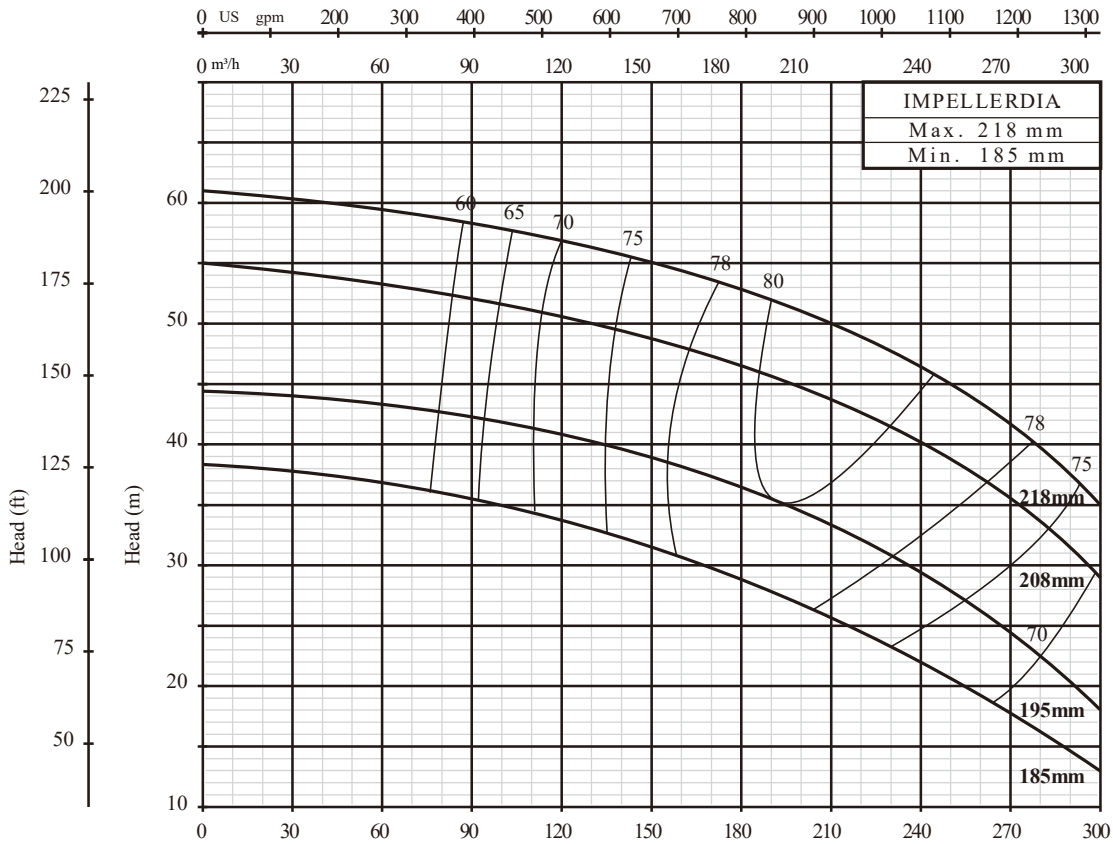

H - Q

P - Q

NPSHr

PERFORMANCE CURVE

100-250

2900rpm

PERFORMANCE CURVE

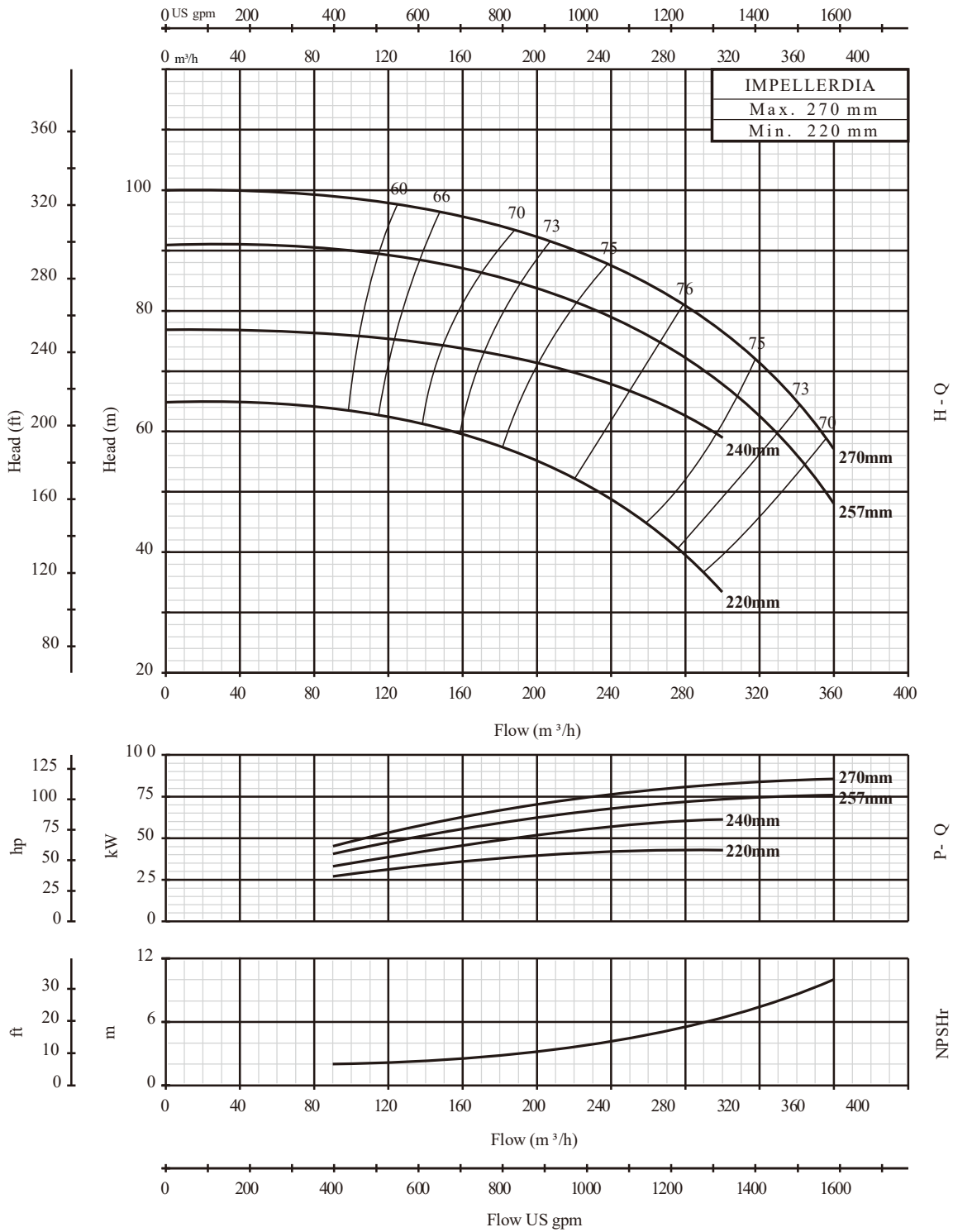

100-315

2900rpm

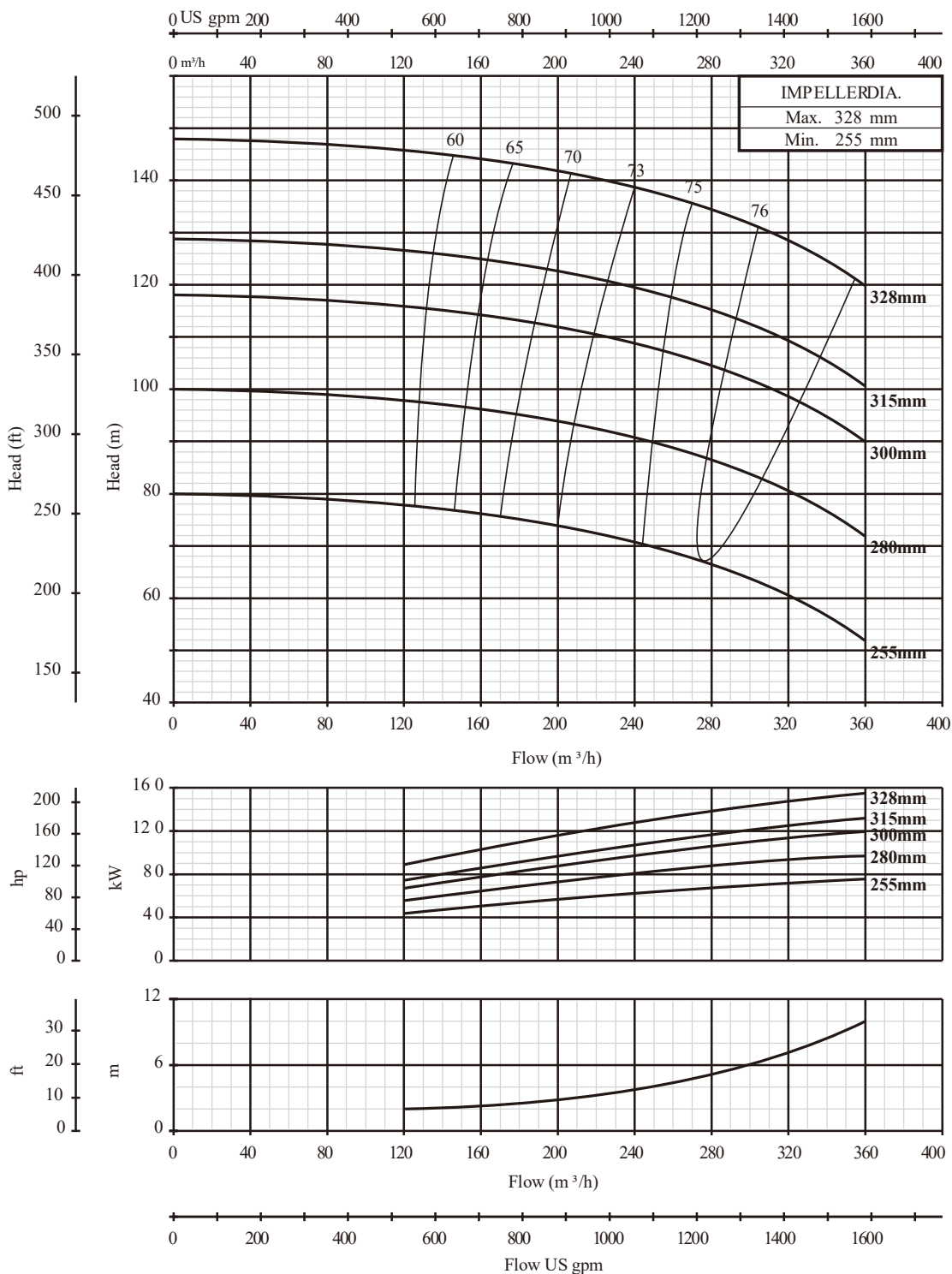

PERFORMANCE CURVE

125-200

2900rpm

PERFORMANCE CURVE

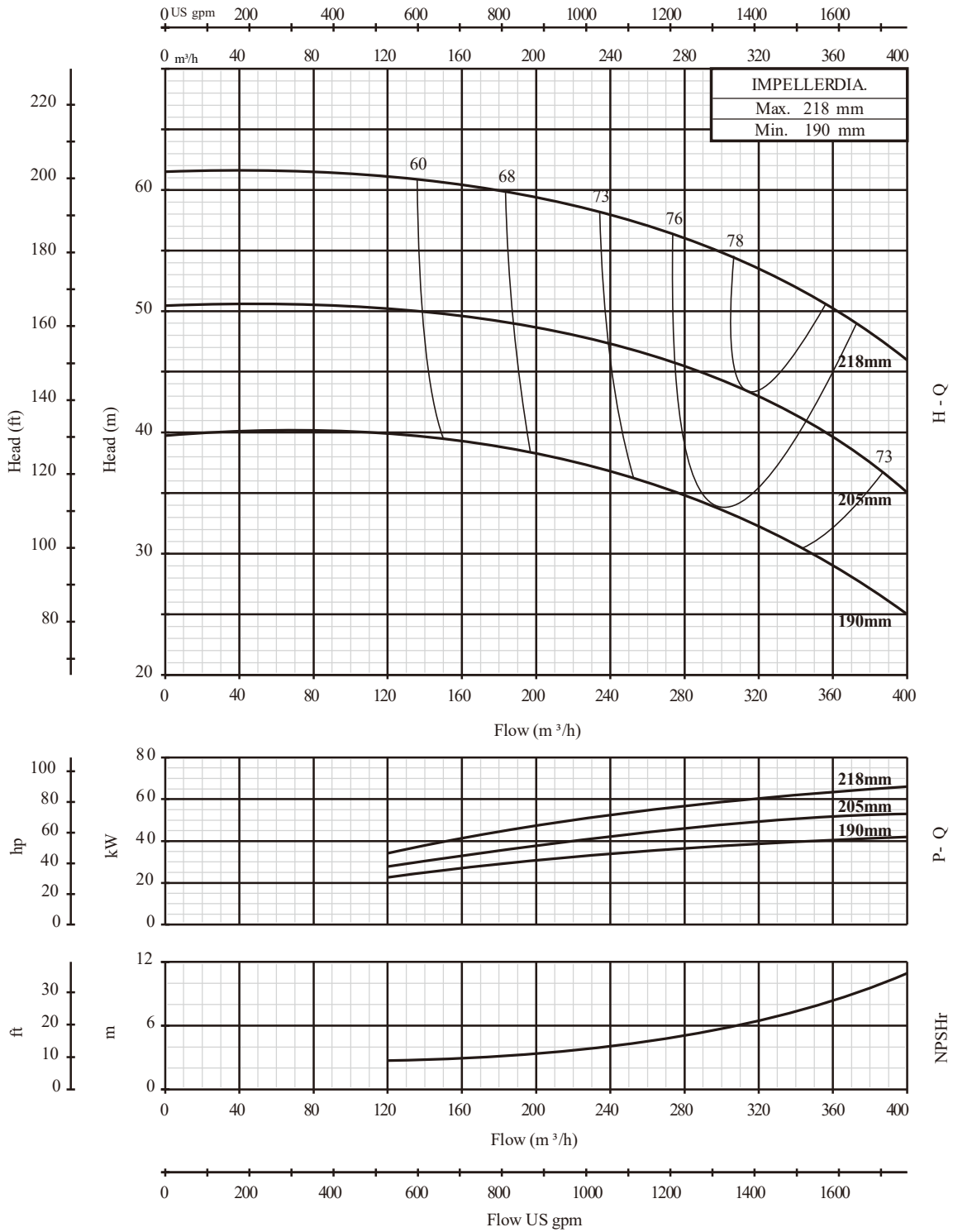

125-250

2900rpm

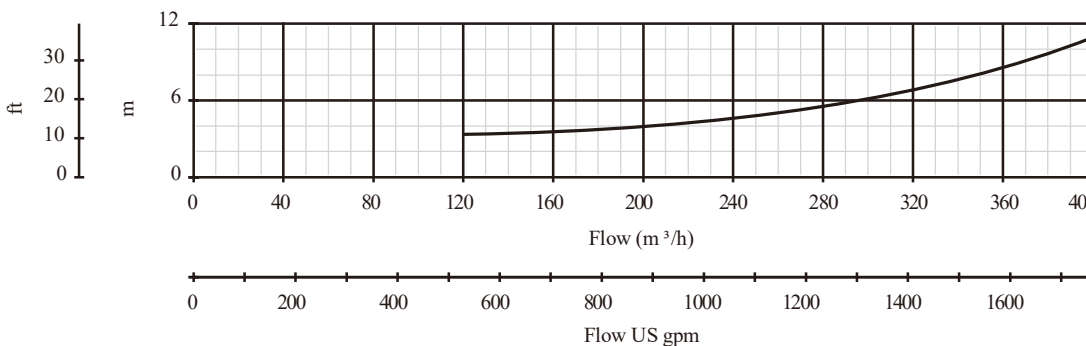
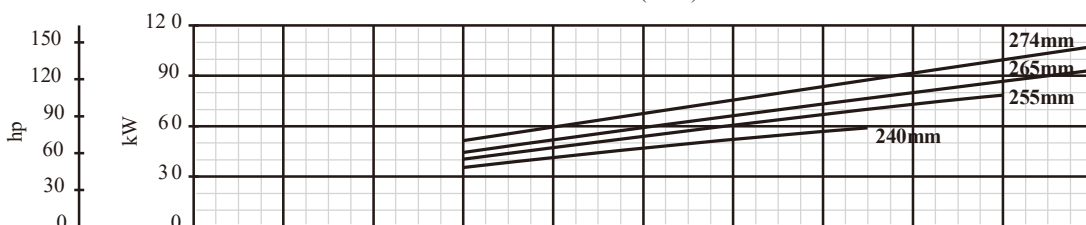
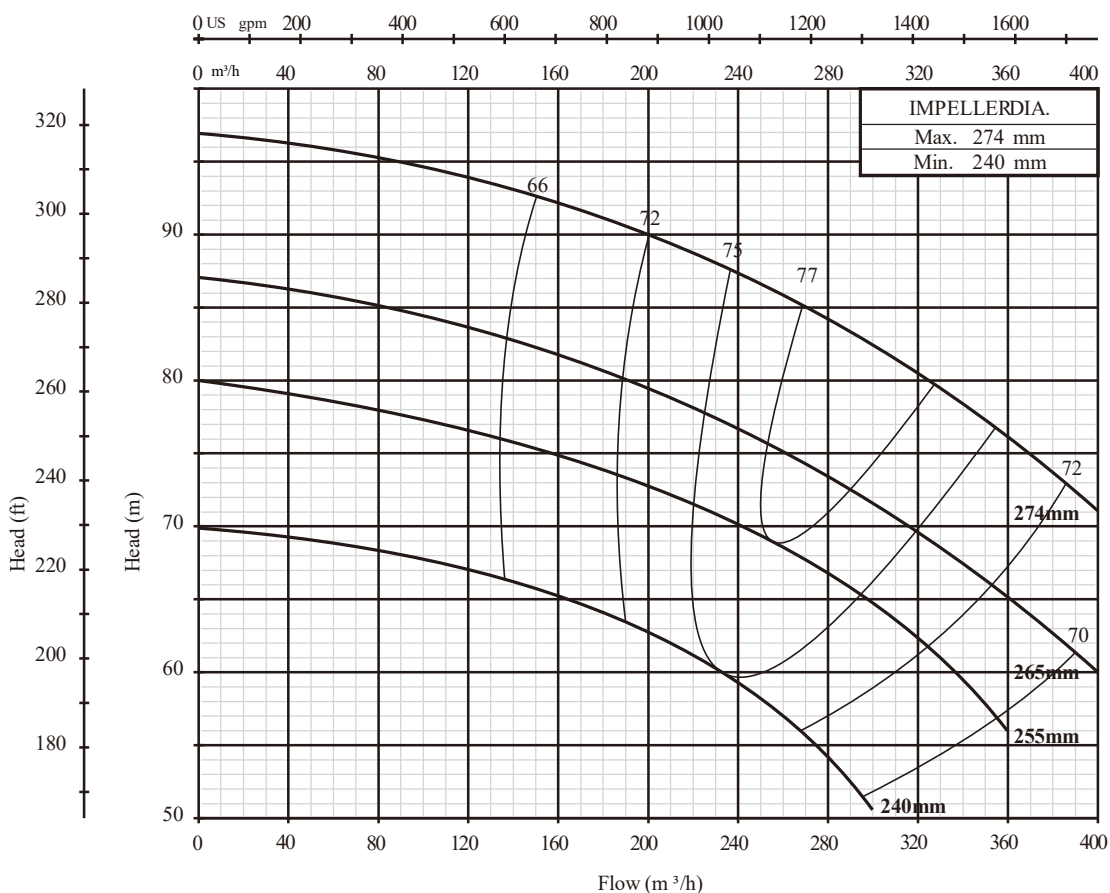

H - Q

P - Q

NPSHr

PERFORMANCE CURVE

125-250H

2900rpm

PERFORMANCE CURVE

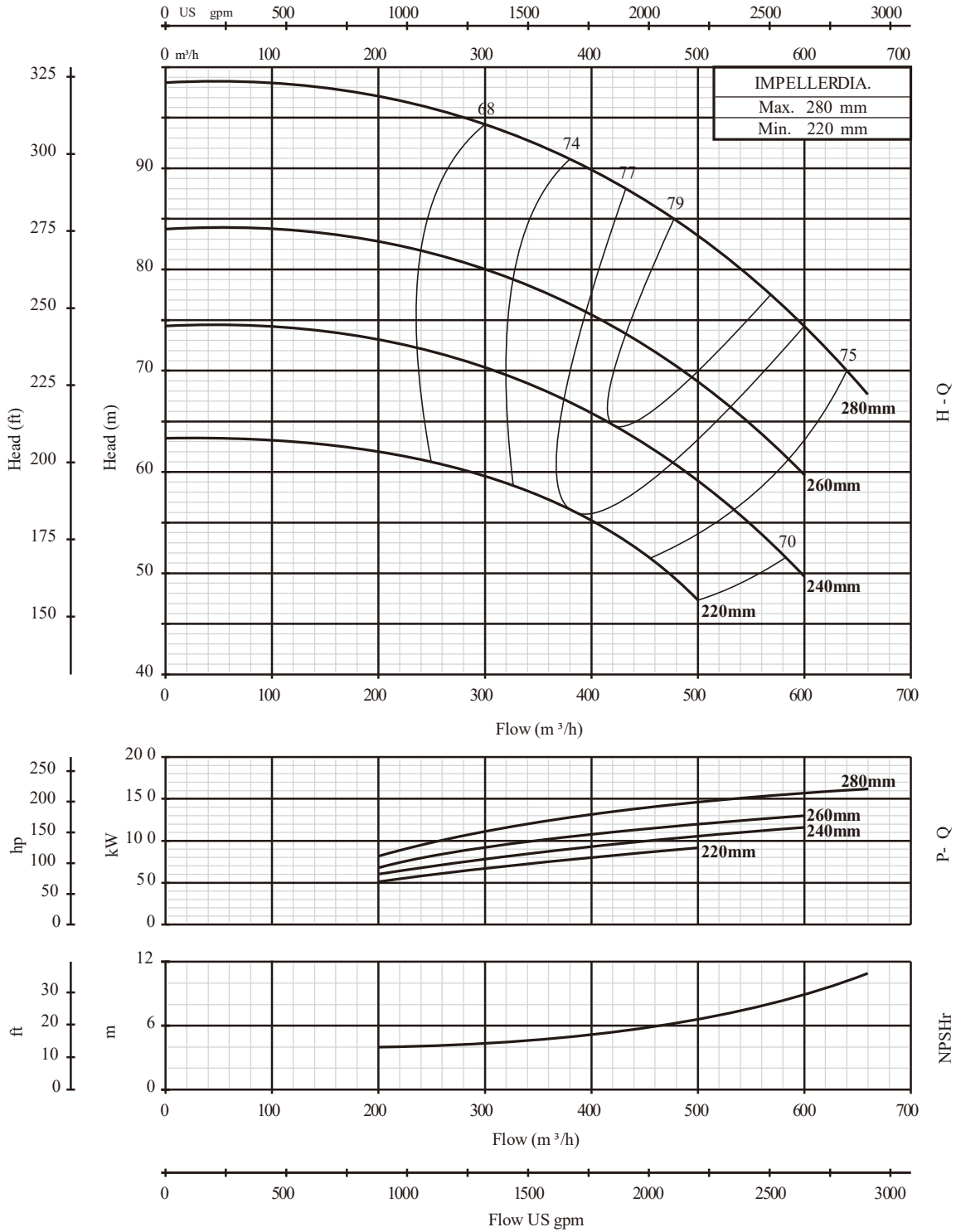

125-315

2900rpm

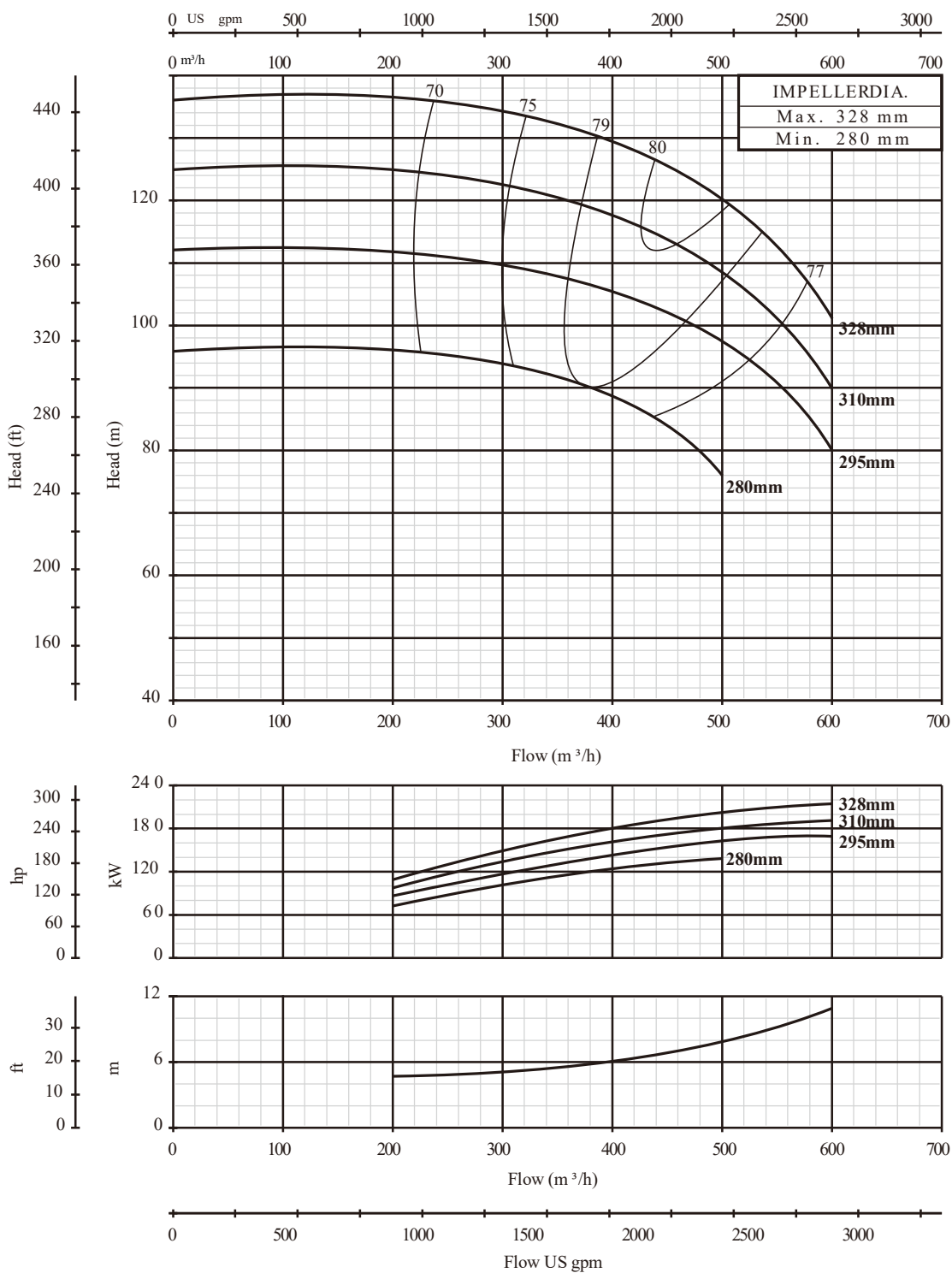

H - Q

P - Q

NPSHr

PERFORMANCE CURVE

150-200

2900rpm

PERFORMANCE CURVE

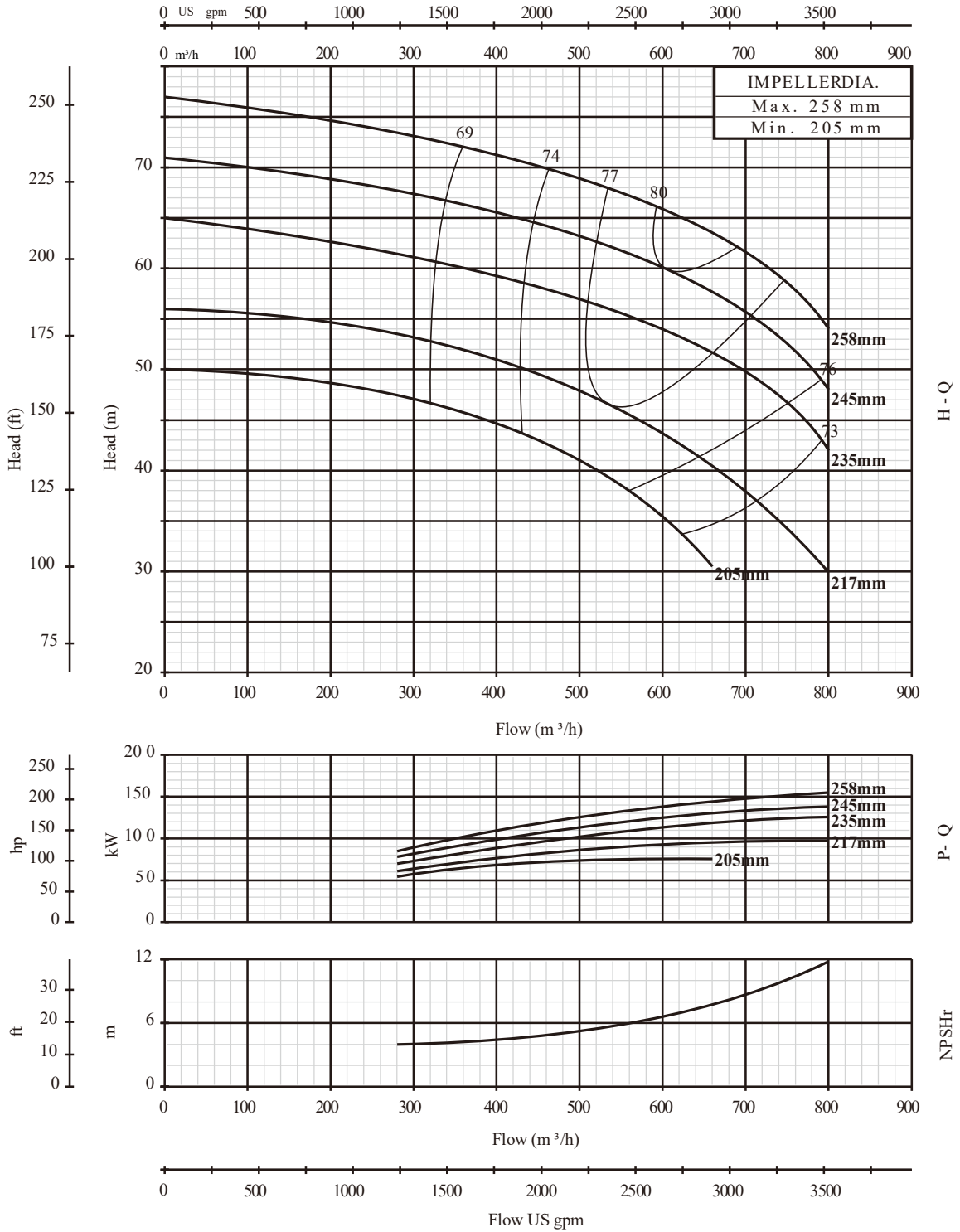

150-250

2900rpm

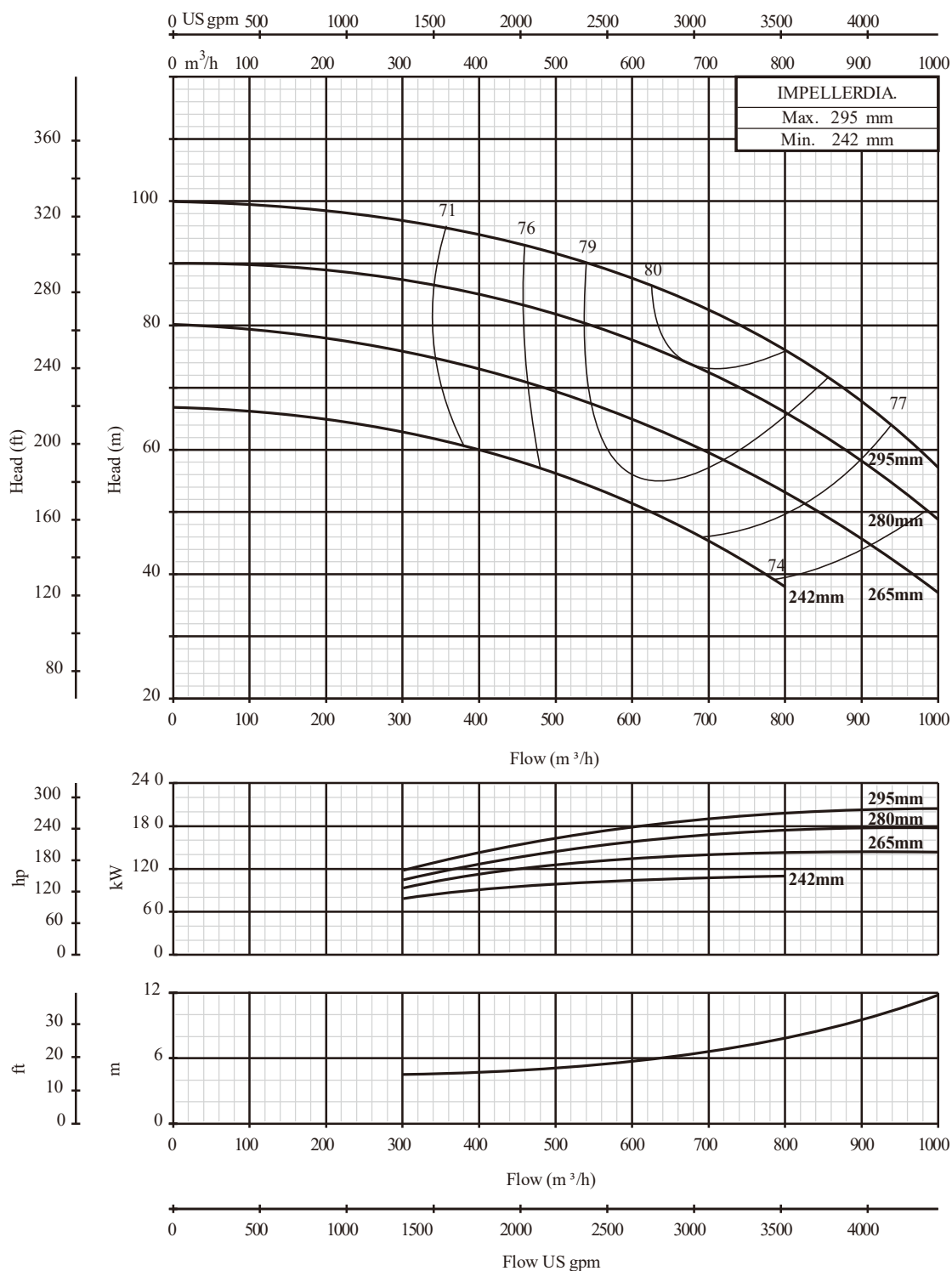

H - Q

P - Q

NPSHr

PERFORMANCE CURVE

150-315

2900rpm

PERFORMANCE CURVE

